

Metric series	Inch series	
With cage	Full-complement roller	
Hexagonal socket	Tapped hole	Slot for screwdriver
Without seal	With seal	
ミリ系	インチ系	
保持器付	総ころ	
六角穴	タップ穴	ドライバ溝
シールなし	シール付	

Miniature Cam Followers

ミニチュアカムフォロア

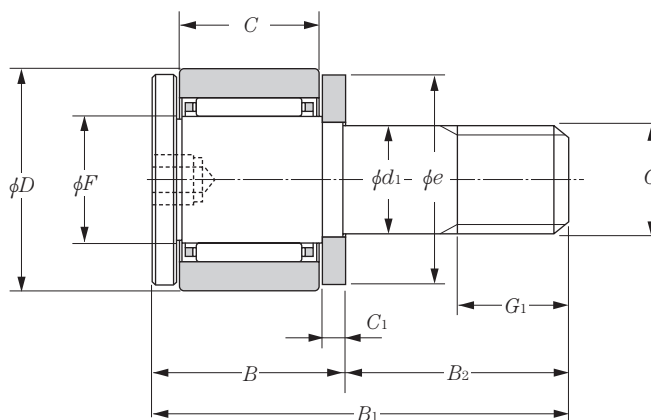
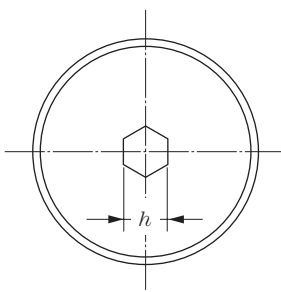

**KRM··XH type
(with cage)**
**KRMV··XH type
(Full-complement roller type)**

KRM··XH形 (保持器付)
KRMV··XH形 (総ころ形)

KRM··XH type (with cage)
KRM··XH形 (保持器付)

OD ¹⁾ 外径 mm D	Cam Follower number 呼び番号		Dimensions 寸法 mm										
	With cage 保持器付き	Full-complement roller 総ころ	d ₁	C	F	B	B ₁	B ₂	G	G ₁	C ₁	e	h
4	KRM4XT2H/3AS	—	1.5 ₀	2	1.8	3.5	6.5	3	M1.4×0.3	1.5	0.7	3.8	0.9
	—	KRMV4XH/3AS	1.5 ^{-0.006}	2	1.8	3.5	6.5	3	M1.4×0.3	1.5	0.7	3.8	0.9
4.5	KRM4.5XT2H/3AS	—	2 ₀	2.5	2.25	4	8	4	M2 ×0.4	2	0.7	4.3	0.9
	—	KRMV4.5XH/3AS	2 ^{-0.006}	2.5	2.25	4	8	4	M2 ×0.4	2	0.7	4.3	0.9
5	KRM5XT2H/3AS	—	2.5 ₀	3	2.7	4.5	9.5	5	M2.5×0.45	2.5	0.7	4.8	0.9
	—	KRMV5XH/3AS	2.5 ^{-0.006}	3	2.7	4.5	9.5	5	M2.5×0.45	2.5	0.7	4.8	0.9
6	KRM6XT2H/3AS	—	3 ₀	4	3.4	5.5	11.5	6	M3 ×0.5	3	0.7	5.8	1.3
	—	KRMV6XH/3AS	3 ^{-0.006}	4	3.4	5.5	11.5	6	M3 ×0.5	3	0.7	5.8	1.3
8	KRM8XT2H/3AS	—	4 ₀	5	4.5	7	15	8	M4 ×0.7	4	1	7.7	1.5
	—	KRMV8XH/3AS	4 ^{-0.008}	5	4.5	7	15	8	M4 ×0.7	4	1	7.7	1.5
10	KRM10XT2H/3AS	—	5 ₀	6	5.9	8	18	10	M5 ×0.8	5	1	9.6	2
	—	KRMV10XH/3AS	5 ^{-0.008}	6	5.9	8	18	10	M5 ×0.8	5	1	9.6	2
12	KRM12XT2H/3AS	—	6 ₀	7	6.7	9.5	21.5	12	M6 ×1	6	1.2	11.6	2.5
	—	KRMV12XH/3AS	6 ^{-0.008}	7	6.7	9.5	21.5	12	M6 ×1	6	1.2	11.6	2.5

Note: 1. JIS Class 0 is the dimensional tolerance.

注1) 許容差はJIS 0級である。

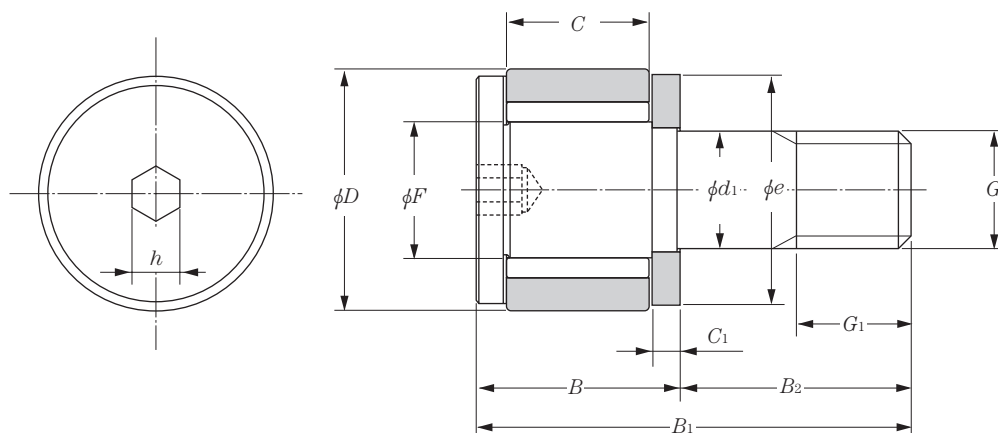

KRMV··XH type (Full-complement roller type)

KRMV··XH形 (総ころ形)

Basic load ratings		Track load capacity	Maximum tightening torque	Mass	Stud dia.
dynamic	static				
基本動 定格荷重	基本静 定格荷重	トラック負荷容量	締付最大トルク	質量	スタッド径
C_r	C_{or}	N kgf	N·m kgf·m	kg (approx.) (参考)	mm
222 23	138 14	147 15	0.1 0.01	0.0003 0.0004	1.5
505 51	480 49				
305 31	216 22	216 22	0.1 0.01	0.0005 0.0006	
695 71	765 78				2
445 45	370 37	294 30	0.3 0.03	0.0007 0.0009	
905 92	1 110 114				
645 66	630 63	480 49	0.5 0.05	0.0013 0.0014	3
1 280 130	1 840 187				
1 120 114	1 120 114	785 80	1 0.1	0.0029 0.0030	
2 120 216	3 050 310				4
1 570 160	1 860 189	1 190 121	2 0.2	0.0055 0.0059	
2 820 288	4 800 490				
2 160 220	2 300 237	1 640 167	3 0.3	0.0093 0.0080	6
4 150 425	6 450 655				

Metric series	Inch series	
With cage	Full-complement roller	
Hexagonal socket	Tapped hole	Slot for screwdriver
Without seal	With seal	
ミリ系	インチ系	
保持器付	総ころ	
六角穴	タップ穴	ドライバ溝
シールなし	シール付	

Cam Followers with Cage

保持器付カムフォロア

KR··H type
KR··XH type
KR··LLH type
KR··XLLH type

KR··H形
KR··XH形
KR··LLH形
KR··XLLH形

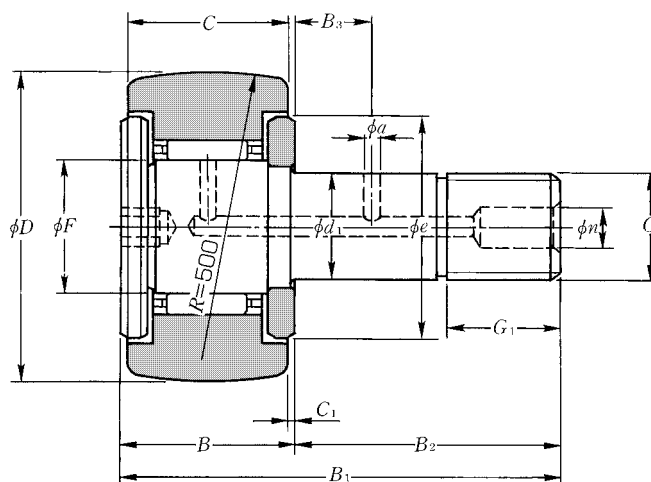
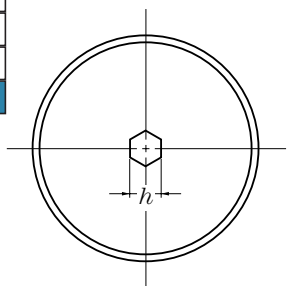

KR··H type (with cage)

KR··H形 (保持器付)

OD ¹⁾ 外径 mm D	Cam Follower number ²⁾ 呼び番号				Dimensions 寸法 mm						
	Without seal シールなし		With seal シール有り		d ₁	C	F	B	B ₁	B ₂	G
	Spherical outer rings 球面外輪	Cylindrical outer rings 円筒外輪	Spherical outer rings 球面外輪	Cylindrical outer rings 円筒外輪							
0 -0.05											
10	KR10T2H/3AS	KR10XT2H/3AS	KR10T2LLH/3AS	KR10XT2LLH/3AS	3 ⁰ _{-0.010}	7	4	8	17	9	M3×0.5
12	KR12T2H/3AS	KR12XT2H/3AS	KR12T2LLH/3AS	KR12XT2LLH/3AS	4 ⁰ _{-0.012}	8	4.8	9	20	11	M4×0.7
13	KR13T2H/3AS	KR13XT2H/3AS	KR13T2LLH/3AS	KR13XT2LLH/3AS	5 ⁰ _{-0.012}	9	5.75	10	23	13	M5×0.8
16	KR16H/3AS	KR16XH/3AS	KR16LLH/3AS	KR16XLLH/3AS	6 ⁰ _{-0.012}	11	8	12	28	16	M6×1
19	KR19H/3AS	KR19XH/3AS	KR19LLH/3AS	KR19XLLH/3AS	8 ⁰ _{-0.015}	11	10	12	32	20	M8×1.25
22	KR22H	KR22XH	KR22LLH/3AS	KR22XLLH/3AS	10 ⁰ _{-0.015}	12	12	13	36	23	M10×1.25
26	KR26H	KR26XH	KR26LLH/3AS	KR26XLLH/3AS	10 ⁰ _{-0.015}	12	12	13	36	23	M10×1.25
30	KR30H	KR30XH	KR30LLH/3AS	KR30XLLH/3AS	12 ⁰ _{-0.018}	14	15	15	40	25	M12×1.5
32	KR32H	KR32XH	KR32LLH/3AS	KR32XLLH/3AS	12 ⁰ _{-0.018}	14	15	15	40	25	M12×1.5
35	KR35H	KR35XH	KR35LLH/3AS	KR35XLLH/3AS	16 ⁰ _{-0.018}	18	18	19.5	52	32.5	M16×1.5
40	KR40H	KR40XH	KR40LLH/3AS	KR40XLLH/3AS	18 ⁰ _{-0.018}	20	22	21.5	58	36.5	M18×1.5
47	KR47H	KR47XH	KR47LLH/3AS	KR47XLLH/3AS	20 ⁰ _{-0.021}	24	25	25.5	66	40.5	M20×1.5
52	KR52H	KR52XH	KR52LLH/3AS	KR52XLLH/3AS	20 ⁰ _{-0.021}	24	25	25.5	66	40.5	M20×1.5
62	KR62H	KR62XH	KR62LLH/3AS	KR62XLLH/3AS	24 ⁰ _{-0.021}	29	30	30.5	80	49.5	M24×1.5
72	KR72H	KR72XH	KR72LLH/3AS	KR72XLLH/3AS	24 ⁰ _{-0.021}	29	30	30.5	80	49.5	M24×1.5
80	KR80H	KR80XH	KR80LLH/3AS	KR80XLLH/3AS	30 ⁰ _{-0.021}	35	38	37	100	63	M30×1.5
85	KR85H	KR85XH	KR85LLH/3AS	KR85XLLH/3AS	30 ⁰ _{-0.021}	35	38	37	100	63	M30×1.5
90	KR90H	KR90XH	KR90LLH/3AS	KR90XLLH/3AS	30 ⁰ _{-0.021}	35	38	37	100	63	M30×1.5

Notes: 1. JIS Class 0 is the dimensional tolerance of the outside diameter *D* of the outer rings of the KR··XH and KR··XLLH types whose outside surface form is cylindrical.
2. A bearing number with a T2 suffix indicates a bearing with a resin cage. Its maximum allowable temperature is 120°C and continuous operation temperature is 100°C.

注1) 外径面が円筒であるKR··XH形、KR··XLLH形の外輪外径*D*の許容差はJIS 0級である。

2) 呼び番号の後にT2の付く軸受は、樹脂保持器付きであり、許容温度は120°C、連続使用では100°C以下とする。

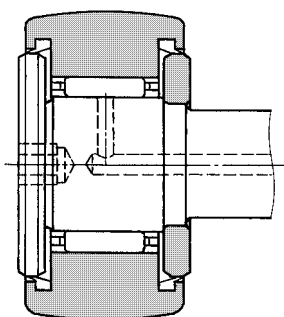

KR·LLH type (with cage, sealed)

KR·LLH形 (保持器付シール形)

Accessories / 付属部品

Applicable bearing number 適用軸受 呼び番号	Grease nipple number グリースニップル 呼び番号	Plug number プラグ 呼び番号	Applicable hexagonal nut 適用六角ナット
10~19	—	—	1M3×0.5~1M8×1.25
22~26	NIP-B4	SEN4	1M10×1.25
30~40	NIP-B6	SEN6	1M12×1.5~1M18×1.5
47~90	NIP-B8	SEN8	1M20×1.5~1M30×1.5

Note: The boundary dimensions of grease nipples and plugs are listed in **Table 3** on page 9 and **Table 5** on page 10.

*グリースニップル及びプラグの主要寸法は9ページ表3, 10ページ表5に示す。



NIP-B6

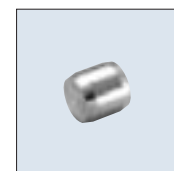

SEN6



1M12

Dimensions 寸法 mm							Basic load ratings 基本動 N 基本静 定格荷重 kgf 定格荷重		Track load capacity トラック負荷容量 N		Limiting speed 許容回転速度 r/min		Maximum tightening torque 締付最大トルク N·m kgf·m	Mass 質量 kg (approx.) (参考)	Stud dia. スタッド径 mm
G ₁	B ₃	C ₁	n	a	e	h	C _r	C _{or}	Spherical outer ring 球面外輪	Cylindrical outer ring 円筒外輪	Grease lubrication グリース潤滑	Oil lubrication 油潤滑			
5	—	0.5	—	—	7	2.5	1 640 168	1 270 130	560 57	1 360 139	*27 000	*40 000	0.5 0.05	0.005	3
6	—	0.5	—	—	8.5	2.5	2 170 221	1 690 172	725 74	1 790 183	*25 000	*36 000	1 0.1	0.008	4
7.5	—	0.5	—	—	9.5	3	2 650 270	2 260 231	805 82	2 220 226	*23 000	*33 000	2 0.2	0.010	5
8	—	0.6	—	—	12	3	4 050 415	4 200 430	1 080 110	3 400 350	*19 000	*25 000	3 0.3	0.019	6
10	—	0.6	—	—	14	4	4 750 480	5 400 555	1 380 141	4 050 415	*15 000	*20 000	8 0.8	0.031	8
12	—	0.6	4	—	17	4	5 300 540	6 650 680	1 690 172	5 150 525	*12 000	*16 000	14 1.4	0.046	10
12	—	0.6	4	—	17	4	5 300 540	6 650 680	2 120 216	6 100 620	*12 000	*16 000	14 1.4	0.059	10
13	6	0.6	6	3	23	6	7 850 800	9 650 985	2 620 267	7 700 785	10 000	*13 000	20 2	0.087	12
13	6	0.6	6	3	23	6	7 850 800	9 650 985	2 860 291	8 200 835	10 000	*13 000	20 2	0.097	12
17	8	0.8	6	3	27	6	12 200 1 240	17 900 1 830	3 200 325	11 900 1 220	8 000	*11 000	52 5.3	0.169	16
19	8	0.8	6	3	32	6	14 000 1 430	22 800 2 330	3 850 390	14 500 1 480	7 000	9 000	76 7.8	0.248	18
21	9	0.8	8	4	37	8	20 700 2 110	33 500 3 450	4 700 480	21 000 2 150	6 000	8 000	98 10	0.386	20
21	9	0.8	8	4	37	8	20 700 2 110	33 500 3 450	5 550 565	23 300 2 370	6 000	8 000	98 10	0.461	20
25	11	0.8	8	4	44	8	28 900 2 950	55 000 5 600	6 950 710	34 500 3 500	5 000	6 500	178 18	0.790	24
25	11	0.8	8	4	44	8	28 900 2 950	55 000 5 600	8 050 820	38 500 3 900	5 000	6 500	178 18	1.04	24
32	15	1	8	4	53	8	45 000 4 600	88 500 9 050	9 800 1 000	53 000 5 400	4 000	5 500	360 37	1.55	30
32	15	1	8	4	53	8	45 000 4 600	88 500 9 050	10 400 1 060	56 000 5 750	4 000	5 500	360 37	1.74	30
32	15	1	8	4	53	8	45 000 4 600	88 500 9 050	11 400 1 160	59 000 6 100	4 000	5 500	360 37	1.95	30

Note: The limiting speed of KR·LLH and KR·XLLH types incorporating a seal (those marked with an asterisk) is approximately 10,000 rpm.

備考 ※印シール有りKR·LLH形, KR·XLLH形の許容回転速度はおおよそ10 000 r/minである。

Metric series	Inch series	
With cage	Full-complement roller	
Hexagonal socket	Tapped hole	Slot for screwdriver
Without seal	With seal	
ミリ系	インチ系	
保持器付	総ころ	
六角穴	タップ穴	ドライバ溝
シールなし	シール付	

Cam Followers with Cage

保持器付カムフォロア

KR type
KR··X type
KR··LL type
KR··XLL type

KR形
KR··X形
KR··LL形
KR··XLL形

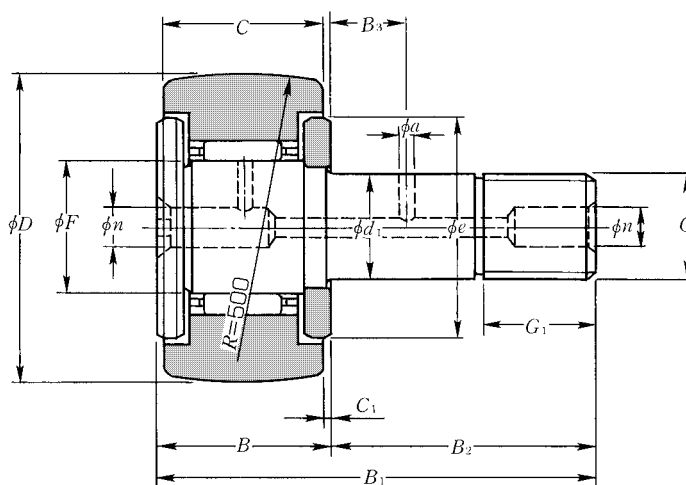
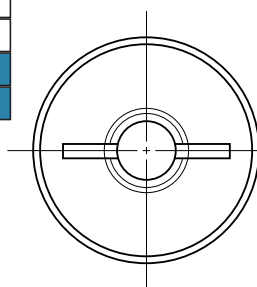

KR type (with cage)
KR形 (保持器付)

OD ¹⁾ 外径 mm D	Cam Follower number 呼び番号				Dimensions 寸法 mm						
	Without seal シールなし		With seal シール有り		d ₁	C	F	B	B ₁	B ₂	G
	Spherical outer rings 球面外輪	Cylindrical outer rings 円筒外輪	Spherical outer rings 球面外輪	Cylindrical outer rings 円筒外輪							
0 -0.05											
16	KR16	KR16X	KR16LL/3AS	KR16XLL/3AS	6 ⁰ _{-0.012}	11	8	12	28	16	M6×1
19	KR19	KR19X	KR19LL/3AS	KR19XLL/3AS	8 ⁰ _{-0.015}	11	10	12	32	20	M8×1.25
22	KR22	KR22X	KR22LL/3AS	KR22XLL/3AS	10 ⁰ _{-0.015}	12	12	13	36	23	M10×1.25
26	KR26	KR26X	KR26LL/3AS	KR26XLL/3AS	10 ⁰ _{-0.015}	12	12	13	36	23	M10×1.25
30	KR30	KR30X	KR30LL/3AS	KR30XLL/3AS	12 ⁰ _{-0.018}	14	15	15	40	25	M12×1.5
32	KR32	KR32X	KR32LL/3AS	KR32XLL/3AS	12 ⁰ _{-0.018}	14	15	15	40	25	M12×1.5
35	KR35	KR35X	KR35LL/3AS	KR35XLL/3AS	16 ⁰ _{-0.018}	18	18	19.5	52	32.5	M16×1.5
40	KR40	KR40X	KR40LL/3AS	KR40XLL/3AS	18 ⁰ _{-0.018}	20	22	21.5	58	36.5	M18×1.5
47	KR47	KR47X	KR47LL/3AS	KR47XLL/3AS	20 ⁰ _{-0.021}	24	25	25.5	66	40.5	M20×1.5
52	KR52	KR52X	KR52LL/3AS	KR52XLL/3AS	20 ⁰ _{-0.021}	24	25	25.5	66	40.5	M20×1.5
62	KR62	KR62X	KR62LL/3AS	KR62XLL/3AS	24 ⁰ _{-0.021}	29	30	30.5	80	49.5	M24×1.5
72	KR72	KR72X	KR72LL/3AS	KR72XLL/3AS	24 ⁰ _{-0.021}	29	30	30.5	80	49.5	M24×1.5
80	KR80	KR80X	KR80LL/3AS	KR80XLL/3AS	30 ⁰ _{-0.021}	35	38	37	100	63	M30×1.5
85	KR85	KR85X	KR85LL/3AS	KR85XLL/3AS	30 ⁰ _{-0.021}	35	38	37	100	63	M30×1.5
90	KR90	KR90X	KR90LL/3AS	KR90XLL/3AS	30 ⁰ _{-0.021}	35	38	37	100	63	M30×1.5

Notes: 1. JIS Class 0 is the dimensional tolerance of the outside diameter D of the outer rings of the KR··X and KR··XLL types whose outside surface form is cylindrical.
2. The grease replenishment port is situated only in the front (in the left side face in the diagram above).
注1) 外径面が円筒であるKR··X形、KR··XLL形の外輪外径Dの許容差はJIS 0級である。
注2) グリースの補給穴は正面(上図左側面)にだけ設けている。

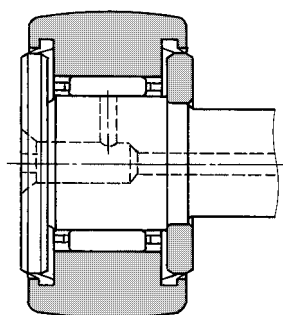

KR·LL type (with cage, sealed)
KR·LL形 (保持器付シール形)

Accessories / 付属部品

Applicable bearing number 適用軸受 呼び番号	Grease nipple number グリースニップル 呼び番号	Plug number プラグ 呼び番号	Applicable hexagonal nut 適用六角ナット
16~26	NIP-B4	SEN4	1M 6×1 ~1M10×1.25
30~40	NIP-B6	SEN6	1M12×1.5~1M18×1.5
47~90	NIP-B8	SEN8	1M20×1.5~1M30×1.5

Note: The boundary dimensions of grease nipples and plugs are listed in Table 3 on page 9 and Table 5 on page 10.

*グリースニップル及びプラグの主要寸法は9ページ表3、10ページ表5に示す。

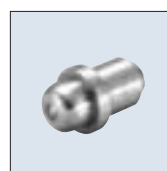

NIP-B6

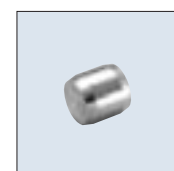

SEN6

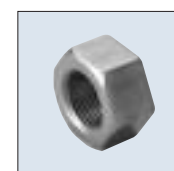

1M12

Dimensions 寸法 mm						Basic load ratings 基本動 N 基本静 定格荷重 kgf 定格荷重		Track load capacity トラック負荷容量 N		Limiting speed 許容回転速度 r/min		Maximum tightening torque 締付最大トルク N·m kgf·m	Mass 質量 kg (approx.) (参考)	Stud dia. スタッド径 mm
G_1	B_3	C_1	n	a	e	C_r	C_{or}	Spherical outer ring 球面外輪	Cylindrical outer ring 円筒外輪	Grease lubrication グリース潤滑	Oil lubrication 油潤滑			
8	—	0.6	4 ²⁾	—	12	4 050 415	4 200 430	1 080 110	3 400 350	*19 000	*25 000	3 0.3	0.019	6
10	—	0.6	4 ²⁾	—	14	4 750 480	5 400 555	1 380 141	4 050 415	*15 000	*20 000	8 0.8	0.031	8
12	—	0.6	4	—	17	5 300 540	6 650 680	1 690 172	5 150 525	*12 000	*16 000	14 1.4	0.046	10
12	—	0.6	4	—	17	5 300 540	6 650 680	2 120 216	6 100 620	*12 000	*16 000	14 1.4	0.059	10
13	6	0.6	6	3	23	7 850 800	9 650 985	2 620 267	7 700 785	10 000	*13 000	20 2	0.087	12
13	6	0.6	6	3	23	7 850 800	9 650 985	2 860 291	8 200 835	10 000	*13 000	20 2	0.097	12
17	8	0.8	6	3	27	12 200 1 240	17 900 1 830	3 200 325	11 900 1 220	8 000	*11 000	52 5.3	0.169	16
19	8	0.8	6	3	32	14 000 1 430	22 800 2 330	3 850 390	14 500 1 480	7 000	9 000	76 7.8	0.248	18
21	9	0.8	8	4	37	20 700 2 110	33 500 3 450	4 700 480	21 000 2 150	6 000	8 000	98 10	0.386	20
21	9	0.8	8	4	37	20 700 2 110	33 500 3 450	5 550 565	23 300 2 370	6 000	8 000	98 10	0.461	20
25	11	0.8	8	4	44	28 900 2 950	55 000 5 600	6 950 710	34 500 3 500	5 000	6 500	178 18	0.790	24
25	11	0.8	8	4	44	28 900 2 950	55 000 5 600	8 050 820	38 500 3 900	5 000	6 500	178 18	1.04	24
32	15	1	8	4	53	45 000 4 600	88 500 9 050	9 800 1 000	53 000 5 400	4 000	5 500	360 37	1.55	30
32	15	1	8	4	53	45 000 4 600	88 500 9 050	10 400 1 060	56 000 5 750	4 000	5 500	360 37	1.74	30
32	15	1	8	4	53	45 000 4 600	88 500 9 050	11 400 1 160	59 000 6 100	4 000	5 500	360 37	1.95	30

Note: The limiting speed of KR·LL and KR·XLL types incorporating a seal (those marked with an asterisk) is approximately 10,000 rpm.

備考 *印シール有りKR·LL形、KR·XLL形の許容回転速度はおおよそ10 000r/minである。

Metric series	Inch series	
With cage	Full-complement roller	
Hexagonal socket	Tapped hole	Slot for screwdriver
Without seal	With seal	
ミリ系	インチ系	
保持器付	総ころ	
六角穴	タップ穴	ドライバ溝
シールなし	シール付	

Full-Complement Roller-Type Cam Followers

総ころ形カムフォロア

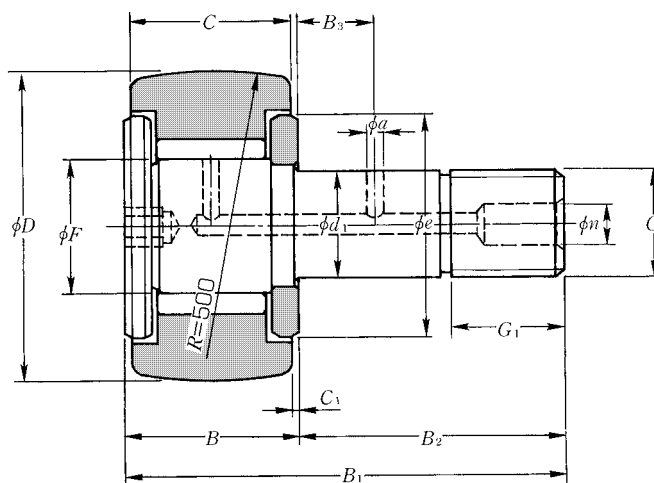
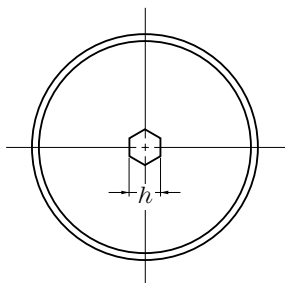

KRV··H type
KRV··XH type
KRV··LLH type
KRV··XLLH type

KRV··H形
KRV··XH形
KRV··LLH形
KRV··XLLH形

KRV··H type (Full-complement roller type)

KRV··H形 (総ころ形)

OD ¹⁾ 外径 mm D	Cam Follower number 呼び番号				Dimensions 寸法 mm						
	Without seal シールなし		With seal シール有り		d ₁	C	F	B	B ₁	B ₂	G
	Spherical outer rings 球面外輪	Cylindrical outer rings 円筒外輪	Spherical outer rings 球面外輪	Cylindrical outer rings 円筒外輪							
0 -0.05											
10	KRV10H/3AS	KRV10XH/3AS	KRV10LLH/3AS	KRV10XLLH/3AS	3 ⁰ _{-0.010}	7	4	8	17	9	M3×0.5
12	KRV12H/3AS	KRV12XH/3AS	KRV12LLH/3AS	KRV12XLLH/3AS	4 ⁰ _{-0.012}	8	4.8	9	20	11	M4×0.7
13	KRV13H/3AS	KRV13XH/3AS	KRV13LLH/3AS	KRV13XLLH/3AS	5 ⁰ _{-0.012}	9	5.75	10	23	13	M5×0.8
16	KRV16H/3AS	KRV16XH/3AS	KRV16LLH/3AS	KRV16XLLH/3AS	6 ⁰ _{-0.012}	11	8	12	28	16	M6×1
19	KRV19H/3AS	KRV19XH/3AS	KRV19LLH/3AS	KRV19XLLH/3AS	8 ⁰ _{-0.015}	11	10	12	32	20	M8×1.25
22	KRV22H/3AS	KRV22XH/3AS	KRV22LLH/3AS	KRV22XLLH/3AS	10 ⁰ _{-0.015}	12	12	13	36	23	M10×1.25
26	KRV26H/3AS	KRV26XH/3AS	KRV26LLH/3AS	KRV26XLLH/3AS	10 ⁰ _{-0.015}	12	12	13	36	23	M10×1.25
30	KRV30H/3AS	KRV30XH/3AS	KRV30LLH/3AS	KRV30XLLH/3AS	12 ⁰ _{-0.018}	14	15	15	40	25	M12×1.5
32	KRV32H/3AS	KRV32XH/3AS	KRV32LLH/3AS	KRV32XLLH/3AS	12 ⁰ _{-0.018}	14	15	15	40	25	M12×1.5
35	KRV35H/3AS	KRV35XH/3AS	KRV35LLH/3AS	KRV35XLLH/3AS	16 ⁰ _{-0.018}	18	18	19.5	52	32.5	M16×1.5
40	KRV40H/3AS	KRV40XH/3AS	KRV40LLH/3AS	KRV40XLLH/3AS	18 ⁰ _{-0.018}	20	22	21.5	58	36.5	M18×1.5
47	KRV47H/3AS	KRV47XH/3AS	KRV47LLH/3AS	KRV47XLLH/3AS	20 ⁰ _{-0.021}	24	25	25.5	66	40.5	M20×1.5
52	KRV52H/3AS	KRV52XH/3AS	KRV52LLH/3AS	KRV52XLLH/3AS	20 ⁰ _{-0.021}	24	25	25.5	66	40.5	M20×1.5
62	KRV62H/3AS	KRV62XH/3AS	KRV62LLH/3AS	KRV62XLLH/3AS	24 ⁰ _{-0.021}	29	30	30.5	80	49.5	M24×1.5
72	KRV72H/3AS	KRV72XH/3AS	KRV72LLH/3AS	KRV72XLLH/3AS	24 ⁰ _{-0.021}	29	30	30.5	80	49.5	M24×1.5
80	KRV80H/3AS	KRV80XH/3AS	KRV80LLH/3AS	KRV80XLLH/3AS	30 ⁰ _{-0.021}	35	38	37	100	63	M30×1.5
90	KRV90H/3AS	KRV90XH/3AS	KRV90LLH/3AS	KRV90XLLH/3AS	30 ⁰ _{-0.021}	35	38	37	100	63	M30×1.5

Note: 1. JIS Class 0 is the dimensional tolerance of the outside diameter D of the outer rings of the KRV··XH and KRV··XLLH types whose outside surface form is cylindrical.
注1) 外径面が円筒であるKRV··XH形、KRV··XLLH形の外輪外径Dの許容差はJIS 0級である。

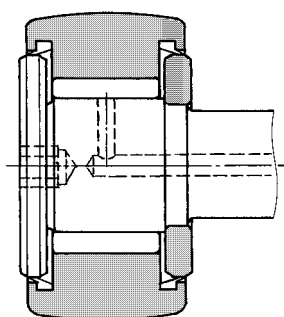

KRV·LLH type
(Full-complement roller type, with seal)
 KRV·LLH形 (総ころシール形)

Accessories / 付属部品

Applicable bearing number 適用軸受 呼び番号	Grease nipple number グリースニップル 呼び番号	Plug number プラグ 呼び番号	Applicable hexagonal nut 適用六角ナット
10~19	—	—	1M3×0.5~1M8×1.25
22~26	NIP-B4	SEN4	1M10×1.25
30~40	NIP-B6	SEN6	1M12×1.5~1M18×1.5
47~90	NIP-B8	SEN8	1M20×1.5~1M30×1.5

Note: The boundary dimensions of grease nipples and plugs are listed in **Table 3** on page 9 and **Table 5** on page 10.

※グリースニップル及びプラグの主要寸法は9ページ表3、10ページ表5に示す。



NIP-B6

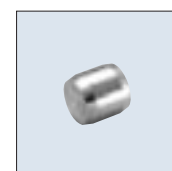

SEN6

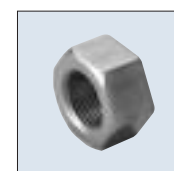

1M12

Dimensions 寸法 mm							Basic load ratings 基本動 N 基本静 定格荷重 kgf 定格荷重		Track load capacity トラック負荷容量 N		Limiting speed 許容回転速度 r/min		Maximum tightening torque 締付最大トルク N·m kgf·m	Mass 質量 kg (approx.) (参考)	Stud dia. スタッド径 mm
G_1	B_3	C_1	n	a	e	h	C_r	C_{or}	Spherical outer ring 球面外輪	Cylindrical outer ring 円筒外輪	Grease lubrication グリース潤滑	Oil lubrication 油潤滑			
5	—	0.5	—	—	7	2.5	2 500 255	2 610 267	560 57	1 360 139	*25 000	*32 000	0.5 0.05	0.005	3
6	—	0.5	—	—	8.5	2.5	3 500 360	3 800 385	725 74	1 790 183	*20 000	*27 000	1 0.1	0.008	4
7.5	—	0.5	—	—	9.5	3	4 500 455	5 350 545	805 82	2 220 226	*17 000	*22 000	2 0.2	0.011	5
8	—	0.6	—	—	12	3	6 500 665	9 350 955	1 080 110	3 400 350	*13 000	*16 000	3 0.3	0.020	6
10	—	0.6	—	—	14	4	7 450 760	11 700 1 190	1 380 141	4 050 415	10 000	*13 000	8 0.8	0.032	8
12	—	0.6	4	—	17	4	8 200 840	14 000 1 420	1 690 172	5 150 525	8 500	*11 000	14 1.4	0.047	10
12	—	0.6	4	—	17	4	8 200 840	14 000 1 420	2 120 216	6 100 620	8 500	*11 000	14 1.4	0.061	10
13	6	0.6	6	3	23	6	12 000 1 230	20 300 2 070	2 620 267	7 700 785	6 500	8 500	20 2	0.089	12
13	6	0.6	6	3	23	6	12 000 1 230	20 300 2 070	2 860 291	8 200 835	6 500	8 500	20 2	0.100	12
17	8	0.8	6	3	27	6	17 600 1 790	34 000 3 500	3 200 325	11 900 1 220	5 500	7 000	52 5.3	0.172	16
19	8	0.8	6	3	32	6	19 400 1 980	42 000 4 250	3 850 390	14 500 1 480	4 500	6 000	76 7.8	0.252	18
21	9	0.8	8	4	37	8	28 800 2 940	61 000 6 250	4 700 480	21 000 2 150	4 000	5 000	98 10	0.392	20
21	9	0.8	8	4	37	8	28 800 2 940	61 000 6 250	5 550 565	23 300 2 370	4 000	5 000	98 10	0.465	20
25	11	0.8	8	4	44	8	39 500 4 000	98 500 10 000	6 950 710	34 500 3 500	3 300	4 500	178 18	0.800	24
25	11	0.8	8	4	44	8	39 500 4 000	98 500 10 000	8 050 820	38 500 3 900	3 300	4 500	178 18	1.05	24
32	15	1	8	4	53	8	58 000 5 900	147 000 15 000	9 800 1 000	53 000 5 400	2 600	3 500	360 37	1.56	30
32	15	1	8	4	53	8	58 000 5 900	147 000 15 000	11 400 1 160	59 000 6 100	2 600	3 500	360 37	1.97	30

Note: The limiting speed of the KRV·LLH and KR·XLLH types incorporating a seal (those marked with an asterisk) is approximately 10,000 rpm.

備考 ※印シール有リKRV·LLH形、KR·XLLH形の許容回転速度はおよそ10 000r/minである。

Metric series	Inch series	
With cage	Full-complement roller	
Hexagonal socket	Tapped hole	Slot for screwdriver
Without seal	With seal	
ミリ系	インチ系	
保持器付	総ころ	
六角穴	タップ穴	ドライバ溝
シールなし	シール付	

Full-Complement Roller-Type Cam Followers

総ころ形カムフォロア

KRV type
KRV··X type
KRV··LL type
KRV··XLL type

KRV形
KRV··X形
KRV··LL形
KRV··XLL形

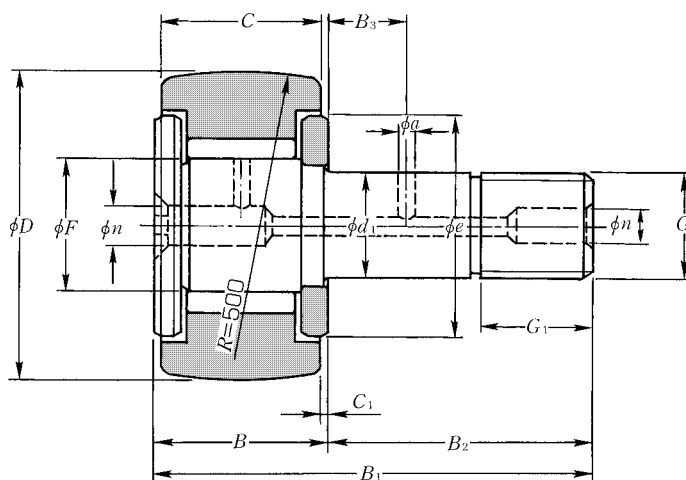
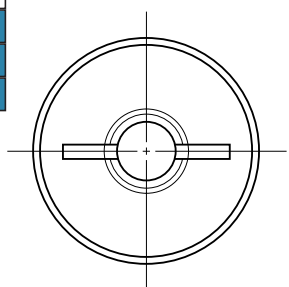

KRV type (Full-complement roller type)

KRV形 (総ころ形)

OD ¹⁾ 外径 mm D	Cam Follower number 呼び番号				Dimensions 寸法 mm						
	Without seal シールなし		With seal シール有り		d ₁	C	F	B	B ₁	B ₂	G
	Spherical outer rings 球面外輪	Cylindrical outer rings 円筒外輪	Spherical outer rings 球面外輪	Cylindrical outer rings 円筒外輪							
0 -0.05											
16	KRV16/3AS	KRV16X/3AS	KRV16LL/3AS	KRV16XLL/3AS	6 ⁰ _{-0.012}	11	8	12	28	16	M6×1
19	KRV19/3AS	KRV19X/3AS	KRV19LL/3AS	KRV19XLL/3AS	8 ⁰ _{-0.015}	11	10	12	32	20	M8×1.25
22	KRV22/3AS	KRV22X/3AS	KRV22LL/3AS	KRV22XLL/3AS	10 ⁰ _{-0.015}	12	12	13	36	23	M10×1.25
26	KRV26/3AS	KRV26X/3AS	KRV26LL/3AS	KRV26XLL/3AS	10 ⁰ _{-0.015}	12	12	13	36	23	M10×1.25
30	KRV30/3AS	KRV30X/3AS	KRV30LL/3AS	KRV30XLL/3AS	12 ⁰ _{-0.018}	14	15	15	40	25	M12×1.5
32	KRV32/3AS	KRV32X/3AS	KRV32LL/3AS	KRV32XLL/3AS	12 ⁰ _{-0.018}	14	15	15	40	25	M12×1.5
35	KRV35/3AS	KRV35X/3AS	KRV35LL/3AS	KRV35XLL/3AS	16 ⁰ _{-0.018}	18	18	19.5	52	32.5	M16×1.5
40	KRV40/3AS	KRV40X/3AS	KRV40LL/3AS	KRV40XLL/3AS	18 ⁰ _{-0.018}	20	22	21.5	58	36.5	M18×1.5
47	KRV47/3AS	KRV47X/3AS	KRV47LL/3AS	KRV47XLL/3AS	20 ⁰ _{-0.021}	24	25	25.5	66	40.5	M20×1.5
52	KRV52/3AS	KRV52X/3AS	KRV52LL/3AS	KRV52XLL/3AS	20 ⁰ _{-0.021}	24	25	25.5	66	40.5	M20×1.5
62	KRV62/3AS	KRV62X/3AS	KRV62LL/3AS	KRV62XLL/3AS	24 ⁰ _{-0.021}	29	30	30.5	80	49.5	M24×1.5
72	KRV72/3AS	KRV72X/3AS	KRV72LL/3AS	KRV72XLL/3AS	24 ⁰ _{-0.021}	29	30	30.5	80	49.5	M24×1.5
80	KRV80/3AS	KRV80X/3AS	KRV80LL/3AS	KRV80XLL/3AS	30 ⁰ _{-0.021}	35	38	37	100	63	M30×1.5
90	KRV90/3AS	KRV90X/3AS	KRV90LL/3AS	KRV90XLL/3AS	30 ⁰ _{-0.021}	35	38	37	100	63	M30×1.5

Notes: 1. JIS class 0 is the dimensional tolerance of outside diameter *D* of the outer rings of the KRV··X and KRV··XLL types whose outside surface form is cylindrical.

2. The grease port is situated only in the front (in the left side face in the diagram above).

注1) 外径面が円筒であるKRV··X形、KRV··XLL形の外輪外径*D*の許容差はJIS 0級である。

2) グリースの補給穴は正面(上図左側面)にだけ設けている。

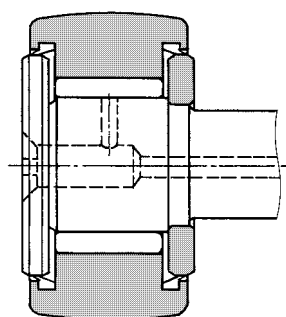

**KRV··LL type
(Full-complement roller type, with seal)**

KRV··LL形 (総ころシール形)

Accessories / 付属部品

Applicable bearing number 適用軸受 呼び番号	Grease nipple number グリースニップル 呼び番号	Plug number プラグ 呼び番号	Applicable hexagonal nut 適用六角ナット
16~26	NIP-B4	SEN4	1M 6×1 ~1M10×1.25
30~40	NIP-B6	SEN6	1M12×1.5~1M18×1.5
47~90	NIP-B8	SEN8	1M20×1.5~1M30×1.5

Note: The boundary dimensions of grease nipples and plugs are listed in **Table 3** on page 9 and **Table 5** on page 10.

※グリースニップル及びプラグの主要寸法は9ページ表3、10ページ表5に示す。



NIP-B6

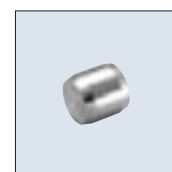

SEN6

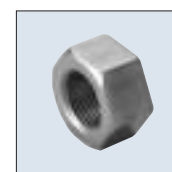

1M12

Dimensions 寸法 mm						Basic load ratings 基本動 N 基本静 定格荷重 kgf 定格荷重		Track load capacity トラック負荷容量 N		Limiting speed 許容回転速度 r/min		Maximum tightening torque 締付最大トルク N·m kgf·m	Mass 質量 kg (approx.) (参考)	Stud dia. スタッド径 mm
G_1	B_3	C_1	n	a	e	C_r	C_{or}	Spherical outer ring 球面外輪	Cylindrical outer ring 円筒外輪	Grease lubrication グリース潤滑	Oil lubrication 油潤滑			
8	—	0.6	4 ²⁾	—	12	6 500 665	9 350 955	1 080 110	3 400 350	*13 000	*16 000	3 0.3	0.020	6
10	—	0.6	4 ²⁾	—	14	7 450 760	11 700 1 190	1 380 141	4 050 415	10 000	*13 000	8 0.8	0.032	8
12	—	0.6	4	—	17	8 200 840	14 000 1 420	1 690 172	5 150 525	8 500	*11 000	14 1.4	0.047	10
12	—	0.6	4	—	17	8 200 840	14 000 1 420	2 120 216	6 100 620	8 500	*11 000	14 1.4	0.061	10
13	6	0.6	6	3	23	12 000 1 230	20 300 2 070	2 620 267	7 700 785	6 500	8 500	20 2	0.089	12
13	6	0.6	6	3	23	12 000 1 230	20 300 2 070	2 860 291	8 200 835	6 500	8 500	20 2	0.100	12
17	8	0.8	6	3	27	17 600 1 790	34 000 3 500	3 200 325	11 900 1 220	5 500	7 000	52 5.3	0.172	16
19	8	0.8	6	3	32	19 400 1 980	42 000 4 250	3 850 390	14 500 1 480	4 500	6 000	76 7.8	0.252	18
21	9	0.8	8	4	37	28 800 2 940	61 000 6 250	4 700 480	21 000 2 150	4 000	5 000	98 10	0.390	20
21	9	0.8	8	4	37	28 800 2 940	61 000 6 250	5 550 565	23 300 2 370	4 000	5 000	98 10	0.465	20
25	11	0.8	8	4	44	39 500 4 000	98 500 10 000	6 950 710	34 500 3 500	3 300	4 500	178 18	0.800	24
25	11	0.8	8	4	44	39 500 4 000	98 500 10 000	8 050 820	38 500 3 900	3 300	4 500	178 18	1.05	24
32	15	1	8	4	53	58 000 5 900	147 000 15 000	9 800 1 000	53 000 5 400	2 600	3 500	360 37	1.56	30
32	15	1	8	4	53	58 000 5 900	147 000 15 000	11 400 1 160	59 000 6 100	2 600	3 500	360 37	1.97	30

Note: The limiting speed of the KRV··LL and KR··XLL types incorporating a seal (those marked with an asterisk) is approximately 10,000 rpm.

備考 ※印シール有KRV··LL形、KRV··XLL形の許容回転速度はおおよそ10 000r/minである。

Metric series	Inch series	
With cage	Full-complement roller	
Hexagonal socket	Tapped hole	Slot for screwdriver
Without seal	With seal	
ミリ系	インチ系	
保持器付	総ころ	
六角穴	タップ穴	ドライバ溝
シールなし	シール付	

Cam Followers with Cage

保持器付カムフォロア

KRT type
KRT··X type
KRT··LL type
KRT··XLL type

KRT形
KRT··X形
KRT··LL形
KRT··XLL形

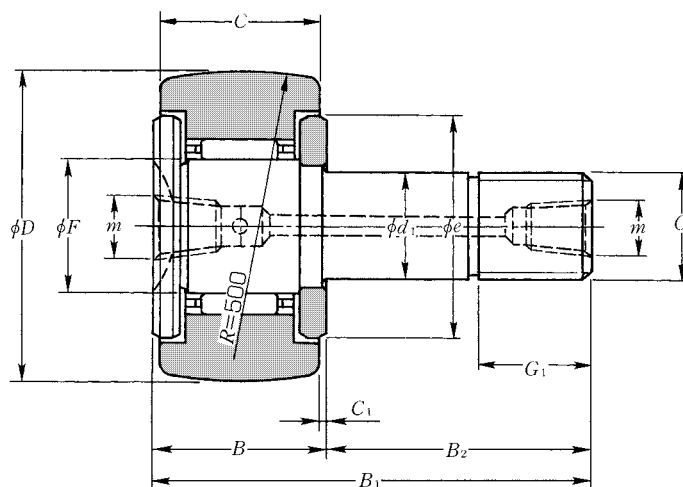
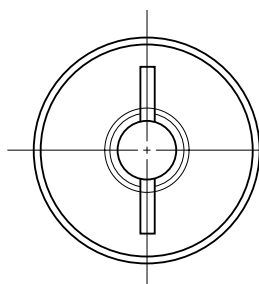

KRT type (with cage)

KRT形 (保持器付)

OD ¹⁾ 外径 mm D	Cam Follower number 呼び番号				Dimensions 寸法 mm						
	Without seal シールなし		With seal シール有り		d ₁	C	F	B	B ₁	B ₂	G
	Spherical outer rings 球面外輪	Cylindrical outer rings 円筒外輪	Spherical outer rings 球面外輪	Cylindrical outer rings 円筒外輪							
0 -0.05											
16	KRT16	KRT16X	KRT16LL/3AS	KRT16XLL/3AS	6 ⁰ _{-0.012}	11	8	12	28	16	M6×1
19	KRT19	KRT19X	KRT19LL/3AS	KRT19XLL/3AS	8 ⁰ _{-0.015}	11	10	12	32	20	M8×1.25
22	KRT22	KRT22X	KRT22LL/3AS	KRT22XLL/3AS	10 ⁰ _{-0.015}	12	12	13	36	23	M10×1.25
26	KRT26	KRT26X	KRT26LL/3AS	KRT26XLL/3AS	10 ⁰ _{-0.015}	12	12	13	36	23	M10×1.25
30	KRT30	KRT30X	KRT30LL/3AS	KRT30XLL/3AS	12 ⁰ _{-0.018}	14	15	15	40	25	M12×1.5
32	KRT32	KRT32X	KRT32LL/3AS	KRT32XLL/3AS	12 ⁰ _{-0.018}	14	15	15	40	25	M12×1.5
35	KRT35	KRT35X	KRT35LL/3AS	KRT35XLL/3AS	16 ⁰ _{-0.018}	18	18	19.5	52	32.5	M16×1.5
40	KRT40	KRT40X	KRT40LL/3AS	KRT40XLL/3AS	18 ⁰ _{-0.018}	20	22	21.5	58	36.5	M18×1.5
47	KRT47	KRT47X	KRT47LL/3AS	KRT47XLL/3AS	20 ⁰ _{-0.021}	24	25	25.5	66	40.5	M20×1.5
52	KRT52	KRT52X	KRT52LL/3AS	KRT52XLL/3AS	20 ⁰ _{-0.021}	24	25	25.5	66	40.5	M20×1.5
62	KRT62	KRT62X	KRT62LL/3AS	KRT62XLL/3AS	24 ⁰ _{-0.021}	29	30	30.5	80	49.5	M24×1.5
72	KRT72	KRT72X	KRT72LL/3AS	KRT72XLL/3AS	24 ⁰ _{-0.021}	29	30	30.5	80	49.5	M24×1.5
80	KRT80	KRT80X	KRT80LL/3AS	KRT80XLL/3AS	30 ⁰ _{-0.021}	35	38	37	100	63	M30×1.5
85	KRT85	KRT85X	KRT85LL/3AS	KRT85XLL/3AS	30 ⁰ _{-0.021}	35	38	37	100	63	M30×1.5
90	KRT90	KRT90X	KRT90LL/3AS	KRT90XLL/3AS	30 ⁰ _{-0.021}	35	38	37	100	63	M30×1.5

Notes: 1. JIS class 0 is the dimensional tolerance of outside diameter *D* of the outer rings of the KRT··X and KRT··XLL types whose outside surface form is cylindrical.

2. The tapped hole is situated only in the front (in the left side face in the diagram above).

注1) 外径面が円筒であるKRT··X形、KRT··XLL形の外輪外径*D*の許容差はJIS 0級である。

2) タップ穴は正面（上図左側面）にだけ設けている。

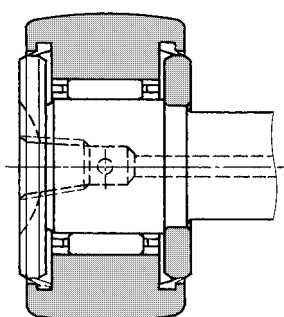

KRT·LL type (with cage, sealed)

KRT·LL形（保持器付シール形）

Accessories / 付属部品

Applicable bearing number 適用軸受 呼び番号	Grease nipple number グリースニップル 呼び番号	Plug number プラグ 呼び番号	Applicable Hexagonal Nut Number 適用六角ナット 呼び番号
16~26	NIP-X30	M4×0.7 ×4 ℓ	1M 6×1 ~1M10×1.25
30~32	JIS-A-M6F	M6×0.75×6 ℓ	1M12×1.5
35~90	JIS-A PT $\frac{1}{8}$	PT $\frac{1}{8}$ ×7 ℓ	1M16×1.5~1M30×1.5

Note: The boundary dimensions of grease nipples and plugs are listed in **Table 3** on page 9 and **Table 5** on page 10.

※グリースニップル及びプラグの主要寸法は9ページ表3、10ページ表5に示す。



JIS A PT $\frac{1}{8}$



PT $\frac{1}{8}$

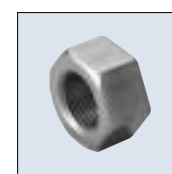

1M12

Dimensions 寸法 mm				Basic load ratings 基本動 N 基本静 定格荷重 kgf 定格荷重		Track load capacity トラック負荷容量 N		Limiting speed 許容回転速度 r/min		Maximum tightening torque 締付最大トルク N·m kgf·m	Mass 質量 kg (approx.) (参考)	Stud dia. スタッド径 mm
G ₁	C ₁	m	e	C _r	C _{or}	Spherical outer ring 球面外輪 kgf	Cylindrical outer ring 円筒外輪 kgf	Grease lubrication グリース潤滑	Oil lubrication 油潤滑			
8	0.6	M4×0.7 ²⁾	12	4 050 415	4 200 430	1 080 110	3 400 350	*19 000	*25 000	3 0.3	0.019	6
10	0.6	M4×0.7 ²⁾	14	4 750 480	5 400 555	1 380 141	4 050 415	*15 000	*20 000	8 0.8	0.031	8
12	0.6	M4×0.7	17	5 300 540	6 650 680	1 690 172	5 150 525	*12 000	*16 000	14 1.4	0.046	10
12	0.6	M4×0.7	17	5 300 540	6 650 680	2 120 216	6 100 620	*12 000	*16 000	14 1.4	0.059	10
13	0.6	M6×0.75	23	7 850 800	9 650 985	2 620 267	7 700 785	10 000	*13 000	20 2	0.087	12
13	0.6	M6×0.75	23	7 850 800	9 650 985	2 860 291	8 200 835	10 000	*13 000	20 2	0.097	12
17	0.8	PT $\frac{1}{8}$	27	12 200 1 240	17 900 1 830	3 200 325	11 900 1 220	8 000	*11 000	52 5.3	0.169	16
19	0.8	PT $\frac{1}{8}$	32	14 000 1 430	22 800 2 330	3 850 390	14 500 1 480	7 000	9 000	76 7.8	0.248	18
21	0.8	PT $\frac{1}{8}$	37	20 700 2 110	33 500 3 450	4 700 480	21 000 2 150	6 000	8 000	98 10	0.386	20
21	0.8	PT $\frac{1}{8}$	37	20 700 2 110	33 500 3 450	5 550 565	23 300 2 370	6 000	8 000	98 10	0.461	20
25	0.8	PT $\frac{1}{8}$	44	28 900 2 950	55 000 5 600	6 950 710	34 500 3 500	5 000	6 500	178 18	0.790	24
25	0.8	PT $\frac{1}{8}$	44	28 900 2 950	55 000 5 600	8 050 820	38 500 3 900	5 000	6 500	178 18	1.04	24
32	1	PT $\frac{1}{8}$	53	45 000 4 600	88 500 9 050	9 800 1 000	53 000 5 400	4 000	5 500	360 37	1.55	30
32	1	PT $\frac{1}{8}$	53	45 000 4 600	88 500 9 050	10 400 1 060	56 000 5 750	4 000	5 500	360 37	1.74	30
32	1	PT $\frac{1}{8}$	53	45 000 4 600	88 500 9 050	11 400 1 160	59 000 6 100	4 000	5 500	360 37	1.95	30

Note: The limiting speed of the KRT·LL and KRT·XLL types incorporating a seal (those marked with an asterisk) is approximately 10,000 rpm.

備考 ※印シール有KRT·LL形、KRT·XLL形の許容回転速度はおおよそ10 000 r/minである。

Metric series	Inch series	
With cage	Full-complement roller	
Hexagonal socket	Tapped hole	Slot for screwdriver
Without seal	With seal	
ミリ系	インチ系	
保持器付	総ころ	
六角穴	タップ穴	ドライバ溝
シールなし	シール付	

Full-Complement Roller-Type Cam Followers

総ころ形カムフォロア

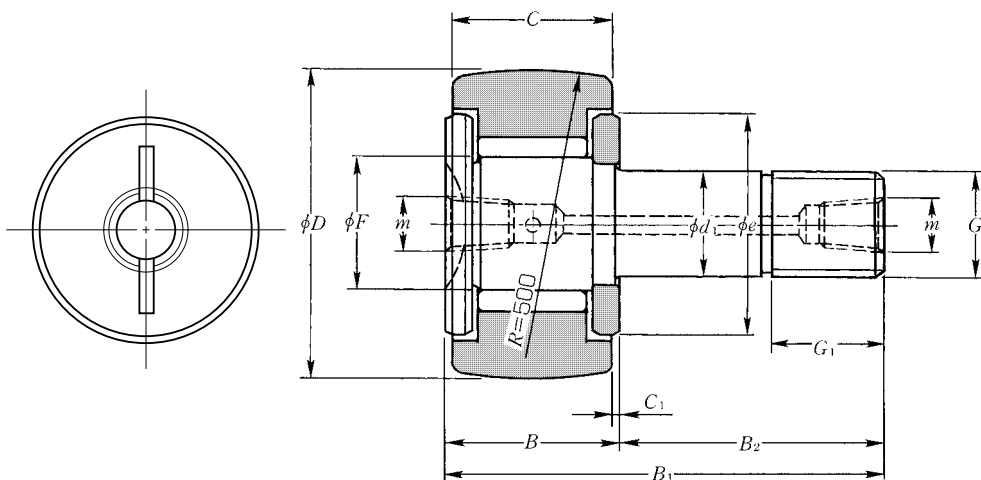

KRVT type (Full-complement roller type)

KRVT形 (総ころ形)

OD ¹⁾ 外径 mm D	Cam Follower number 呼び番号				Dimensions 寸法 mm						
	Without seal シールなし		With seal シール有り		d_1	C	F	B	B_1	B_2	G
	Spherical outer rings 球面外輪	Cylindrical outer rings 円筒外輪	Spherical outer rings 球面外輪	Cylindrical outer rings 円筒外輪							
0 -0.05											
16	KRVT16/3AS	KRVT16X/3AS	KRVT16LL/3AS	KRVT16XLL/3AS	$6 \begin{smallmatrix} 0 \\ -0.012 \end{smallmatrix}$	11	8	12	28	16	M6×1
19	KRVT19/3AS	KRVT19X/3AS	KRVT19LL/3AS	KRVT19XLL/3AS	$8 \begin{smallmatrix} 0 \\ -0.015 \end{smallmatrix}$	11	10	12	32	20	M8×1.25
22	KRVT22/3AS	KRVT22X/3AS	KRVT22LL/3AS	KRVT22XLL/3AS	$10 \begin{smallmatrix} 0 \\ -0.015 \end{smallmatrix}$	12	12	13	36	23	M10×1.25
26	KRVT26/3AS	KRVT26X/3AS	KRVT26LL/3AS	KRVT26XLL/3AS	$10 \begin{smallmatrix} 0 \\ -0.015 \end{smallmatrix}$	12	12	13	36	23	M10×1.25
30	KRVT30/3AS	KRVT30X/3AS	KRVT30LL/3AS	KRVT30XLL/3AS	$12 \begin{smallmatrix} 0 \\ -0.018 \end{smallmatrix}$	14	15	15	40	25	M12×1.5
32	KRVT32/3AS	KRVT32X/3AS	KRVT32LL/3AS	KRVT32XLL/3AS	$12 \begin{smallmatrix} 0 \\ -0.018 \end{smallmatrix}$	14	15	15	40	25	M12×1.5
35	KRVT35/3AS	KRVT35X/3AS	KRVT35LL/3AS	KRVT35XLL/3AS	$16 \begin{smallmatrix} 0 \\ -0.018 \end{smallmatrix}$	18	18	19.5	52	32.5	M16×1.5
40	KRVT40/3AS	KRVT40X/3AS	KRVT40LL/3AS	KRVT40XLL/3AS	$18 \begin{smallmatrix} 0 \\ -0.018 \end{smallmatrix}$	20	22	21.5	58	36.5	M18×1.5
47	KRVT47/3AS	KRVT47X/3AS	KRVT47LL/3AS	KRVT47XLL/3AS	$20 \begin{smallmatrix} 0 \\ -0.021 \end{smallmatrix}$	24	25	25.5	66	40.5	M20×1.5
52	KRVT52/3AS	KRVT52X/3AS	KRVT52LL/3AS	KRVT52XLL/3AS	$20 \begin{smallmatrix} 0 \\ -0.021 \end{smallmatrix}$	24	25	25.5	66	40.5	M20×1.5
62	KRVT62/3AS	KRVT62X/3AS	KRVT62LL/3AS	KRVT62XLL/3AS	$24 \begin{smallmatrix} 0 \\ -0.021 \end{smallmatrix}$	29	30	30.5	80	49.5	M24×1.5
72	KRVT72/3AS	KRVT72X/3AS	KRVT72LL/3AS	KRVT72XLL/3AS	$24 \begin{smallmatrix} 0 \\ -0.021 \end{smallmatrix}$	29	30	30.5	80	49.5	M24×1.5
80	KRVT80/3AS	KRVT80X/3AS	KRVT80LL/3AS	KRVT80XLL/3AS	$30 \begin{smallmatrix} 0 \\ -0.021 \end{smallmatrix}$	35	38	37	100	63	M30×1.5
90	KRVT90/3AS	KRVT90X/3AS	KRVT90LL/3AS	KRVT90XLL/3AS	$30 \begin{smallmatrix} 0 \\ -0.021 \end{smallmatrix}$	35	38	37	100	63	M30×1.5

Notes:1. JIS Class 0 is the dimensional tolerance of the outside diameter D of the outer rings of the KRVT·X and KRVT·XLL types whose outside surface form is cylindrical.

2. The grease port is situated only in the front (in the left side face in the diagram above).

注1) 外径面が円筒であるKRVT·X形、KRVT·XLLの外輪外径 D の許容差はJIS 0級である。

2) タップ穴は正面(上図左側面)にだけ設けている。

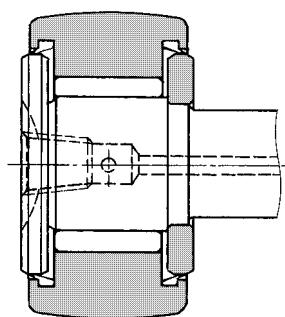

**KRVT··LL type
(Full-complement roller type, with seal)**

KRVT··LL形 (総ころシール形)

Accessories / 付属部品

Applicable bearing number 適用軸受 呼び番号	Grease nipple number グリースニップル 呼び番号	Plug number プラグ 呼び番号	Applicable Hexagonal Nut Number 適用六角ナット 呼び番号
16~26	NIP-X30	M4×0.7 ×4 ℓ	1M 6×1 ~1M10×1.25
30~32	JIS-A-M6F	M6×0.75×6 ℓ	1M12×1.5
35~90	JIS-A PT $\frac{1}{8}$	PT $\frac{1}{8}$ ×7 ℓ	1M16×1.5~1M30×1.5

Note: The boundary dimensions of grease nipples and plugs are listed in **Table 3** on page 9 and **Table 5** on page 10.

※グリースニップル及びプラグの主要寸法は9ページ表3、10ページ表5に示す。



JIS A PT $\frac{1}{8}$



PT $\frac{1}{8}$



1M12

Dimensions 寸法 mm				Basic load ratings 基本動 N 基本静 定格荷重 kgf 定格荷重		Track load capacity トラック負荷容量 N		Limiting speed 許容回転速度 r/min		Maximum tightening torque 締付最大トルク N·m kgf·m	Mass 質量 kg (approx.) (参考)	Stud dia. スタッド径 mm
G_1	C_1	m	e	C_r	C_{or}	Spherical outer ring 球面外輪	Cylindrical outer ring 円筒外輪	Grease lubrication グリース潤滑	Oil lubrication 油潤滑			
8	0.6	M4X0.7 ²⁾	12	6 500 665	9 350 955	1 080 110	3 400 350	*13 000	*16 000	3 0.3	0.020	6
10	0.6	M4X0.7 ²⁾	14	7 450 760	11 700 1 190	1 380 141	4 050 415	10 000	*13 000	8 0.8	0.032	8
12	0.6	M4X0.7	17	8 200 840	14 000 1 420	1 690 172	5 150 525	8 500	*11 000	14 1.4	0.047	10
12	0.6	M4X0.7	17	8 200 840	14 000 1 420	2 120 216	6 100 620	8 500	*11 000	14 1.4	0.061	10
13	0.6	M6X0.75	23	12 000 1 230	20 300 2 070	2 620 267	7 700 785	6 500	8 500	20 2	0.089	12
13	0.6	M6X0.75	23	12 000 1 230	20 300 2 070	2 860 291	8 200 835	6 500	8 500	20 2	0.100	12
17	0.8	PT $\frac{1}{8}$	27	17 600 1 790	34 000 3 500	3 200 325	11 900 1 220	5 500	7 000	52 5.3	0.172	16
19	0.8	PT $\frac{1}{8}$	32	19 400 1 980	42 000 4 250	3 850 390	14 500 1 480	4 500	6 000	76 7.8	0.252	18
21	0.8	PT $\frac{1}{8}$	37	28 800 2 940	61 000 6 250	4 700 480	21 000 2 150	4 000	5 000	98 10	0.390	20
21	0.8	PT $\frac{1}{8}$	37	28 800 2 940	61 000 6 250	5 550 565	23 300 2 370	4 000	5 000	98 10	0.465	20
25	0.8	PT $\frac{1}{8}$	44	39 500 4 000	98 500 10 000	6 950 710	34 500 3 500	3 300	4 500	178 18	0.800	24
25	0.8	PT $\frac{1}{8}$	44	39 500 4 000	98 500 10 000	8 050 820	38 500 3 900	3 300	4 500	178 18	1.05	24
32	1	PT $\frac{1}{8}$	53	58 000 5 900	147 000 15 000	9 800 1 000	53 000 5 400	2 600	3 500	360 37	1.56	30
32	1	PT $\frac{1}{8}$	53	58 000 5 900	147 000 15 000	11 400 1 160	59 000 6 100	2 600	3 500	360 37	1.97	30

Note: The limiting speed of the KRVT··LL and KRVT··XLL types incorporating a seal (those marked with an asterisk) is approximately 10,000 rpm.

備考 ※印シール有リKRVT··LL形、KRVT··XLL形の許容回転速度はおおよそ10 000 r/minである。

Metric series	Inch series	
With cage	Full-complement roller	
Hexagonal socket	Tapped hole	Slot for screwdriver
Without seal	With seal	
Eccentric stud		
ミリ系	インチ系	
保持器付	総ころ	
六角穴	タップ穴	ドライバ溝
シールなし	シール付	
軸 偏 心		

KRU type
KRU··X type
KRU··LL type
KRU··XLL type

KRU形
KRU··X形
KRU··LL形
KRU··XLL形

Eccentric-Stud Cam Followers with Cage

スタッド偏心保持器付きカムフォロア

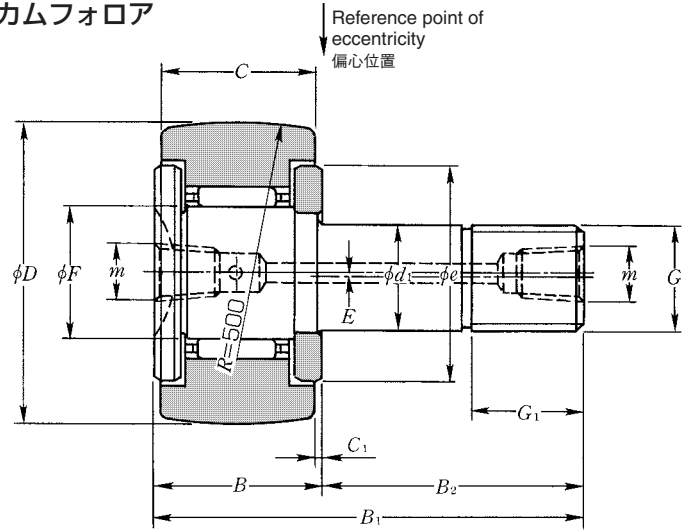
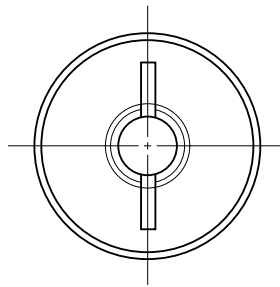

KRU type (with cage)
KRU形 (保持器付)

OD ¹⁾ 外径 mm <i>D</i> 0 -0.05	Cam Follower number 呼び番号				Dimensions 寸法 mm						
	Without seal シールなし		With seal シール有り		<i>d</i> ₁	<i>C</i>	<i>F</i>	<i>B</i>	<i>B</i> ₁	<i>B</i> ₂	<i>G</i>
	Spherical outer rings 球面外輪	Cylindrical outer rings 円筒外輪	Spherical outer rings 球面外輪	Cylindrical outer rings 円筒外輪							
16	KRU16	KRU16X	KRU16LL/3AS	KRU16XLL/3AS	6 ⁰ _{-0.012}	11	8	12	28	16	M6×1
19	KRU19	KRU19X	KRU19LL/3AS	KRU19XLL/3AS	8 ⁰ _{-0.015}	11	10	12	32	20	M8×1.25
22	KRU22	KRU22X	KRU22LL/3AS	KRU22XLL/3AS	10 ⁰ _{-0.015}	12	12	13	36	23	M10×1.25
26	KRU26	KRU26X	KRU26LL/3AS	KRU26XLL/3AS	10 ⁰ _{-0.015}	12	12	13	36	23	M10×1.25
30	KRU30	KRU30X	KRU30LL/3AS	KRU30XLL/3AS	12 ⁰ _{-0.018}	14	15	15	40	25	M12×1.5
32	KRU32	KRU32X	KRU32LL/3AS	KRU32XLL/3AS	12 ⁰ _{-0.018}	14	15	15	40	25	M12×1.5
35	KRU35	KRU35X	KRU35LL/3AS	KRU35XLL/3AS	16 ⁰ _{-0.018}	18	19	19.5	52	32.5	M16×1.5
40	KRU40	KRU40X	KRU40LL/3AS	KRU40XLL/3AS	18 ⁰ _{-0.018}	20	22	21.5	58	36.5	M18×1.5
47	KRU47	KRU47X	KRU47LL/3AS	KRU47XLL/3AS	20 ⁰ _{-0.021}	24	25	25.5	66	40.5	M20×1.5
52	KRU52	KRU52X	KRU52LL/3AS	KRU52XLL/3AS	20 ⁰ _{-0.021}	24	25	25.5	66	40.5	M20×1.5
62	KRU62	KRU62X	KRU62LL/3AS	KRU62XLL/3AS	24 ⁰ _{-0.021}	29	30	30.5	80	49.5	M24×1.5
72	KRU72	KRU72X	KRU72LL/3AS	KRU72XLL/3AS	24 ⁰ _{-0.021}	29	30	30.5	80	49.5	M24×1.5
80	KRU80	KRU80X	KRU80LL/3AS	KRU80XLL/3AS	30 ⁰ _{-0.021}	35	38	37	100	63	M30×1.5
85	KRU85	KRU85X	KRU85LL/3AS	KRU85XLL/3AS	30 ⁰ _{-0.021}	35	38	37	100	63	M30×1.5
90	KRU90	KRU90X	KRU90LL/3AS	KRU90XLL/3AS	30 ⁰ _{-0.021}	35	38	37	100	63	M30×1.5

Notes: 1. JIS Class 0 is the dimensional tolerance of the outside diameter *D* of the outer rings of the KRU··X and KRU··XLL types whose outside surface form is cylindrical.

2. The grease port is situated only in the front (in the left side face in the diagram above).

注1) 外径面が円筒であるKRU··X形、KRU··XLL形の外輪外径*D*の許容差はJIS 0級である。

2) タップ穴は正面(上図左側面)にだけ設けている。

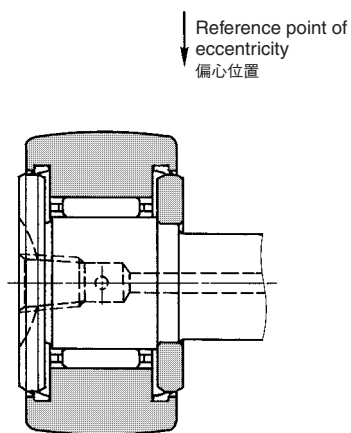

KRU··LL type (with cage)
KRU··LL形 (保持器付)

Accessories / 付属部品

Applicable bearing number 適用軸受 呼び番号	Grease nipple number グリースニップル 呼び番号	Plug number プラグ 呼び番号	Applicable Hexagonal Nut Number 適用六角ナット 呼び番号
16~26	NIP-X30	M4×0.7 ×4 ℓ	1M 6×1 ~1M10×1.25
30~35	JIS-A-M6F	M6×0.75×6 ℓ	1M12×1.5~1M16×1.5
40~90	JIS-A PT $\frac{1}{8}$	PT $\frac{1}{8}$ ×7 ℓ	1M18×1.5~1M30×1.5

Note: The boundary dimensions of grease nipples and plugs are listed in **Table 3** on page 9 and **Table 5** on page 10.

※グリースニップル及びプラグの主要寸法は9ページ表3、10ページ表5に示す。



JIS A PT $\frac{1}{8}$



PT $\frac{1}{8}$



1M12

G ₁	Dimensions 寸法 mm				Basic load ratings 基本動 N 基本静 定格荷重 kgf 定格荷重		Track load capacity トラック負荷容量 N		Limiting speed 許容回転速度 r/min		Maximum tightening torque 締付最大トルク N·m kgf·m	Mass 質量 kg (approx.) (参考)	Stud dia. スタッド径 mm
	Eccentricity 偏心率 E	C ₁	m	e	C _r	C _{or}	Spherical outer ring 球面外輪	Cylindrical outer ring 円筒外輪	Grease lubrication グリース潤滑	Oil lubrication 油潤滑			
8	0.25	0.6	M4X0.7 ²⁾	12	4 050 415	4 200 430	1 080 110	3 400 350	*19 000	*25000	3 0.3	0.019	6
10	0.25	0.6	M4X0.7 ²⁾	14	4 750 480	5 400 555	1 380 141	4 050 415	*15 000	*20 000	8 0.8	0.031	8
12	0.3	0.6	M4X0.7	17	5 300 540	6 650 680	1 690 172	5 150 525	*12 000	*16 000	14 1.4	0.046	10
12	0.3	0.6	M4X0.7	17	5 300 540	6 650 680	2 120 216	6 100 620	*12 000	*16 000	14 1.4	0.059	10
13	0.4	0.6	M6X0.75	23	7 850 800	9 650 985	2 620 267	7 700 785	10 000	*13 000	20 2	0.087	12
13	0.4	0.6	M6X0.75	23	7 850 800	9 650 985	2 860 291	8 200 835	10 000	*13 000	20 2	0.097	12
17	0.5	0.8	M6X0.75	27	12 500 1 280	18 000 1 930	3 200 325	11 900 1 220	8 000	*11 000	52 5.3	0.169	16
19	0.6	0.8	PT $\frac{1}{8}$	32	14 000 1 430	22 800 2 330	3 850 390	14 500 1 480	7 000	9 000	76 7.8	0.248	18
21	0.7	0.8	PT $\frac{1}{8}$	37	20 700 2 110	33 500 3 450	4 700 480	21 000 2 150	6 000	8 000	98 10	0.386	20
21	0.7	0.8	PT $\frac{1}{8}$	37	20 700 2 110	33 500 3 450	5 550 565	23 300 2 370	6 000	8 000	98 10	0.461	20
25	0.8	0.8	PT $\frac{1}{8}$	44	28 900 2 950	55 000 5 600	6 950 710	34 500 3 500	5 000	6 500	178 18	0.790	24
25	0.8	0.8	PT $\frac{1}{8}$	44	28 900 2 950	55 000 5 600	8 050 820	38 500 3 900	5 000	6 500	178 18	1.04	24
32	1.0	1	PT $\frac{1}{8}$	53	45 000 4 600	88 500 9 050	9 800 1 000	53 000 5 400	4 000	5 500	360 37	1.55	30
32	1.0	1	PT $\frac{1}{8}$	53	45 000 4 600	88 500 9 050	10 400 1 060	56 000 5 750	4 000	5 500	360 37	1.74	30
32	1.0	1	PT $\frac{1}{8}$	53	45 000 4 600	88 500 9 050	11 400 1 160	59 000 6 100	4 000	5 500	360 37	1.95	30

Note: The limiting speed of the KRU··LL and KRU··XLL types incorporating a seal (those marked with an asterisk) is approximately 10,000 rpm.

備考 ※印シール有リKRU··LL形、KRU··XLL形の許容回転速度はおおよそ10 000 r/minである。

Metric series	Inch series	
With cage	Full-complement roller	
Hexagonal socket	Tapped hole	Slot for screwdriver
Without seal	With seal	
Eccentric stud		
ミリ系	インチ系	
保持器付	総ころ	
六角穴	タップ穴	ドライバ溝
シールなし	シール付	
軸 偏 心		

KRVU type
KRVU··X type
KRVU··LL type
KRVU··XLL type

KRVU形
KRVU··X形
KRVU··LL形
KRVU··XLL形

Eccentric-Stud Full-Complement Roller-Type Cam Followers

総ころ形スタッド偏心カムフォロア

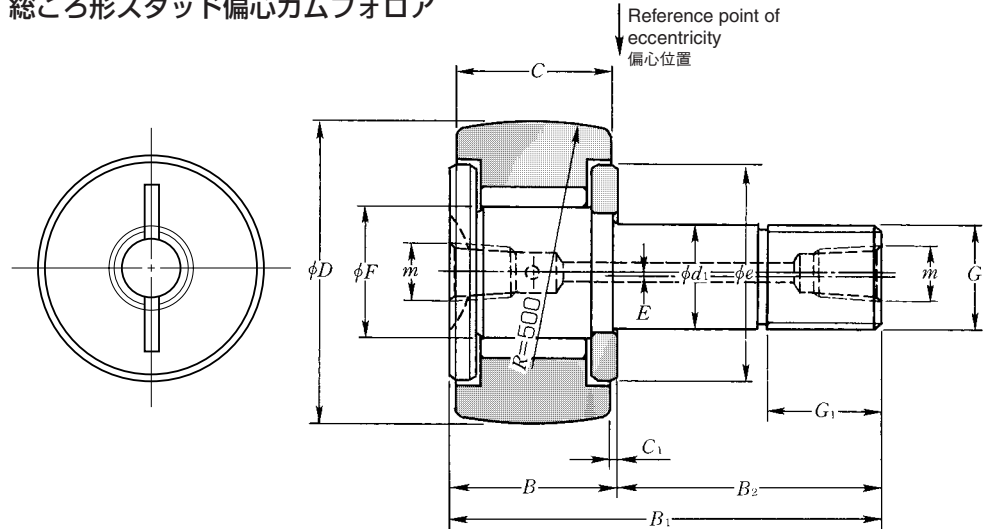

KRVU type (Full-complement roller type)

KRVU形 (総ころ形)

OD ¹⁾ 外径 mm D	Cam Follower number 呼び番号				Dimensions 寸法 mm						
	Without seal シールなし		With seal シール有り		d_1	C	F	B	B_1	B_2	G
	Spherical outer rings 球面外輪	Cylindrical outer rings 円筒外輪	Spherical outer rings 球面外輪	Cylindrical outer rings 円筒外輪							
0 -0.05											
16	KRVU16/3AS	KRVU16X/3AS	KRVU16LL/3AS	KRVU16XLL/3AS	$6 \begin{smallmatrix} 0 \\ -0.012 \end{smallmatrix}$	11	8	12	28	16	M6×1
19	KRVU19/3AS	KRVU19X/3AS	KRVU19LL/3AS	KRVU19XLL/3AS	$8 \begin{smallmatrix} 0 \\ -0.015 \end{smallmatrix}$	11	10	12	32	20	M8×1.25
22	KRVU22/3AS	KRVU22X/3AS	KRVU22LL/3AS	KRVU22XLL/3AS	$10 \begin{smallmatrix} 0 \\ -0.015 \end{smallmatrix}$	12	12	13	36	23	M10×1.25
26	KRVU26/3AS	KRVU26X/3AS	KRVU26LL/3AS	KRVU26XLL/3AS	$10 \begin{smallmatrix} 0 \\ -0.015 \end{smallmatrix}$	12	12	13	36	23	M10×1.25
30	KRVU30/3AS	KRVU30X/3AS	KRVU30LL/3AS	KRVU30XLL/3AS	$12 \begin{smallmatrix} 0 \\ -0.018 \end{smallmatrix}$	14	15	15	40	25	M12×1.5
32	KRVU32/3AS	KRVU32X/3AS	KRVU32LL/3AS	KRVU32XLL/3AS	$12 \begin{smallmatrix} 0 \\ -0.018 \end{smallmatrix}$	14	15	15	40	25	M12×1.5
35	KRVU35/3AS	KRVU35X/3AS	KRVU35LL/3AS	KRVU35XLL/3AS	$16 \begin{smallmatrix} 0 \\ -0.018 \end{smallmatrix}$	18	19	19.5	52	32.5	M16×1.5
40	KRVU40/3AS	KRVU40X/3AS	KRVU40LL/3AS	KRVU40XLL/3AS	$18 \begin{smallmatrix} 0 \\ -0.018 \end{smallmatrix}$	20	22	21.5	58	36.5	M18×1.5
47	KRVU47/3AS	KRVU47X/3AS	KRVU47LL/3AS	KRVU47XLL/3AS	$20 \begin{smallmatrix} 0 \\ -0.021 \end{smallmatrix}$	24	25	25.5	66	40.5	M20×1.5
52	KRVU52/3AS	KRVU52X/3AS	KRVU52LL/3AS	KRVU52XLL/3AS	$20 \begin{smallmatrix} 0 \\ -0.021 \end{smallmatrix}$	24	25	25.5	66	40.5	M20×1.5
62	KRVU62/3AS	KRVU62X/3AS	KRVU62LL/3AS	KRVU62XLL/3AS	$24 \begin{smallmatrix} 0 \\ -0.021 \end{smallmatrix}$	29	30	30.5	80	49.5	M24×1.5
72	KRVU72/3AS	KRVU72X/3AS	KRVU72LL/3AS	KRVU72XLL/3AS	$24 \begin{smallmatrix} 0 \\ -0.021 \end{smallmatrix}$	29	30	30.5	80	49.5	M24×1.5
80	KRVU80/3AS	KRVU80X/3AS	KRVU80LL/3AS	KRVU80XLL/3AS	$30 \begin{smallmatrix} 0 \\ -0.021 \end{smallmatrix}$	35	38	37	100	63	M30×1.5
90	KRVU90/3AS	KRVU90X/3AS	KRVU90LL/3AS	KRVU90XLL/3AS	$30 \begin{smallmatrix} 0 \\ -0.021 \end{smallmatrix}$	35	38	37	100	63	M30×1.5

Notes: 1. JIS Class 0 is the dimensional tolerance of the outside diameter D of the outer rings of the KRVU··X and KRVU··XLL types whose outside surface form is cylindrical.

2. The grease port is situated only in the front (in the left side face in the diagram above).

注1) 外径面が円筒であるKRVU··X形、KRVU··XLL形の外輪外径 D の許容差はJIS 0級である。

2) タップ穴は正面(上図左側面)にだけ設けている。

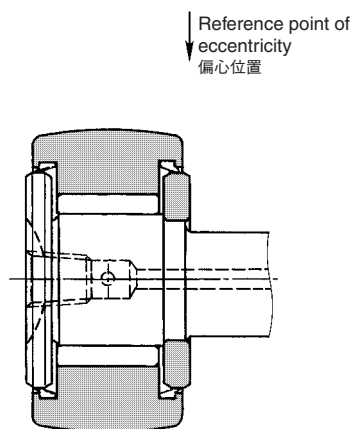

KRVU·LL type
(Full-complement roller type, with seal)
 KRVU·LL形 (総ころシール形)

Accessories / 付属部品

Applicable bearing number 適用軸受 呼び番号	Grease nipple number グリースニップル 呼び番号	Plug number プラグ 呼び番号	Applicable Hexagonal Nut Number 適用六角ナット 呼び番号
16~26	NIP-X30	M4×0.7 ×4 ℓ	1M 6×1 ~1M10×1.25
30~35	JIS-A-M6F	M6×0.75×6 ℓ	1M12×1.5~1M16×1.5
40~90	JIS-A PT $\frac{1}{8}$	PT $\frac{1}{8}$ ×7 ℓ	1M18×1.5~1M30×1.5

Note: The boundary dimensions of grease nipples and plugs are listed in **Table 3** on page 9 and **Table 5** on page 10.

*グリースニップル及びプラグの主要寸法は9ページ表3、10ページ表5に示す。



JIS A PT $\frac{1}{8}$



PT $\frac{1}{8}$



1M12

Dimensions 寸法 mm					Basic load ratings 基本動 N 基本静 定格荷重 kgf 定格荷重		Track load capacity トラック負荷容量 N		Limiting speed 許容回転速度 r/min		Maximum tightening torque 締付最大トルク N·m kgf·m	Mass 質量 kg (approx.) (参考)	Stud dia. スタッド径 mm
G ₁	Eccentricity 偏心量 E	C ₁	m	e	C _r	C _{or}	Spherical outer ring 球面外輪 kgf	Cylindrical outer ring 円筒外輪	Grease lubrication グリース潤滑	Oil lubrication 油潤滑			
8	0.25	0.6	M4X0.7 ²⁾	12	6 500 665	9 350 955	1 080 110	3 400 350	*13 000	*16 000	3 0.3	0.020	6
10	0.25	0.6	M4X0.7 ²⁾	14	7 450 760	11 700 1 190	1 380 141	4 050 415	10 000	*13 000	8 0.8	0.032	8
12	0.3	0.6	M4X0.7	17	8 200 840	14 000 1 420	1 690 172	5 150 525	8 500	*11 000	14 1.4	0.047	10
12	0.3	0.6	M4X0.7	17	8 200 840	14 000 1 420	2 120 216	6 100 620	8 500	*11 000	14 1.4	0.061	10
13	0.4	0.6	M6X0.75	23	12 000 1 230	20 300 2 070	2 620 267	7 700 785	6 500	8 500	20 2	0.089	12
13	0.4	0.6	M6X0.75	23	12 000 1 230	20 300 2 070	2 860 291	8 200 835	6 500	8 500	20 2	0.100	12
17	0.5	0.8	M6X0.75	27	18 000 1 840	36 500 3 700	3 200 325	11 900 1 220	5 500	7 000	52 5.3	0.172	16
19	0.6	0.8	PT $\frac{1}{8}$	32	19 400 1 980	42 000 4 250	3 850 390	14 500 1 480	4 500	6 000	76 7.8	0.252	18
21	0.7	0.8	PT $\frac{1}{8}$	37	28 800 2 940	61 000 6 250	4 700 480	21 000 2 150	4 000	5 000	98 10	0.390	20
21	0.7	0.8	PT $\frac{1}{8}$	37	28 800 2 940	61 000 6 250	5 550 565	23 300 2 370	4 000	5 000	98 10	0.465	20
25	0.8	0.8	PT $\frac{1}{8}$	44	39 500 4 000	98 500 10 000	6 950 710	34 500 3 500	3 300	4 500	178 18	0.800	24
25	0.8	0.8	PT $\frac{1}{8}$	44	39 500 4 000	98 500 10 000	8 050 820	38 500 3 900	3 300	4 500	178 18	1.05	24
32	1.0	1	PT $\frac{1}{8}$	53	58 000 5 900	147 000 15 000	9 800 1 000	53 000 5 400	2 600	3 500	360 37	1.56	30
32	1.0	1	PT $\frac{1}{8}$	53	58 000 5 900	147 000 15 000	11 400 1 160	59 000 6 100	2 600	3 500	360 37	1.97	30

Note: The limiting speed of the KRVU·LL and KRVU·XLL types incorporating a seal (those marked with an asterisk) is approximately 10,000 rpm.

備考 *印シール有りKRVU·LL形、KRVU·XLL形の許容回転速度はおおよそ10 000 r/minである。

Metric series	Inch series	
With cage	Full-complement roller	
Hexagonal socket	Tapped hole	Slot for screwdriver
Without shield	With shield	
ミリ系	インチ系	
保持器付	総ころ	
六角穴	タップ穴	ドライバ溝
シールドなし	シールド付	

Full-Complement Double-Row Cylindrical Roller-Type Cam Followers

総ころ複列円筒ころ形カムフォロア

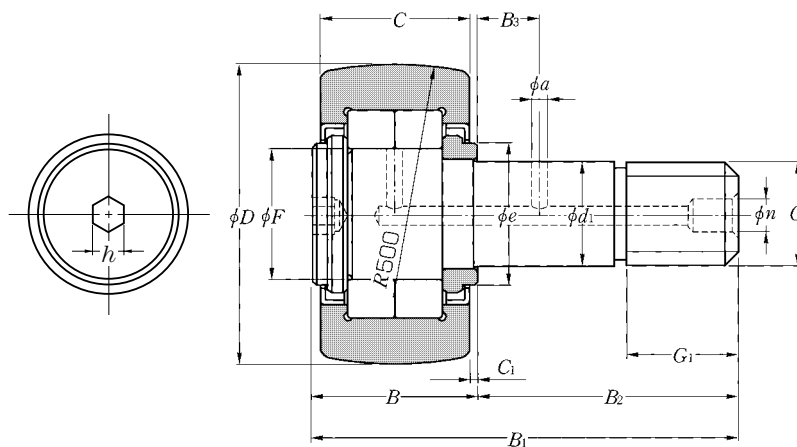

NUKR··H type NUKR··XH type

NUKR··H形
NUKR··XH形

NUKR··H type ($D < 100\text{mm}$)
(Shielded full-complement double-row cylindrical roller type)
NUKR··H形 ($D < 100\text{mm}$)
(シールド付総ころ複列円筒ころ形)

OD ¹⁾ 外径 mm D 0 -0.05	Cam Follower number 呼び番号		Dimensions 寸法 mm										
	Spherical outer rings 球面外輪	Cylindrical outer rings 円筒外輪	d_1	C	F	B	B_1	B_2	G	G_1	B_3	C_1	n
30	NUKR30H/3AS	NUKR30XH/3AS	12 ⁰ _{-0.018}	14	14.5	15	40	25	M12×1.5	13	6	0.6	6
35	NUKR35H/3AS	NUKR35XH/3AS	16 ⁰ _{-0.018}	18	19	19.5	52	32.5	M16×1.5	17	8	0.8	6
40	NUKR40H/3AS	NUKR40XH/3AS	18 ⁰ _{-0.018}	20	21.5	21.5	58	36.5	M18×1.5	19	8	0.8	6
47	NUKR47H/3AS	NUKR47XH/3AS	20 ⁰ _{-0.021}	24	25.5	25.5	66	40.5	M20×1.5	21	9	0.8	8
52	NUKR52H/3AS	NUKR52XH/3AS	20 ⁰ _{-0.021}	24	30	25.5	66	40.5	M20×1.5	21	9	0.8	8
62	NUKR62H/3AS	NUKR62XH/3AS	24 ⁰ _{-0.021}	29	35	30.5	80	49.5	M24×1.5	25	11	0.8	8
72	NUKR72H/3AS	NUKR72XH/3AS	24 ⁰ _{-0.021}	29	41.5	30.5	80	49.5	M24×1.5	25	11	0.8	8
80	NUKR80H/3AS	NUKR80XH/3AS	30 ⁰ _{-0.021}	35	47.5	37	100	63	M30×1.5	32	15	1	8
90	NUKR90H/3AS	NUKR90XH/3AS	30 ⁰ _{-0.021}	35	47.5	37	100	63	M30×1.5	32	15	1	8
100	NUKR100H/3AS	NUKR100XH/3AS	36 ⁰ _{-0.025}	43	48.5	46	120	74	M36×1.5	38	—	1.5	—
120	NUKR120H/3AS	NUKR120XH/3AS	42 ⁰ _{-0.025}	50	60.5	53	140	87	M42×1.5	44	—	1.5	—
140	NUKR140H/3AS	NUKR140XH/3AS	48 ⁰ _{-0.025}	57	65	60	160	100	M48×1.5	52	—	1.5	—
150	NUKR150H/3AS	NUKR150XH/3AS	52 ⁰ _{-0.030}	60	75.5	63	170	107	M52×1.5	52	—	1.5	—
160	NUKR160H/3AS	NUKR160XH/3AS	56 ⁰ _{-0.030}	63	80.5	67	180	113	M56×3	58	—	2	—
170	NUKR170H/3AS	NUKR170XH/3AS	60 ⁰ _{-0.030}	66	86	70	190	120	M60×3	58	—	2	—
180	NUKR180H/3AS	NUKR180XH/3AS	64 ⁰ _{-0.030}	72	91.5	76	200	124	M64×3	65	—	2	—

Note:1. JIS Class 0 is the dimensional tolerance of the outside diameter D of the outer rings of the NUKR··XH type whose outside surface form is cylindrical.
注1) 外径面が円筒であるNUKR··XH形の外輪外径 D の許容差はJIS 0級である。

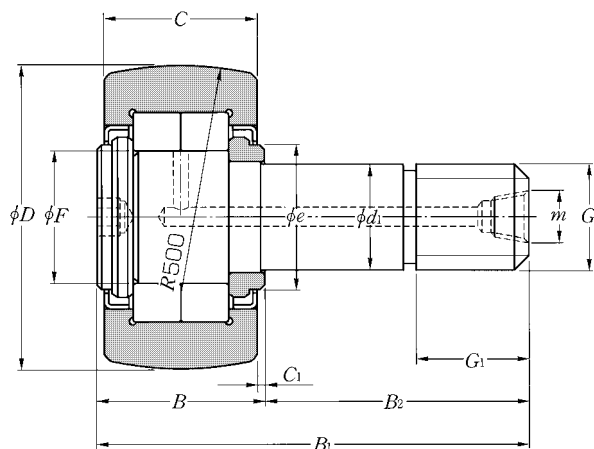

NUKR··H type ($D \geq 100\text{mm}$)
NUKR··H形 ($D \geq 100\text{mm}$)

Accessories / 付属部品

Applicable bearing number 適用軸受 呼び番号	Grease nipple number グリースニップル 呼び番号	Plug number プラグ 呼び番号	Applicable hexagonal nut 適用六角ナット
30~40	NIP-B6	SEN6	1M12×1.5~1M18×1.5
47~90	NIP-B8	SEN8	1M20×1.5~1M30×1.5
100~180	JIS A-PT $\frac{1}{8}$	—	M36×1.5~ M64×3

Note: The boundary dimensions of the grease nipples and plugs are listed in Table 3 on page 9 and Table 5 on page 10.

※グリースニップル及びプラグの主要寸法は9ページ表3、10ページ表5に示す。

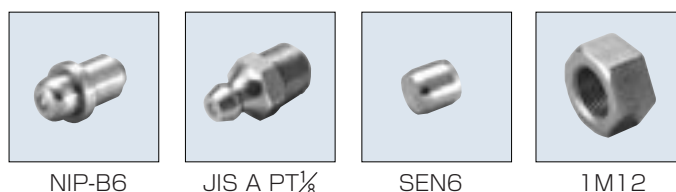

NIP-B6

JIS A PT $\frac{1}{8}$

SEN6

1M12

Dimensions 寸法 mm				Basic load ratings		Track load capacity		Limiting speed 許容回転速度 r/min Grease lubrication グリース潤滑	Maximum tightening torque 締付最大トルク N·m kgf·m	Mass 質量 kg (approx.) (参考)	Stud dia. スタッド径 mm
m	a	e	h	dynamic	static	N					
				C_r	C_{or}	Spherical outer ring 球面外輪	Cylindrical outer ring 円筒外輪	基本動 定格荷重	基本静 定格荷重	kgf	kgf
—	3	15	6	13 300 1 360	13 500 1 380	2 620 267	7 700 785	6 900	20 2	0.088	12
—	3	21	6	22 300 2 280	25 700 2 620	3 200 325	11 900 1 220	5 500	52 5.3	0.165	16
—	3	23	6	24 100 2 450	29 100 2 970	3 850 390	14 500 1 480	4 700	76 7.8	0.242	18
—	4	27	8	38 500 3 950	48 000 4 900	4 700 480	21 000 2 150	4 000	98 10	0.380	20
—	4	31	8	42 500 4 350	57 500 5 850	5 550 565	23 300 2 370	3 300	98 10	0.450	20
—	4	38	8	56 500 5 750	72 500 7 400	6 950 710	34 500 3 500	2 900	178 18	0.795	24
—	4	44	8	62 000 6 350	85 500 8 700	8 050 820	38 500 3 900	2 400	178 18	1.01	24
—	4	51	8	101 000 10 300	151 000 15 400	9 800 1 000	53 000 5 400	2 100	360 37	1.54	30
—	4	51	8	101 000 10 300	151 000 15 400	11 400 1 160	59 000 6 100	2 100	360 37	1.96	30
PT $\frac{1}{8}$	—	53	14	119 000 12 100	167 000 17 000	13 000 1 300	79 000 8 050	2 000	630 65	3.08	36
PT $\frac{1}{8}$	—	66	14	172 000 17 600	266 000 27 100	16 400 1 670	113 000 11 500	1 700	1 020 105	5.17	42
PT $\frac{1}{8}$	—	72.5	14	201 000 20 500	294 000 30 000	20 000 2 040	152 000 15 500	1 500	1 540 160	7.98	48
PT $\frac{1}{8}$	—	85.5	17	258 000 26 300	380 000 39 000	22 000 2 250	173 000 17 600	1 300	1 950 200	9.70	52
PT $\frac{1}{8}$	—	89.5	17	274 000 27 900	400 000 41 000	24 000 2 450	194 000 19 800	1 200	2 480 250	11.7	56
PT $\frac{1}{8}$	—	96.5	17	320 000 32 500	475 000 48 500	26 000 2 650	218 000 22 200	1 100	3 030 310	13.9	60
PT $\frac{1}{8}$	—	103.5	17	365 000 37 500	555 000 56 500	27 900 2 840	253 000 25 800	1 000	3 670 375	17.0	64

Metric series	Inch series	
With cage	Full-complement roller	
Hexagonal socket	Tapped hole	Slot for screwdriver
Without shield	With shield	
ミリ系	インチ系	
保持器付	総ころ	
六角穴	タップ穴	ドライバ溝
シールドなし	シールド付	

NUKR type
NUKR··X type

NUKR形
NUKR··X形

Full-Complement Double-Row Cylindrical Roller-Type Cam Followers
総ころ複列円筒ころ形カムフォロア

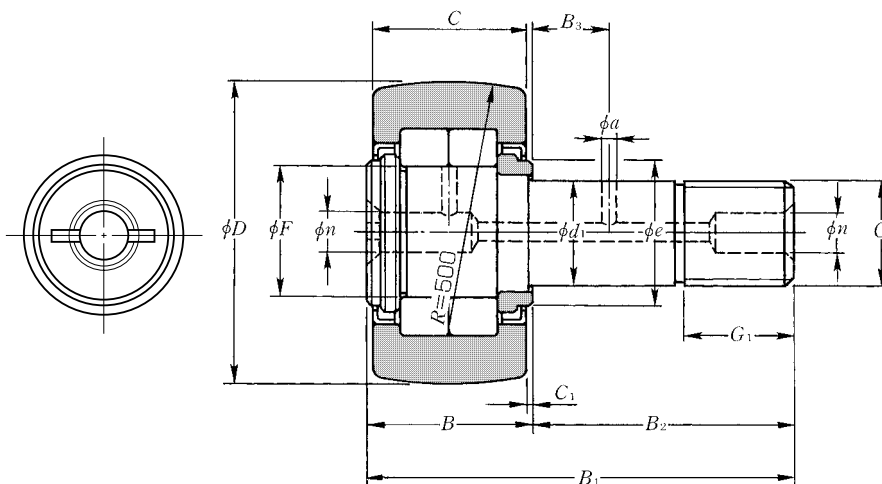

NUKR type ($D < 100\text{mm}$)
(Shielded full-complement double-row cylindrical roller type)
NUKR形 ($D < 100\text{mm}$) (シールド付総ころ複列円筒ころ形)

OD ¹⁾ 外径 mm D 0 -0.05	Cam Follower number 呼び番号		Dimensions 寸法 mm										
	Spherical outer rings 球面外輪	Cylindrical outer rings 円筒外輪	d_1	C	F	B	B_1	B_2	G	G_1	B_3	C_1	n
30	NUKR 30/3AS	NUKR 30X/3AS	12 ⁰ _{-0.018}	14	14.5	15	40	25	M12×1.5	13	6	0.6	6
35	NUKR 35/3AS	NUKR 35X/3AS	16 ⁰ _{-0.018}	18	19	19.5	52	32.5	M16×1.5	17	8	0.8	6
40	NUKR 40/3AS	NUKR 40X/3AS	18 ⁰ _{-0.018}	20	21.5	21.5	58	36.5	M18×1.5	19	8	0.8	6
47	NUKR 47/3AS	NUKR 47X/3AS	20 ⁰ _{-0.021}	24	25.5	25.5	66	40.5	M20×1.5	21	9	0.8	8
52	NUKR 52/3AS	NUKR 52X/3AS	20 ⁰ _{-0.021}	24	30	25.5	66	40.5	M20×1.5	21	9	0.8	8
62	NUKR 62/3AS	NUKR 62X/3AS	24 ⁰ _{-0.021}	29	35	30.5	80	49.5	M24×1.5	25	11	0.8	8
72	NUKR 72/3AS	NUKR 72X/3AS	24 ⁰ _{-0.021}	29	41.5	30.5	80	49.5	M24×1.5	25	11	0.8	8
80	NUKR 80/3AS	NUKR 80X/3AS	30 ⁰ _{-0.021}	35	47.5	37	100	63	M30×1.5	32	15	1	8
90	NUKR 90/3AS	NUKR 90X/3AS	30 ⁰ _{-0.021}	35	47.5	37	100	63	M30×1.5	32	15	1	8
100	NUKR 100/3AS	NUKR 100X/3AS	36 ⁰ _{-0.025}	43	48.5	46	120	74	M36×1.5	38	—	1.5	8
120	NUKR 120/3AS	NUKR 120X/3AS	42 ⁰ _{-0.025}	50	60.5	53	140	87	M42×1.5	44	—	1.5	8
140	NUKR 140/3AS	NUKR 140X/3AS	48 ⁰ _{-0.025}	57	65	60	160	100	M48×1.5	52	—	1.5	8
150	NUKR 150/3AS	NUKR 150X/3AS	52 ⁰ _{-0.030}	60	75.5	63	170	107	M52×1.5	52	—	1.5	8
160	NUKR 160/3AS	NUKR 160X/3AS	56 ⁰ _{-0.030}	63	80.5	67	180	113	M56×3	58	—	2	8
170	NUKR 170/3AS	NUKR 170X/3AS	60 ⁰ _{-0.030}	66	86	70	190	120	M60×3	58	—	2	8
180	NUKR 180/3AS	NUKR 180X/3AS	64 ⁰ _{-0.030}	72	91.5	76	200	124	M64×3	65	—	2	8

Note:1. JIS Class 0 is the dimensional tolerance of the outside diameter D of the outer rings of the NUKR··X type whose outside surface form is cylindrical.
注1) 外径面が円筒であるNUKR··X形の外輪外径 D の許容差はJIS 0級である。

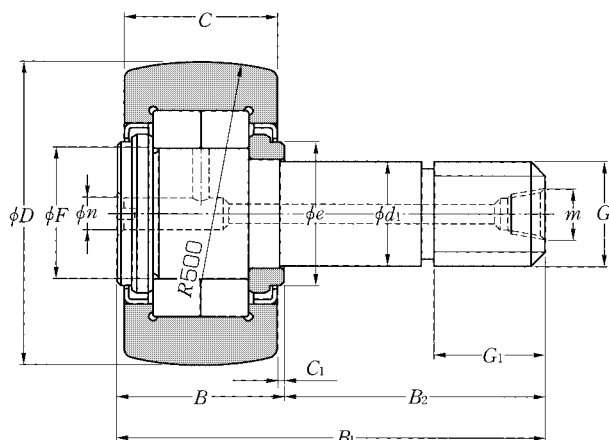

NUKR type ($D \geq 100\text{mm}$)
NUKR形 ($D \geq 100\text{mm}$)

Accessories / 付属部品

Applicable bearing number 適用軸受 呼び番号	Grease nipple number グリースニップル 呼び番号	Plug number プラグ 呼び番号	Applicable hexagonal nut 適用六角ナット
30~40	NIP-B6	SEN6	1M12×1.5~1M18×1.5
47~90	NIP-B8	SEN8	1M20×1.5~1M30×1.5
100~180	JIS A-PT $\frac{1}{8}$	SEN8	M36×1.5~ M64×3

Note: The boundary dimensions of the grease nipples and plugs are listed in Table 3 on page 9 and Table 5 on page 10.

※グリースニップル及びプラグの主要寸法は9ページ表3、10ページ表5に示す。

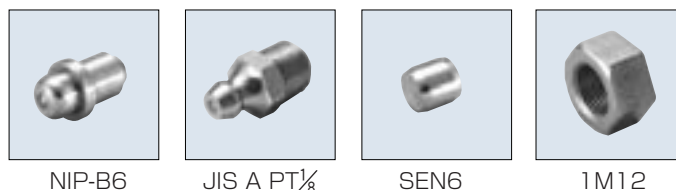

Dimensions 寸法 mm			Basic load ratings		Track load capacity		Limiting speed 許容回転速度 r/min Grease lubrication グリース潤滑	Maximum tightening torque 締付最大トルク N·m kgf·m	Mass 質量 kg (approx.) (参考)	Stud dia. スタッド径 mm
m	a	e	dynamic	static	トラック負荷容量					
			C_r	C_{or}	Spherical outer ring 球面外輪	Cylindrical outer ring 円筒外輪	N	N		
—	3	15	13 300 1 360	13 500 1 380	2 620 267	7 700 785	6 900	20 2	0.088	12
—	3	21	22 300 2 280	25 700 2 620	3 200 325	11 900 1 220	5 500	52 5.3	0.165	16
—	3	23	24 100 2 450	29 100 2 970	3 850 390	14 500 1 480	4 700	76 7.8	0.242	18
—	4	27	38 500 3 950	48 000 4 900	4 700 480	21 000 2 150	4 000	98 10	0.380	20
—	4	31	42 500 4 350	57 500 5 850	5 550 565	23 300 2 370	3 300	98 10	0.450	20
—	4	38	56 500 5 750	72 500 7 400	6 950 710	34 500 3 500	2 900	178 18	0.795	24
—	4	44	62 000 6 350	85 500 8 700	8 050 820	38 500 3 900	2 400	178 18	1.01	24
—	4	51	101 000 10 300	151 000 15 400	9 800 1 000	53 000 5 400	2 100	360 37	1.54	30
—	4	51	101 000 10 300	151 000 15 400	11 400 1 160	59 000 6 100	2 100	360 37	1.96	30
PT $\frac{1}{8}$	—	53	119 000 12 100	167 000 17 000	13 000 1 300	79 000 8 050	2 000	630 65	3.08	36
PT $\frac{1}{8}$	—	66	172 000 17 600	266 000 27 100	16 400 1 670	113 000 11 500	1 700	1 020 105	5.17	42
PT $\frac{1}{8}$	—	72.5	201 000 20 500	294 000 30 000	20 000 2 040	152 000 15 500	1 500	1 540 160	7.98	48
PT $\frac{1}{8}$	—	85.5	258 000 26 300	380 000 39 000	22 000 2 250	173 000 17 600	1 300	1 950 200	9.70	52
PT $\frac{1}{8}$	—	89.5	274 000 27 900	400 000 41 000	24 000 2 450	194 000 19 800	1 200	2 480 250	11.7	56
PT $\frac{1}{8}$	—	96.5	320 000 32 500	475 000 48 500	26 000 2 650	218 000 22 200	1 100	3 030 310	13.9	60
PT $\frac{1}{8}$	—	103.5	365 000 37 500	555 000 56 500	27 900 2 840	253 000 25 800	1 000	3 670 375	17.0	64

Metric series	Inch series	
With cage	Full-complement roller	
Hexagonal socket	Tapped hole	Slot for screwdriver
Without shield	With shield	
ミリ系	インチ系	
保持器付	総ころ	
六角穴	タップ穴	ドライバ溝
シールドなし	シールド付	

Full-Complement Double-Row Cylindrical Roller-Type Cam Followers

総ころ複列円筒ころ形カムフォロア

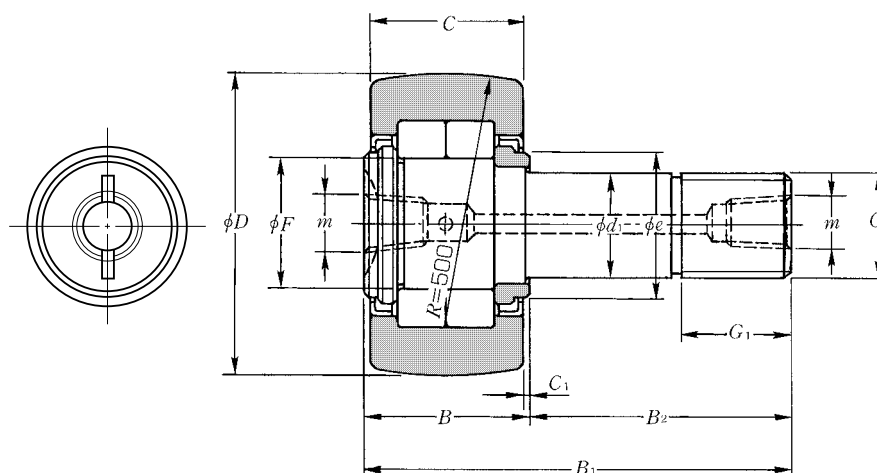

NUKRT type
(Shielded full-complement double-row cylindrical roller type)
NUKRT形 (シールド付総ころ複列円筒ころ形)

OD ¹⁾ 外径 mm D 0 -0.05	Cam Follower number 呼び番号		Dimensions 寸法 mm										
	Spherical outer rings 球面外輪	Cylindrical outer rings 円筒外輪	d ₁	C	F	B	B ₁	B ₂	G	G ₁	C ₁	m	e
30	NUKRT 30/3AS	NUKRT 30X/3AS	12 ⁰ _{-0.018}	14	14.5	15	40	25	M12×1.5	13	0.6	M6×0.75	15
35	NUKRT 35/3AS	NUKRT 35X/3AS	16 ⁰ _{-0.018}	18	19	19.5	52	32.5	M16×1.5	17	0.8	PT ¹ / ₈	21
40	NUKRT 40/3AS	NUKRT 40X/3AS	18 ⁰ _{-0.018}	20	21.5	21.5	58	36.5	M18×1.5	19	0.8	PT ¹ / ₈	23
47	NUKRT 47/3AS	NUKRT 47X/3AS	20 ⁰ _{-0.021}	24	25.5	25.5	66	40.5	M20×1.5	21	0.8	PT ¹ / ₈	27
52	NUKRT 52/3AS	NUKRT 52X/3AS	20 ⁰ _{-0.021}	24	30	25.5	66	40.5	M20×1.5	21	0.8	PT ¹ / ₈	31
62	NUKRT 62/3AS	NUKRT 62X/3AS	24 ⁰ _{-0.021}	29	35	30.5	80	49.5	M24×1.5	25	0.8	PT ¹ / ₈	38
72	NUKRT 72/3AS	NUKRT 72X/3AS	24 ⁰ _{-0.021}	29	41.5	30.5	80	49.5	M24×1.5	25	0.8	PT ¹ / ₈	44
80	NUKRT 80/3AS	NUKRT 80X/3AS	30 ⁰ _{-0.021}	35	47.5	37	100	63	M30×1.5	32	1	PT ¹ / ₈	51
90	NUKRT 90/3AS	NUKRT 90X/3AS	30 ⁰ _{-0.021}	35	47.5	37	100	63	M30×1.5	32	1	PT ¹ / ₈	51
100	NUKRT 100/3AS	NUKRT 100X/3AS	36 ⁰ _{-0.025}	43	48.5	46	120	74	M36×1.5	38	1.5	PT ¹ / ₈	53
120	NUKRT 120/3AS	NUKRT 120X/3AS	42 ⁰ _{-0.025}	50	60.5	53	140	87	M42×1.5	44	1.5	PT ¹ / ₈	66
140	NUKRT 140/3AS	NUKRT 140X/3AS	48 ⁰ _{-0.025}	57	65	60	160	100	M48×1.5	52	1.5	PT ¹ / ₈	72.5
150	NUKRT 150/3AS	NUKRT 150X/3AS	52 ⁰ _{-0.030}	60	75.5	63	170	107	M52×1.5	52	1.5	PT ¹ / ₈	85.5
160	NUKRT 160/3AS	NUKRT 160X/3AS	56 ⁰ _{-0.030}	63	80.5	67	180	113	M56×3	58	2	PT ¹ / ₈	89.5
170	NUKRT 170/3AS	NUKRT 170X/3AS	60 ⁰ _{-0.030}	66	86	70	190	120	M60×3	58	2	PT ¹ / ₈	96.5
180	NUKRT 180/3AS	NUKRT 180X/3AS	64 ⁰ _{-0.030}	72	91.5	76	200	124	M64×3	65	2	PT ¹ / ₈	103.5

Note: 1. JIS Class 0 is the dimensional tolerance of the outside diameter *D* of the outer rings of the NUKRT··X type whose outside surface form is cylindrical.
注1) 外径面が円筒であるNUKRT··X形の外輪外径*D*の許容差はJIS 0級である。

Accessories / 付属部品

Applicable bearing number 適用軸受 呼び番号	Grease nipple number グリースニップル 呼び番号	Plug number プラグ 呼び番号	Applicable hexagonal nut 適用六角ナット
30	JIS A-M6F	M6×0.75×6 ℓ	1M12×1.5
35~180	JIS A-PT $\frac{1}{8}$	PT $\frac{1}{8}$ ×7 ℓ	1M16×1.5~1M64×3

Note: The boundary dimensions of the grease nipples and plugs are listed in Table 3 on page 9 and Table 5 on page 10.

※グリースニップル及びプラグの主要寸法は9ページ表3、10ページ表5に示す。



JIS A PT $\frac{1}{8}$



PT $\frac{1}{8}$

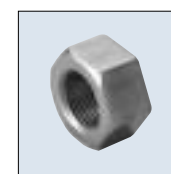

1M12

Basic load ratings		Track load capacity		Limiting speed	Maximum tightening torque	Mass	Stud dia.
dynamic	static	トラック負荷容量					
基本動 定格荷重	N kgf	基本静 定格荷重		許容回転速度 r/min	締付最大トルク N·m	質量 kg	スタッド径
C_r	C_{or}	Spherical outer ring 球面外輪	Cylindrical outer ring 円筒外輪	Grease lubrication グリース潤滑	kgf·m	(approx.) (参考)	mm
13 300 1 360	13 500 1 380	2 620 267	7 700 785	6 900	20 2	0.088	12
22 300 2 280	25 700 2 620	3 200 325	11 900 1 220	5 500	52 5.3	0.165	16
24 100 2 450	29 100 2 970	3 850 390	14 500 1 480	4 700	76 7.8	0.242	18
38 500 3 950	48 000 4 900	4 700 480	21 000 2 150	4 000	98 10	0.380	20
42 500 4 350	57 500 5 850	5 550 565	23 300 2 370	3 300	98 10	0.450	20
56 500 5 750	72 500 7 400	6 950 710	34 500 3 500	2 900	178 18	0.795	24
62 000 6 350	85 500 8 700	8 050 820	38 500 3 900	2 400	178 18	1.01	24
101 000 10 300	151 000 15 400	9 800 1 000	53 000 5 400	2 100	360 37	1.54	30
101 000 10 300	151 000 15 400	11 400 1 160	59 000 6 100	2 100	360 37	1.96	30
119 000 12 100	167 000 17 000	13 000 1 300	79 000 8 050	2 000	630 65	3.08	36
172 000 17 600	266 000 27 100	16 400 1 670	113 000 11 500	1 700	1 020 105	5.17	42
201 000 20 500	294 000 30 000	20 000 2 040	152 000 15 500	1 500	1 540 160	7.98	48
258 000 26 300	380 000 39 000	22 000 2 250	173 000 17 600	1 300	1 950 200	9.70	52
274 000 27 900	400 000 41 000	24 000 2 450	194 000 19 800	1 200	2 480 250	11.7	56
320 000 32 500	475 000 48 500	26 000 2 650	218 000 22 200	1 100	3 030 310	13.9	60
365 000 37 500	555 000 56 500	27 900 2 840	253 000 25 800	1 000	3 670 375	17.0	64

Metric series	Inch series	
With cage	Full-complement roller	
Hexagonal socket	Tapped hole	Slot for screwdriver
Without shield	With shield	
Eccentric stud		
ミリ系	インチ系	
保持器付	総ころ	
六角穴	タップ穴	ドライバ溝
シールドなし	シールド付	
軸 偏 心		

Eccentric-Stud Full-Complement Double-Row Cylindrical Roller-Type Cam Followers

総ころスタッド偏心複列円筒ころ形カムフォロア

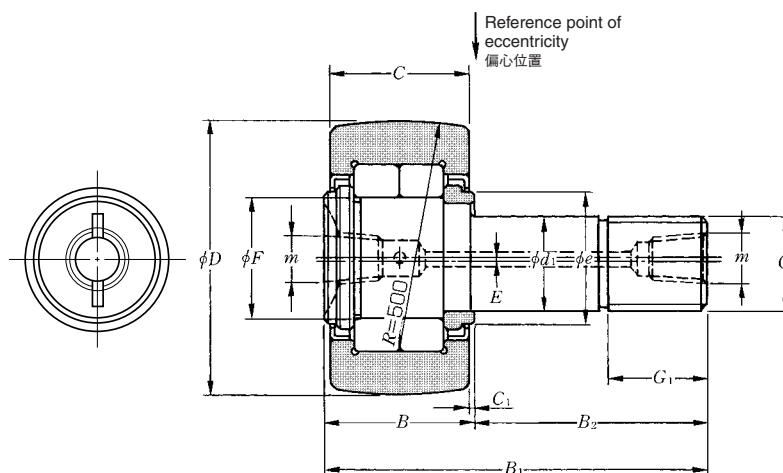

NUKRU type
(Shielded full-complement double-row cylindrical roller type)
NUKRU形 (シールド付総ころ複列円筒ころ形)

OD ¹⁾ 外径 mm D 0 -0.05	Cam Follower number 呼び番号		Dimensions 寸法 mm											Eccentricity 偏心量 E
	Spherical outer rings 球面外輪	Cylindrical outer rings 円筒外輪	d ₁	C	F	B	B ₁	B ₂	G	G ₁	C ₁	m	e	
30	NUKRU 30/3AS	NUKRU 30X/3AS	12 ⁰ _{-0.018}	14	14.5	15	40	25	M12×1.5	13	0.6	M6×0.75	15	0.4
35	NUKRU 35/3AS	NUKRU 35X/3AS	16 ⁰ _{-0.018}	18	19	19.5	52	32.5	M16×1.5	17	0.8	M6×0.75	21	0.5
40	NUKRU 40/3AS	NUKRU 40X/3AS	18 ⁰ _{-0.018}	20	21.5	21.5	58	36.5	M18×1.5	19	0.8	PT ¹ / ₈	23	0.6
47	NUKRU 47/3AS	NUKRU 47X/3AS	20 ⁰ _{-0.021}	24	25.5	25.5	66	40.5	M20×1.5	21	0.8	PT ¹ / ₈	27	0.7
52	NUKRU 52/3AS	NUKRU 52X/3AS	20 ⁰ _{-0.021}	24	30	25.5	66	40.5	M20×1.5	21	0.8	PT ¹ / ₈	31	0.7
62	NUKRU 62/3AS	NUKRU 62X/3AS	24 ⁰ _{-0.021}	29	35	30.5	80	49.5	M24×1.5	25	0.8	PT ¹ / ₈	38	0.8
72	NUKRU 72/3AS	NUKRU 72X/3AS	24 ⁰ _{-0.021}	29	41.5	30.5	80	49.5	M24×1.5	25	0.8	PT ¹ / ₈	44	1.0
80	NUKRU 80/3AS	NUKRU 80X/3AS	30 ⁰ _{-0.021}	35	47.5	37	100	63	M30×1.5	32	1	PT ¹ / ₈	51	1.0
90	NUKRU 90/3AS	NUKRU 90X/3AS	30 ⁰ _{-0.021}	35	47.5	37	100	63	M30×1.5	32	1	PT ¹ / ₈	51	1.0
100	NUKRU 100/3AS	NUKRU 100X/3AS	36 ⁰ _{-0.025}	43	48.5	46	120	74	M36×1.5	38	1.5	PT ¹ / ₈	53	1.5
120	NUKRU 120/3AS	NUKRU 120X/3AS	42 ⁰ _{-0.025}	50	60.5	53	140	87	M42×1.5	44	1.5	PT ¹ / ₈	66	1.5
140	NUKRU 140/3AS	NUKRU 140X/3AS	48 ⁰ _{-0.025}	57	65	60	160	100	M48×1.5	52	1.5	PT ¹ / ₈	72.5	2
150	NUKRU 150/3AS	NUKRU 150X/3AS	52 ⁰ _{-0.030}	60	75.5	63	170	107	M52×1.5	52	1.5	PT ¹ / ₈	85.5	2
160	NUKRU 160/3AS	NUKRU 160X/3AS	56 ⁰ _{-0.030}	63	80.5	67	180	113	M56×3	58	2	PT ¹ / ₈	89.5	2
170	NUKRU 170/3AS	NUKRU 170X/3AS	60 ⁰ _{-0.030}	66	86	70	190	120	M60×3	58	2	PT ¹ / ₈	96.5	2.5
180	NUKRU 180/3AS	NUKRU 180X/3AS	64 ⁰ _{-0.030}	72	91.5	76	200	124	M64×3	65	2	PT ¹ / ₈	103.5	2.5

Note: 1. JIS Class 0 is the dimensional tolerance of the outside diameter *D* of the outer rings of the NUKRU · · X type whose outside surface form is cylindrical.
注1) 外径面が円筒であるNUKRU · · X形の外輪外径 *D* の許容差はJIS 0級である。

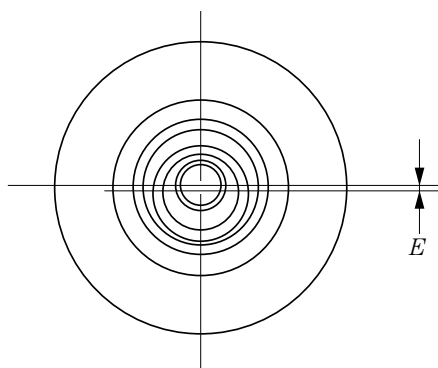

Accessories / 付属部品

Applicable bearing number 適用軸受 呼び番号	Grease nipple number グリースニップル 呼び番号	Plug number プラグ 呼び番号	Applicable hexagonal nut 適用六角ナット
30~35	JIS A-M6F	M6×0.75×6 ℓ	1M12×1.5~1M16×1.5
40~180	JIS A-PT $\frac{1}{8}$	PT $\frac{1}{8}$ ×7 ℓ	1M18×1.5~1M64×3

Note: The boundary dimensions of the grease nipples and plugs are listed in Table 3 on page 9 and Table 5 on page 10.

※グリースニップル及びプラグの主要寸法は9ページ表3、10ページ表5に示す。



JIS A PT $\frac{1}{8}$



PT $\frac{1}{8}$

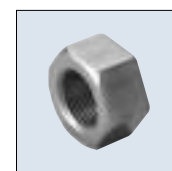

1M12

Basic load ratings		Track load capacity		Limiting speed	Maximum tightening torque	Mass	Stud dia.
dynamic	static	トラック負荷容量					
基本動 定格荷重	N kgf	基本静 定格荷重	N kgf	許容回転速度 r/min	締付最大トルク N·m	質量 kg	スタッド径
C_r	C_{or}	Spherical outer ring 球面外輪	Cylindrical outer ring 円筒外輪	Grease lubrication グリース潤滑	kgf·m	(approx.) (参考)	mm
13 300 1 360	13 500 1 380	2 620 267	7 700 785	6 900	20 2	0.088	12
22 300 2 280	25 700 2 620	3 200 325	11 900 1 220	5 500	52 5.3	0.165	16
24 100 2 450	29 100 2 970	3 850 390	14 500 1 480	4 700	76 7.8	0.242	18
38 500 3 950	48 000 4 900	4 700 480	21 000 2 150	4 000	98 10	0.380	20
42 500 4 350	57 500 5 850	5 550 565	23 300 2 370	3 300	98 10	0.450	20
56 500 5 750	72 500 7 400	6 950 710	34 500 3 500	2 900	178 18	0.795	24
62 000 6 350	85 500 8 700	8 050 820	38 500 3 900	2 400	178 18	1.01	24
101 000 10 300	151 000 15 400	9 800 1 000	53 000 5 400	2 100	360 37	1.54	30
101 000 10 300	151 000 15 400	11 400 1 160	59 000 6 100	2 100	360 37	1.96	30
119 000 12 100	167 000 17 000	13 000 1 300	79 000 8 050	2 000	630 65	3.08	36
172 000 17 600	266 000 27 100	16 400 1 670	113 000 11 500	1 700	1 020 105	5.17	42
201 000 20 500	294 000 30 000	20 000 2 040	152 000 15 500	1 500	1 540 160	7.98	48
258 000 26 300	380 000 39 000	22 000 2 250	173 000 17 600	1 300	1 950 200	9.70	52
274 000 27 900	400 000 41 000	24 000 2 450	194 000 19 800	1 200	2 480 250	11.7	56
320 000 32 500	475 000 48 500	26 000 2 650	218 000 22 200	1 100	3 030 310	13.9	60
365 000 37 500	555 000 56 500	27 900 2 840	253 000 25 800	1 000	3 670 375	17.0	64