

Main Spindle Bearings

11. Angular Contact Ball Bearings for Axial Loads CONTENTS

| | |
|--|---------|
| 11. Angular Contact Ball Bearings for Axial Loads | 248~271 |
| ① Features and types | 248 |
| ② Standard cage types | 249 |
| ③ Bearing designations | 249 |
| ④ Accuracy of double-direction angular contact thrust ball bearings | 250 |
| ⑤ Accuracy of high-speed duplex angular contact ball bearings for axial loads | 251 |
| ⑥ Basic preload | 252 |
| ⑦ Shaft and housing fits | 253 |
| ⑧ Recommended lubrication specifications | 253 |
| ⑨ Angular contact ball bearings for axial loads HTA U type | 254 |
| ⑩ Dimension tables | |
| Double-direction angular contact thrust ball bearings | 256 |
| Angular contact ball bearings for axial loads | 260 |

11. Angular Contact Ball Bearings for Axial Loads

① Features and types

NTN provides a range of thrust bearings for the main spindles. This includes 5629 and 5620 series for high axial rigidity (contact angle 60°) and HTA U(A) series high-speed duplex angular contact ball bearings for axial loads with optimized internal design (contact angle

40°, 30°). These bearings are used in conjunction with NN30, NN49, or NNU49 series double-row cylindrical roller bearings (matched bearings must have the same bore and outside diameter).

Table 11.1 Types of angular contact ball bearings for axial loads

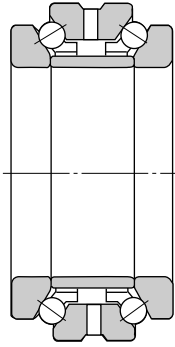
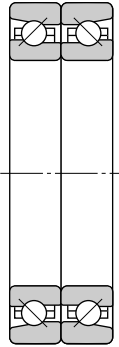
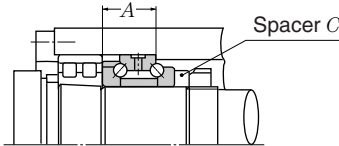
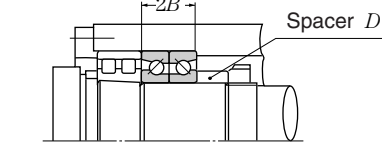
| | 5629 and 5620 series | HTA0U (A)..DB, HTA9U (A)..DB series |
|-----------------------|---|---|
| Bearing type |  |  |
| Initial contact angle | 60° | 40°, 30° |
| Cage material | High-strength machined brass cage | Molded resin, machined phenolic, high-strength machined copper alloy cage |
| Features | These series can withstand axial loads in both directions. Due to a larger contact angle, rigidity in axial directions is enhanced. The structure of these bearings limits them to grease-lubricated vertical shaft applications. | These duplex angular contact ball bearing series have similar design to the double-row thrust angular contact ball bearing series, but are different in terms of their widths (see the diagrams below). Since their contact angles are lower at 40° and 30°, the series boast high-speed capability. However, their axial rigidity is less than double-row thrust angular contact ball bearings with 60° contact angle. |
| Interchangeability | <p>A double-direction thrust angular contact ball bearing can be readily interchanged with a duplex angular contact ball bearing simply by replacing spacer C with spacer D; the dimensions of the shaft and housing remain unchanged.</p> <div style="display: flex; justify-content: space-around; align-items: center;"> <div style="text-align: center;">  <p>Double-direction thrust angular contact ball bearing</p> <p>5629 series 5620 series</p> </div> <div style="font-size: 2em; margin: 0 10px;">➔</div> <div style="text-align: center;"> <p>Dimension A = Dimension 2B</p>  <p>High-speed duplex angular contact ball bearing for axial loads</p> <p>HTA9UDB series HTB0UDB series</p> </div> </div> | |

② Standard cage types

Table 11.2 Standard cage of angular contact ball bearing for axial loads

| Bearing series | Machined phenol cage | Machined brass cage |
|----------------|----------------------|---------------------|
| 5629 | — | 562920~562964 |
| 5620 | — | 562005~562064 |
| HTA9U (A) | HTA920~HTA938U | HTA940U~HTA964U |
| HTA0U (A) | HTA007~HTA038U | HTA040U~HTA064U |

Notes: Cage types may be subjected to change without notice. For details, contact NTN Engineering.

③ Bearing designations

562 0 20M / GN P4

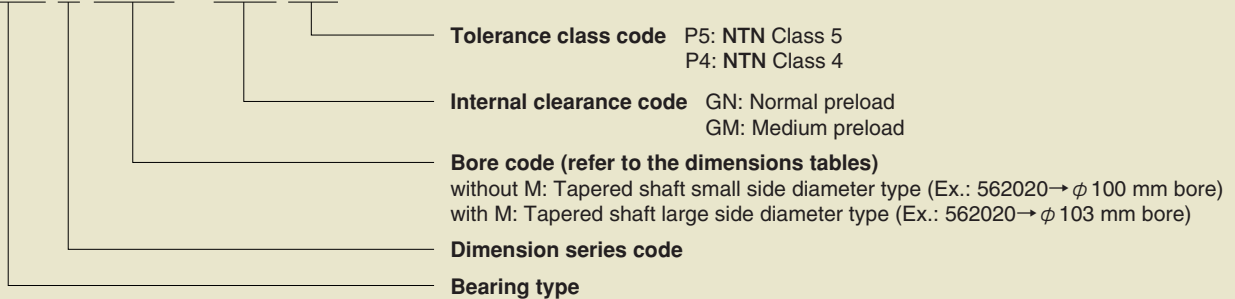

5S - HTA 0 20 U A T2 DB / GN P4L

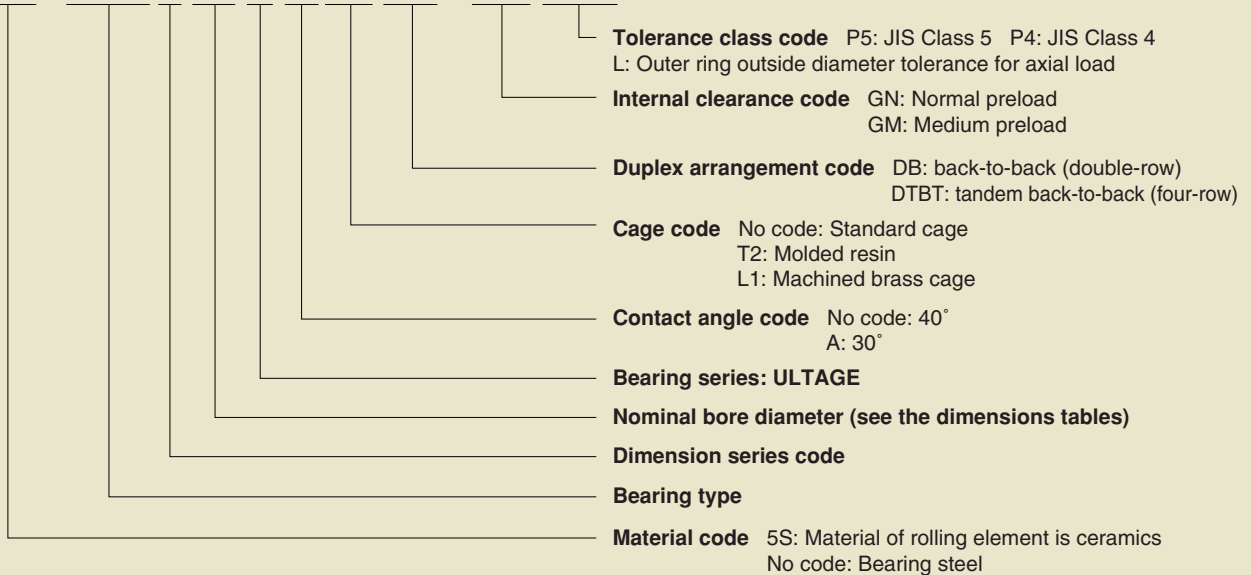

④ Accuracy of double-direction angular contact thrust ball bearings

Table 11.3 Inner rings

Unit: μm

| Nominal bore diameter d | | Single plane mean bore diameter deviation Δd_{mp} or bore diameter deviation Δd_s | | | | Perpendicularity of inner ring face with respect to the bore S_d | | Axial runout S_{ia} | | Width variation VB_s | | Bearing height deviation ΔT_s | |
|---------------------------|-------|---|-----|---|-----|--|-------------|-----------------------|-------------|------------------------|-------------|---------------------------------------|-------------|
| | | | | | | | | | | | | | |
| mm over | incl. | | | | | Class 5 max | Class 4 max | Class 5 max | Class 4 max | Class 5 max | Class 4 max | Class 5 high | Class 4 low |
| 18 | 30 | 0 | -6 | 0 | -5 | 8 | 4 | 5 | 3 | 5 | 2.5 | 0 | -300 |
| 30 | 50 | 0 | -8 | 0 | -6 | 8 | 4 | 5 | 3 | 5 | 3 | 0 | -400 |
| 50 | 80 | 0 | -9 | 0 | -7 | 8 | 5 | 6 | 5 | 6 | 4 | 0 | -500 |
| 80 | 120 | 0 | -10 | 0 | -8 | 9 | 5 | 6 | 5 | 7 | 4 | 0 | -600 |
| 120 | 180 | 0 | -13 | 0 | -10 | 10 | 6 | 8 | 6 | 8 | 5 | 0 | -700 |
| 180 | 250 | 0 | -15 | 0 | -12 | 11 | 7 | 8 | 6 | 10 | 6 | 0 | -800 |
| 250 | 315 | 0 | -18 | 0 | -15 | 13 | 8 | 10 | 8 | 13 | 7 | 0 | -900 |
| 315 | 400 | 0 | -23 | 0 | -18 | 15 | 9 | 13 | 10 | 15 | 9 | 0 | -1000 |

Table 11.4 Outer rings

Unit: μm

| Nominal bore diameter D | | Single plane mean outside diameter deviation ΔD_{mp} or outside diameter deviation ΔD_s | | Perpendicularity of outer ring outside surface with respect to the face S_D | | Axial runout S_{ea} | | Width variation VC_s | |
|---------------------------|-------|---|------|---|-------------|---|-------------|------------------------|-------------|
| | | | | | | | | | |
| mm over | incl. | | | Class 5 max | Class 4 max | Class 5 max | Class 4 max | Class 5 max | Class 4 max |
| 30 | 50 | -30 | -40 | 8 | 4 | Identical to $\square B_s$ relative to d of the same bearing. | | 5 | 2.5 |
| 50 | 80 | -40 | -50 | 8 | 4 | | 6 | 3 | |
| 80 | 120 | -50 | -60 | 9 | 5 | | 8 | 4 | |
| 120 | 150 | -60 | -75 | 10 | 5 | | 8 | 5 | |
| 150 | 180 | -60 | -75 | 10 | 5 | | 8 | 5 | |
| 180 | 250 | -75 | -90 | 11 | 7 | | 10 | 7 | |
| 250 | 315 | -90 | -105 | 13 | 8 | | 11 | 7 | |
| 315 | 400 | -110 | -125 | 13 | 10 | | 13 | 8 | |
| 400 | 500 | -120 | -140 | 15 | 13 | 15 | 10 | | |

⑤ Accuracy of high-speed duplex angular contact ball bearings for axial loads

Table 11.5 Inner rings

Unit: μm

| Nominal bore diameter d | | Single plane mean bore diameter deviation Δd_{mp} | | | | Single radial plane bore diameter variation V_{dsp} | | | | Mean bore diameter deviation V_{dmp} | | Perpendicularity of inner ring face with respect to the bore S_d | | Axial runout | |
|------------------------------|-----|--|-------|--------------|--------------------------|--|-------------------------------|-------------------------------|-------------------------------|---|-------------|---|-------------|--------------|-------------|
| | | | | | | | | | | | | | | S_{ia} | |
| | | mm over | incl. | Class 5 high | Class 4 ^① low | Diameter series 9 Class 5 max | Diameter series 9 Class 4 max | Diameter series 0 Class 5 max | Diameter series 0 Class 4 max | Class 5 max | Class 4 max | Class 5 max | Class 4 max | Class 5 max | Class 4 max |
| 18 | 30 | 0 | -6 | 0 | -5 | 6 | 5 | 5 | 4 | 3 | 2.5 | 8 | 4 | 5 | 3 |
| 30 | 50 | 0 | -8 | 0 | -6 | 8 | 6 | 6 | 5 | 4 | 3 | 8 | 4 | 5 | 3 |
| 50 | 80 | 0 | -9 | 0 | -7 | 9 | 7 | 7 | 5 | 5 | 3.5 | 8 | 5 | 6 | 5 |
| 80 | 120 | 0 | -10 | 0 | -8 | 10 | 8 | 8 | 6 | 5 | 4 | 9 | 5 | 6 | 5 |
| 120 | 150 | 0 | -13 | 0 | -10 | 13 | 10 | 10 | 8 | 7 | 5 | 10 | 6 | 8 | 6 |
| 150 | 180 | 0 | -13 | 0 | -10 | 13 | 10 | 10 | 8 | 7 | 5 | 10 | 6 | 8 | 6 |
| 180 | 250 | 0 | -15 | 0 | -12 | 15 | 12 | 12 | 9 | 8 | 6 | 11 | 7 | 8 | 6 |
| 250 | 315 | 0 | -18 | 0 | -14 | 18 | 14 | 14 | 11 | 9 | 8 | 13 | 8 | 10 | 8 |
| 315 | 400 | 0 | -23 | 0 | -16 | 23 | 17 | 18 | 12 | 12 | 9 | 15 | 10 | 13 | 10 |

Unit: μm

| Overall width variation of assembled bearing ΔB_s | | Width variation VB_s | | Nominal bore diameter d | |
|--|------|---------------------------|-----|------------------------------|-----|
| | | | | | |
| 0 | -240 | 5 | 2.5 | 18 | 30 |
| 0 | -240 | 5 | 3 | 30 | 50 |
| 0 | -300 | 6 | 4 | 50 | 80 |
| 0 | -400 | 7 | 4 | 80 | 120 |
| 0 | -500 | 8 | 5 | 120 | 150 |
| 0 | -500 | 8 | 5 | 150 | 180 |
| 0 | -600 | 10 | 6 | 180 | 250 |
| 0 | -700 | 13 | 8 | 250 | 315 |
| 0 | -800 | 15 | 10 | 315 | 400 |

① The tolerance of bore diameter deviation Δd_s is the same as the tolerance of single plane mean bore diameter deviation Δd_{mp} .

Table 11.6 Outer rings

Unit: μm

| Nominal bore diameter D | | Single plane mean outside diameter deviation ΔD_{mp} and outside diameter deviation ΔD_s | | | | | | Axial runout S_{ea} | | Overall width variation of assembled bearing ΔC_s | | Width variation | |
|------------------------------|-----|---|-------|--|---------------------------------------|--------------|-------------|---------------------------|--------------------------|--|---------------------|-----------------|-------------|
| | | | | | | | | | | | | VC_s | |
| | | mm over | incl. | Class 5L or Class 4L ^② high | Class 5L or Class 4L ^② low | Class 5 high | Class 5 low | Class 4 ^② high | Class 4 ^② low | Class 5 All classes | Class 4 All classes | Class 5 max | Class 4 max |
| 30 | 50 | -25 | -36 | 0 | -7 | 0 | -6 | 8 | 5 | Identical to B_s relative to d on the same bearing. | 5 | 2.5 | |
| 50 | 80 | -30 | -43 | 0 | -9 | 0 | -7 | 10 | 5 | | 6 | 3 | |
| 80 | 120 | -36 | -51 | 0 | -10 | 0 | -8 | 11 | 6 | | 8 | 4 | |
| 120 | 150 | -43 | -61 | 0 | -11 | 0 | -9 | 13 | 7 | | 8 | 5 | |
| 150 | 180 | -43 | -61 | 0 | -13 | 0 | -10 | 14 | 8 | | 8 | 5 | |
| 180 | 250 | -50 | -70 | 0 | -15 | 0 | -11 | 15 | 10 | | 10 | 7 | |
| 250 | 315 | -56 | -79 | 0 | -18 | 0 | -13 | 18 | 10 | | 11 | 7 | |
| 315 | 400 | -62 | -87 | 0 | -20 | 0 | -15 | 20 | 13 | | 13 | 8 | |
| 400 | 500 | -68 | -95 | 0 | -23 | - | - | 23 | 15 | 15 | 10 | | |

② The tolerance of outside diameter deviation ΔD_s to be applied to the Class 4 and Class 2 is same as the tolerance of the mean outside diameter deviation Δd_{mp} . Note that the Class 4 is applicable to diameter series 0 and 2, and the Class 2 is applicable to all the diameter series.
Note: This standard is the NTN standard.

⑥ Basic preload

The initial internal clearance or initial preload must be selected with consideration of the lubricating method, maximum speed, and required axial rigidity. Although usage with normal preload (GN) within the allowable speed range is possible for both grease lubrication and

air-oil lubrication, ask NTN Engineering to recommend the appropriate preload if axial rigidity is required and you want to inhibit temperature rise of the main spindle. The standard preloads are summarized in **Table 11.7**.

Table 11.7 Basic preload

Unit : N {kgf}

| Bore number | 5629 | | 5620 | | HTA9UDB | | HTA9UADB | | HTA0UDB | | HTA0UADB | | Bore number |
|-------------|-----------------|-----------------|-----------------|-----------------|-----------------|-------------------|-----------------|-----------------|-------------------|-------------------|-----------------|-------------------|-------------|
| | Normal GN GN | Medium GM GM | Normal GN GN | Medium GM GM | Normal GN GN | Medium GM GM | Normal GN GN | Medium GM GM | Normal GN GN | Medium GM GM | Normal GN GN | Medium GM GM | |
| 05 | | | 294 {30} | 685 {70} | | | | | 390 {40} | 685 {70} | 147 {15} | 294 {30} | 05 |
| 06 | | | | | | | | | | | | | 06 |
| 07 | | | 490 {50} | 785 {80} | | | | | | | | | 07 |
| 08 | | | | | | | | | | | 294 {30} | 590 {60} | 08 |
| 09 | | | | | | | | | | | | | 09 |
| 10 | | | | | | | | | 685 {70} | 1 270 {130} | | | 10 |
| 11 | | | 980 {100} | 1 670 {170} | | | | | | | 490 {50} | 885 {90} | 11 |
| 12 | — | — | | | — | — | — | — | | | | | 12 |
| 13 | | | | | | | | | | | | | 13 |
| 14 | | | | | | | | | | | | | 14 |
| 15 | | | | | | | | | 980 {100} | 1 570 {160} | 590 {60} | 1 470 {150} | 15 |
| 16 | | | 1 470 {150} | 2 450 {250} | | | | | | 1 960 {200} | | | 16 |
| 17 | | | | | | | | | | | | | 17 |
| 18 | | | | | | | | | | | 885 {90} | 1 960 {200} | 18 |
| 19 | | | | | | | | | 1 470 {150} | 2 450 {250} | | | 19 |
| 20 | | | | | | | | | | | | | 20 |
| 21 | 1 470 {150} | 2 450 {250} | | | 980 {100} | 1 670 {170} | 685 {70} | 1 270 {130} | | | | | 21 |
| 22 | | | | | | | | | 1 960 {200} | 3 450 {350} | 980 {100} | 2 450 {250} | 22 |
| 24 | | | | | | | | 885 {90} | 1 770 {180} | | | | 24 |
| 26 | | | 1 960 {200} | 3 250 {330} | 1 270 {130} | 2 450 {250} | 980 {100} | 1 960 {200} | | | | | 26 |
| 28 | 1 960 {200} | 2 940 {300} | | | | | | | 2 940 {300} | 5 400 {550} | 1 470 {150} | 3 450 {350} | 28 |
| 30 | | | | | | | | | | | | | 30 |
| 32 | | | | | 1 960 {200} | 3 450 {350} | 1 270 {130} | 2 450 {250} | | | | | 32 |
| 34 | | | | | | | | | 3 900 {400} | 7 350 {750} | 2 450 {250} | 4 900 {500} | 34 |
| 36 | | | | | | | | | | | | | 36 |
| 38 | 2 450 {250} | 3 900 {400} | 2 450 {250} | 3 900 {400} | 3 450 {350} | 5 900 {600} | 1 770 {180} | 3 450 {350} | 4 900 {500} | 9 300 {950} | 3 450 {350} | 6 850 {700} | 38 |
| 40 | | | | | | | | 2 450 {250} | 4 900 {500} | | | | 40 |
| 44 | 2 940 {300} | 4 400 {450} | | | 3 900 {400} | 6 850 {700} | | | | | | | 44 |
| 48 | | | 2 940 {300} | 4 400 {450} | | | | | 6 850 {700} | 12 700 {1 300} | 3 900 {400} | 7 850 {800} | 48 |
| 52 | | | | | | | | | | | | | 52 |
| 56 | 3 900 {400} | 5 900 {600} | | | 4 900 {500} | 8 850 {900} | | | 8 850 {900} | 15 700 {1 600} | | | 56 |
| 60 | | | 3 900 {400} | 5 900 {600} | 5 900 {600} | 11 800 {1 200} | | | | | 5 900 {600} | 11 800 {1 200} | 60 |
| 64 | 4 900 {500} | 7 350 {750} | | | | | | | 10 800 {1 100} | 17 700 {1 800} | | | 64 |

⑦ Shaft and housing fits

Fits given in **Table 11.8** are recommended for angular contact ball bearings for axial loads. To maintain high accuracy, provision of interference between the shaft and the bore of inner ring is essential. The fit of the housing and bearing should be same as that for cylindrical roller bearings, since an angular contact ball bearing is normally used together with a cylindrical roller bearing.

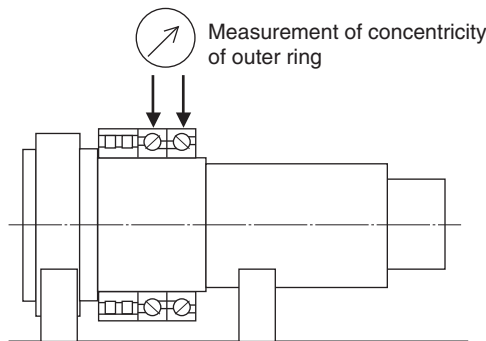

Fig. 11.1 Concentricity

■ Checking concentricity of outside diameter of outer ring after bearing

Controlling concentricity of outer ring assembly is necessary for reduction of axial runout of the main spindle. Measure and control the concentricity of outer ring shown in **Fig. 11.1** and "6. Handling of Bearings, ② Mounting" in the Technical Data section.

Table 11.8 Fit to shaft Unit: μm

| Nominal bore diameter d mm | | Fit of inner ring to shaft |
|---------------------------------|-------|-------------------------------|
| over | incl. | |
| 2.5 | 10 | 0~2T |
| 10 | 18 | 0~2T |
| 18 | 30 | 0~2.5T |
| 30 | 50 | 0~3T |
| 50 | 80 | 0~3.5T |
| 80 | 120 | 0~4T |
| 120 | 180 | 0~5T |
| 180 | 250 | 0~6T |

Note 1: Target the median value.

2: For high-speed applications where d_{min} value exceeds 0.75×10^6 , the fit should be increased. For such an arrangement, consult NTN Engineering.

T: Tight (Interference) fit

⑧ Recommended lubrication specifications

Angular contact ball bearings for axial loads are usually used with grease lubrication or air-oil lubrication. Recommended specifications of the lubrication methods are described below.

■ Grease lubrication

● Recommended brand of grease

Refer to "7. Lubrication of Bearings, ① Grease lubrication" in the Technical Data section.

● Recommended grease filling amount

d_{min} value $\leq 0.65 \times 10^6$

15% of the capacity shown in the dimensions tables

d_{min} value $> 0.65 \times 10^6$

12% of the capacity shown in the dimensions tables

● Recommended grease filling method

Refer to "6. Handling of Bearings, ① Cleaning and filling with grease" in the Technical Data section.

Notes: High-strength machined brass cages are used for 5629/5620 series. Thus, if they are used for grease-lubricated vertical shafts, the cage on one side may hang onto the rolling elements, possibly causing seizure. Use of the HTA series with resin cages or oil lubrication (including feeding of lubricating oil) is recommended.

■ Air-oil lubrication

● Recommended location of nozzle

Refer to "7. Lubrication of Bearings ②

Recommended location of nozzle for air-oil lubrication" in the Technical Data section.

● Recommended specifications of nozzle

Nozzle bore diameter : From 1 to 1.5 mm

Number of nozzles: One nozzle for each bearing, depth of nozzle bore should be four to six times of nozzle bore diameter.

● Recommended specifications of air-oil

Oil type: Spindle oil

Viscosity grade: ISO VG from 10 to 32 (32 is preferable)

Table 11.9 Air and oil amount

| Bearing types | d_{min} value ($\times 10^6$) | | Oil amount per shot mL | Lubrication intervals min | Oil consumption mL/h | Recommended air consumption *NL/min |
|---------------|--|-------|------------------------------|---------------------------------|----------------------------|---|
| | Over | Incl. | | | | |
| HTA9 (A) | ~ 1.0 | | 0.03 | 8 | 0.23 | 20~40 |
| HTA0 (A) | 1.0 ~ 1.2 | | | 5 | 0.36 | |
| 5S-HTA0 (A) | | | | | | |

* NL/min (Normal liter/minute) ... NL means the volume of air at 0°C and 1 atmosphere.

⑨ Angular contact ball bearings for axial loads HTA U type

HTA U type angular contact ball bearing has a higher limiting speed with the same rigidity and loading capability as the conventional HTA series.

■ Features

1. Optimized internal design to minimize the temperature rise especially at high speed range.
2. Improved molded nylon cage pocket design where the ball contacts to have higher lubrication performance under grease or air-oil lubrication.

■ Bearings design

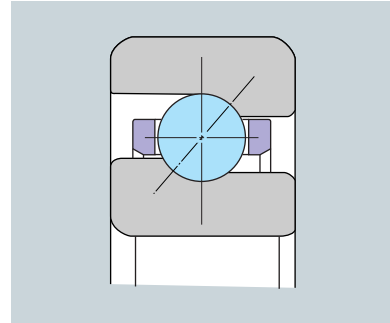
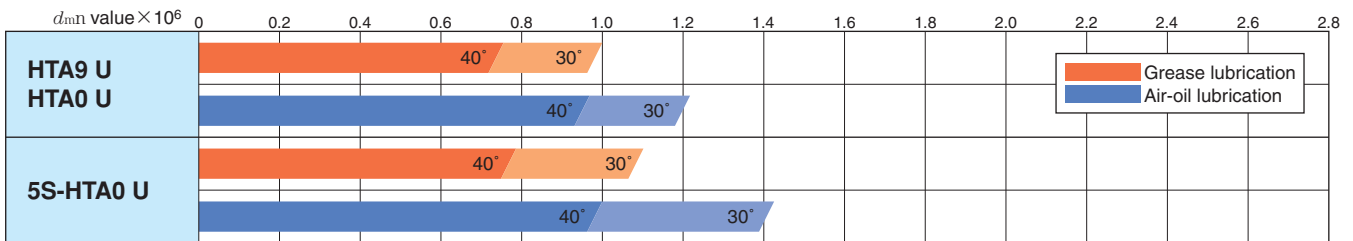

Fig. 11.2 HTA U type

■ Permissible speed range



Notes) Permissible speed of each bearing (d_{m1} value) varies depending on the specifications of the machine for which the bearing is used (motor drive system, cooling system, and construction around the bearing). Consider the optimal choice referring to the above guideline and contact NTN.

■ Axial rigidity

Axial rigidity is at the same level as the conventional design.

■ Data/Allowable axial load

By reviewing the internal structure, the allowable axial load has improved over HTA types by about 1.3 times with the contact angle of 30° and by about 1.2 times with the contact angle of 40°.

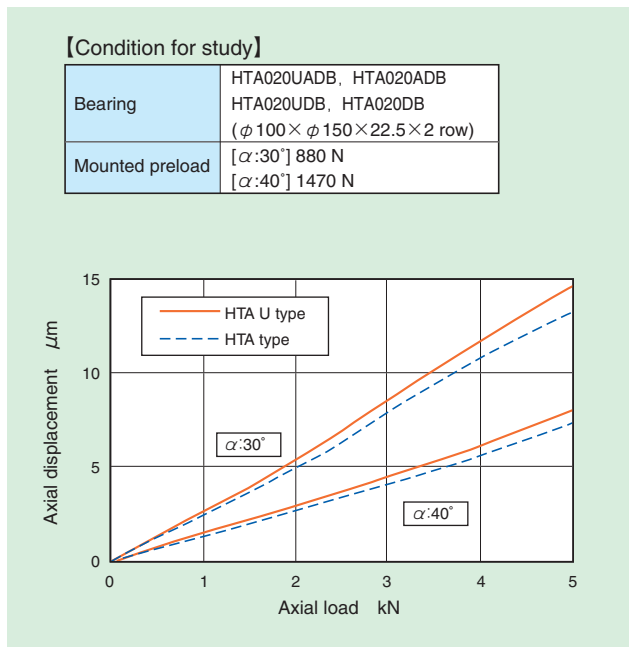

Fig. 11.3 Axial load and rigidity

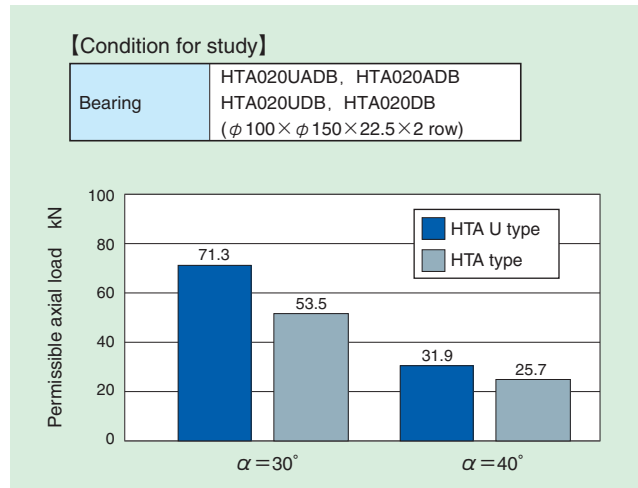

Fig. 11.4 Comparison of permissible axial load

High speed test

d_{mn} value of 1.0 million under grease lubrication and 1.25 million under air-oil lubrication are realized by the optimized internal design. (Fig.11.5~11.8)

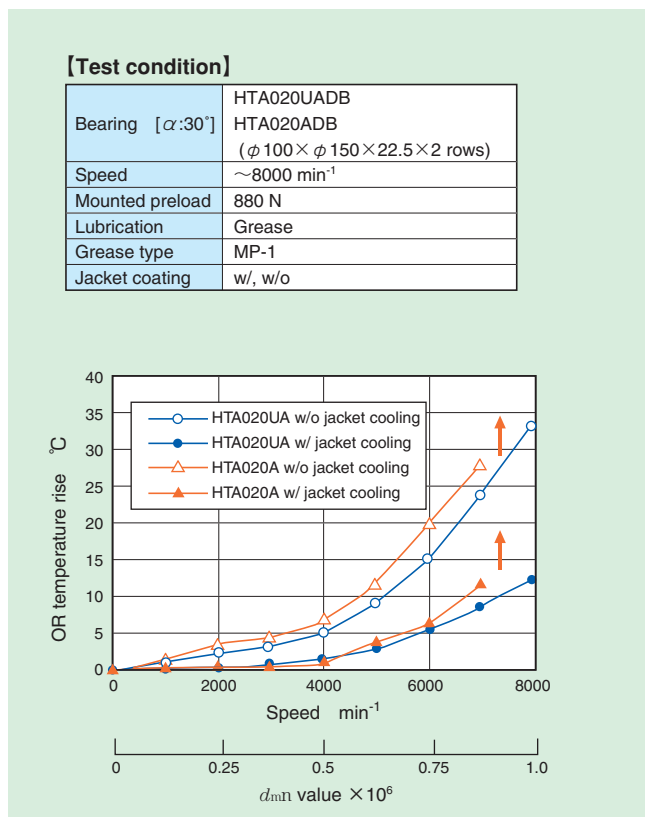

Fig. 11.5 Comparison of temperature rise (Grease, $\alpha = 30^\circ$)

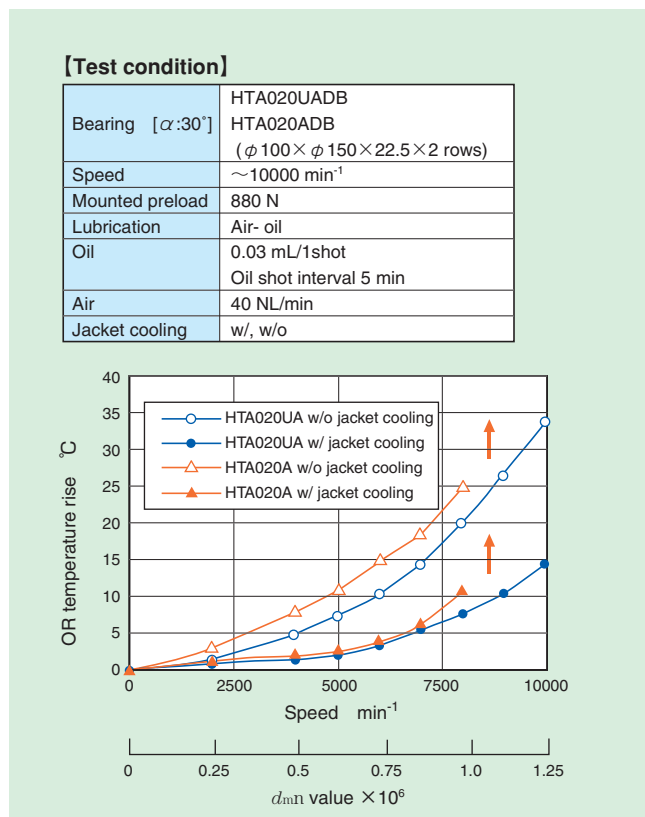

Fig. 11.6 Comparison of temperature rise (Air-oil, $\alpha = 30^\circ$)

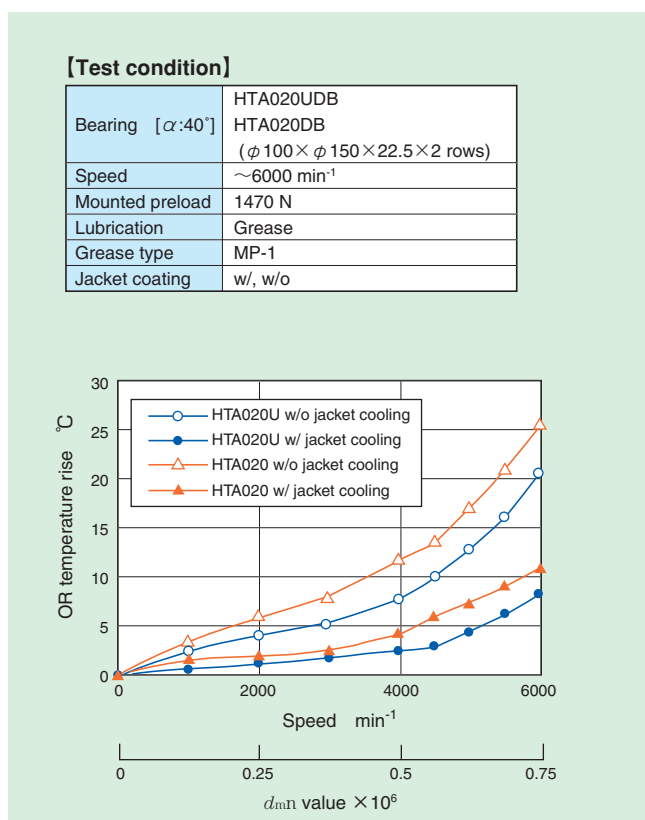

Fig. 11.7 Comparison of temperature rise (Grease, $\alpha = 40^\circ$)

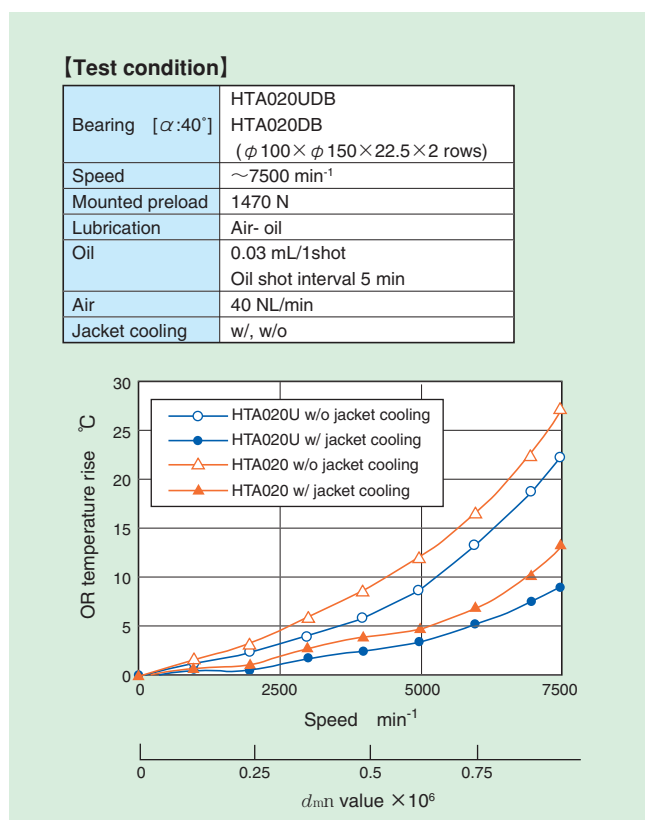
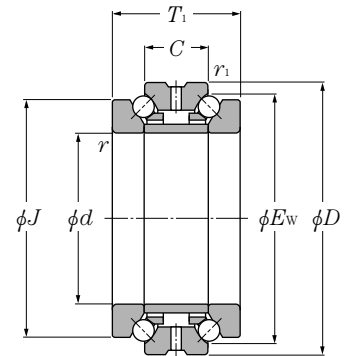

Fig. 11.8 Comparison of temperature rise (Air-oil, $\alpha = 40^\circ$)

⑩ Dimension tables for angular contact ball bearings

Double-direction angular contact thrust ball bearings 5629 series

Contact angle 60° d 100~320mm



| Part number | | Boundary dimensions | | | | | | | | Basic load ratings | | | | Limiting speed | | Mass | |
|-------------|------------|---------------------|------------|-----|-------|-----|-----|------------------------|---------------------------|--------------------|--------|---------|--------|--------------------|-----------------|------------|------------|
| small size | large size | d | | mm | | | | r_s min ^① | r_{1s} min ^① | dynamic | static | dynamic | static | grease lubrication | oil lubrication | small size | large size |
| | | small size | large size | D | T_1 | C | kN | | | kN | kgf | kN | kN | | | | |
| 562920 | 562920M | 100 | 104 | 140 | 48 | 24 | 1.1 | 0.6 | 52.0 | 179 | 5 300 | 18 200 | 3 200 | 4 200 | 2.04 | 1.8 | |
| 562921 | 562921M | 105 | 109 | 145 | 48 | 24 | 1.1 | 0.6 | 53.5 | 188 | 5 450 | 19 200 | 3 000 | 4 100 | 2.12 | 1.87 | |
| 562922 | 562922M | 110 | 114 | 150 | 48 | 24 | 1.1 | 0.6 | 54.0 | 193 | 5 500 | 19 700 | 2 900 | 3 900 | 2.21 | 1.95 | |
| 562924 | 562924M | 120 | 124 | 165 | 54 | 27 | 1.1 | 0.6 | 65.0 | 242 | 6 600 | 24 700 | 2 600 | 3 500 | 3.06 | 2.75 | |
| 562926 | 562926M | 130 | 134 | 180 | 60 | 30 | 1.5 | 1 | 75.0 | 284 | 7 650 | 28 900 | 2 400 | 3 200 | 4.11 | 3.7 | |
| 562928 | 562928M | 140 | 144 | 190 | 60 | 30 | 1.5 | 1 | 76.0 | 297 | 7 750 | 30 500 | 2 300 | 3 100 | 4.38 | 3.94 | |
| 562930 | 562930M | 150 | 155 | 210 | 72 | 36 | 2 | 1 | 107 | 410 | 10 900 | 41 500 | 2 100 | 2 800 | 6.88 | 6.2 | |
| 562932 | 562932M | 160 | 165 | 220 | 72 | 36 | 2 | 1 | 109 | 430 | 11 100 | 44 000 | 2 000 | 2 600 | 7.26 | 6.53 | |
| 562934 | 562934M | 170 | 175 | 230 | 72 | 36 | 2 | 1 | 111 | 450 | 11 300 | 46 000 | 1 900 | 2 500 | 7.64 | 6.88 | |
| 562936 | 562936M | 180 | 186 | 250 | 84 | 42 | 2 | 1 | 156 | 605 | 15 900 | 62 000 | 1 700 | 2 300 | 11.2 | 10 | |
| 562938 | 562938M | 190 | 196 | 260 | 84 | 42 | 2 | 1 | 157 | 625 | 16 000 | 63 500 | 1 700 | 2 200 | 11.7 | 10.5 | |
| 562940 | 562940M | 200 | 207 | 280 | 96 | 48 | 2.1 | 1.1 | 185 | 735 | 18 800 | 75 000 | 1 600 | 2 100 | 16.3 | 14.7 | |
| 562944 | 562944M | 220 | 227 | 300 | 96 | 48 | 2.1 | 1.1 | 190 | 795 | 19 400 | 81 000 | 1 400 | 1 900 | 17.7 | 16 | |
| 562948 | 562948M | 240 | 247 | 320 | 96 | 48 | 2.1 | 1.1 | 196 | 850 | 20 000 | 87 000 | 1 300 | 1 800 | 19 | 17 | |
| 562952 | 562952M | 260 | 269 | 360 | 120 | 60 | 2.1 | 1.1 | 261 | 1 130 | 26 600 | 116 000 | 1 200 | 1 600 | 32.9 | 29.6 | |
| 562956 | 562956M | 280 | 289 | 380 | 120 | 60 | 2.1 | 1.1 | 265 | 1 190 | 27 000 | 121 000 | 1 100 | 1 500 | 35 | 31.5 | |
| 562960 | 562960M | 300 | 310 | 420 | 144 | 72 | 3 | 1.1 | 335 | 1 510 | 34 500 | 154 000 | 1 000 | 1 400 | 55 | 49.5 | |
| 562964 | 562964M | 320 | 330 | 440 | 144 | 72 | 3 | 1.1 | 340 | 1 580 | 3 500 | 161 000 | 1 000 | 1 300 | 58.1 | 52.3 | |

① Minimum allowable value for corner radius dimension r or r_1 .

② Maximum circumscribed circle diameter of balls.

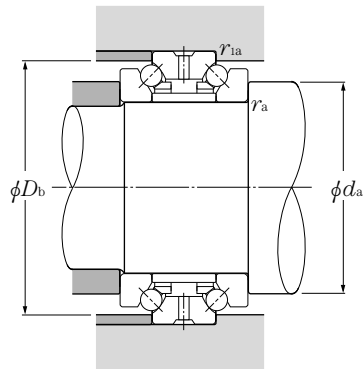

Dynamic equivalent axial load

$$P_a = F_a$$

Static equivalent axial load

$$P_{0a} = F_a$$

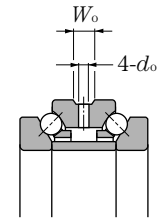

Dimensions of oil hole and oil groove

unit: mm

| Reference dimensions mm | | Abutment and fillet dimensions mm | | | | Part number | |
|----------------------------|-----------------------------------|--------------------------------------|-----------------------------|------------------------------|-------------------------------|-------------|------------|
| <i>J</i> | <i>E_w</i> ^② | <i>d_a</i> min | <i>D_b</i> max | <i>r_{as}</i> max | <i>r_{1as}</i> max | small size | large size |
| 126 | 129 | 114 | 134.5 | 1 | 0.6 | 562920 | 562920M |
| 131 | 134 | 119 | 139.5 | 1 | 0.6 | 562921 | 562921M |
| 136 | 139 | 124 | 144.5 | 1 | 0.6 | 562922 | 562922M |
| 150 | 154.5 | 138 | 159.5 | 1 | 0.6 | 562924 | 562924M |
| 163 | 168 | 150 | 173.5 | 1.5 | 1 | 562926 | 562926M |
| 173 | 178 | 160 | 183.5 | 1.5 | 1 | 562928 | 562928M |
| 190 | 196.5 | 174 | 202 | 2 | 1 | 562930 | 562930M |
| 200 | 206.5 | 184 | 212 | 2 | 1 | 562932 | 562932M |
| 210 | 216.5 | 194 | 222 | 2 | 1 | 562934 | 562934M |
| 227 | 234 | 207 | 242 | 2 | 1 | 562936 | 562936M |
| 237 | 344 | 217 | 252 | 2 | 1 | 562938 | 562938M |
| 252 | 261 | 231 | 270 | 2 | 1 | 562940 | 562940M |
| 272 | 281 | 251 | 290 | 2 | 1 | 562944 | 562944M |
| 292 | 301 | 271 | 310 | 2 | 1 | 562948 | 562948M |
| 328 | 336 | 299 | 350 | 2 | 1 | 562952 | 562952M |
| 348 | 356 | 319 | 370 | 2 | 1 | 562956 | 562956M |
| 384 | 391 | 349 | 410 | 2.5 | 1 | 562960 | 562960M |
| 404 | 411 | 369 | 430 | 2.5 | 1 | 562964 | 562964M |

| Nominal outer diameter <i>D</i> | | Oil groove width <i>W_o</i> | Oil hole diameter <i>d_o</i> |
|------------------------------------|-------|--|---|
| over | incl. | | |
| 150 | 200 | 8 | 4 |
| 200 | 210 | 12 | 6 |
| 210 | 260 | 12 | 6 |
| 260 | 320 | 14 | 6 |

Double-direction angular contact thrust ball bearings 5620 series

Contact angle 60° d 25~320mm

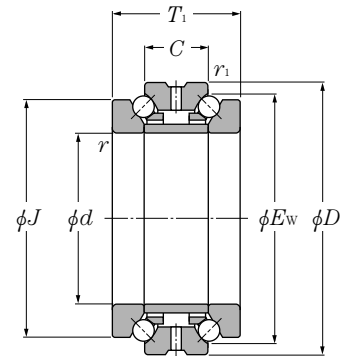

| Part number | | Boundary dimensions | | | | | | | Basic load ratings | | | | Limiting speed | | Mass (approx.) | |
|-------------|------------|---------------------|------------|-----|-------|-----|------------------------------|---------------------------------|--------------------|----------|---------|----------|--------------------|-----------------|----------------|------------|
| small size | large size | d | | mm | | | | | dynamic | static | dynamic | static | grease lubrication | oil lubrication | small size | large size |
| | | small size | large size | D | T_1 | C | $r_s \text{ min}^{\text{①}}$ | $r_{1s} \text{ min}^{\text{②}}$ | C_a | C_{oa} | C_a | C_{oa} | | | | |
| 562005 | 562005M | 25 | 27 | 47 | 28 | 14 | 0.6 | 0.3 | 13.2 | 28.3 | 1 350 | 2 890 | 10 400 | 14 000 | 0.197 | 0.177 |
| 562006 | 562006M | 30 | 32 | 55 | 32 | 16 | 1 | 0.6 | 14.0 | 32.5 | 1 420 | 3 350 | 8 700 | 11 700 | 0.301 | 0.28 |
| 562007 | 562007M | 35 | 37 | 62 | 34 | 17 | 1 | 0.6 | 19.7 | 48.5 | 2 010 | 4 950 | 7 700 | 10 300 | 0.394 | 0.35 |
| 562008 | 562008M | 40 | 42 | 68 | 36 | 18 | 1 | 0.6 | 23.8 | 58.5 | 2 430 | 5 950 | 7 000 | 9 400 | 0.482 | 0.44 |
| 562009 | 562009M | 45 | 47 | 75 | 38 | 19 | 1 | 0.6 | 26.0 | 69.0 | 2 650 | 7 000 | 6 200 | 8 300 | 0.605 | 0.54 |
| 562010 | 562010M | 50 | 52 | 80 | 38 | 19 | 1 | 0.6 | 26.8 | 74.0 | 2 730 | 7 550 | 5 700 | 7 700 | 0.638 | 0.59 |
| 562011 | 562011M | 55 | 57 | 90 | 44 | 22 | 1.1 | 0.6 | 37.0 | 99.0 | 3 800 | 10 100 | 5 200 | 7 000 | 0.988 | 0.9 |
| 562012 | 562012M | 60 | 62 | 95 | 44 | 22 | 1.1 | 0.6 | 37.5 | 103 | 3 850 | 10 500 | 4 900 | 6 500 | 1.06 | 0.96 |
| 562013 | 562013M | 65 | 67 | 100 | 44 | 22 | 1.1 | 0.6 | 39.0 | 111 | 3 950 | 11 300 | 4 600 | 6 100 | 1.08 | 1 |
| 562014 | 562014M | 70 | 73 | 110 | 48 | 24 | 1.1 | 0.6 | 47.5 | 140 | 4 850 | 14 300 | 4 200 | 5 600 | 1.53 | 1.4 |
| 562015 | 562015M | 75 | 78 | 115 | 48 | 24 | 1.1 | 0.6 | 49.0 | 150 | 5 000 | 15 300 | 3 900 | 5 300 | 1.61 | 1.5 |
| 562016 | 562016M | 80 | 83 | 125 | 54 | 27 | 1.1 | 0.6 | 57.5 | 178 | 5 850 | 18 200 | 3 700 | 4 900 | 2.2 | 2 |
| 562017 | 562017M | 85 | 88 | 130 | 54 | 27 | 1.1 | 0.6 | 58.0 | 184 | 5 950 | 18 800 | 3 500 | 4 700 | 2.31 | 2.1 |
| 562018 | 562018M | 90 | 93 | 140 | 60 | 30 | 1.5 | 1 | 67.5 | 216 | 6 850 | 22 000 | 3 300 | 4 400 | 3.05 | 2.7 |
| 562019 | 562019M | 95 | 98 | 145 | 60 | 30 | 1.5 | 1 | 68.0 | 223 | 6 950 | 22 700 | 3 100 | 4 200 | 3.18 | 2.9 |
| 562020 | 562020M | 100 | 104 | 150 | 60 | 30 | 1.5 | 1 | 68.5 | 229 | 7 000 | 23 400 | 3 000 | 4 000 | 3.32 | 3 |
| 562021 | 562021M | 105 | 109 | 160 | 66 | 33 | 2 | 1 | 78.5 | 266 | 8 000 | 27 100 | 2 800 | 3 800 | 4.19 | 3.7 |
| 562022 | 562022M | 110 | 114 | 170 | 72 | 36 | 2 | 1 | 96.0 | 315 | 9 750 | 32 500 | 2 700 | 3 600 | 5.35 | 4.9 |
| 562024 | 562024M | 120 | 124 | 180 | 72 | 36 | 2 | 1 | 98.0 | 335 | 10 000 | 34 500 | 2 500 | 3 300 | 5.73 | 5.2 |
| 562026 | 562026M | 130 | 134 | 200 | 84 | 42 | 2 | 1 | 139 | 460 | 14 200 | 47 000 | 2 300 | 3 100 | 8.58 | 7.6 |
| 562028 | 562028M | 140 | 144 | 210 | 84 | 42 | 2 | 1 | 144 | 495 | 14 600 | 50 500 | 2 200 | 2 900 | 9.1 | 8.1 |
| 562030 | 562030M | 150 | 155 | 225 | 90 | 45 | 2.1 | 1.1 | 147 | 525 | 15 000 | 53 500 | 2 000 | 2 700 | 11.2 | 10 |
| 562032 | 562032M | 160 | 165 | 240 | 96 | 48 | 2.1 | 1.1 | 172 | 620 | 17 600 | 63 000 | 1 900 | 2 500 | 13.6 | 11.9 |
| 562034 | 562034M | 170 | 175 | 260 | 108 | 54 | 2.1 | 1.1 | 202 | 735 | 20 600 | 75 000 | 1 800 | 2 400 | 18.5 | 16.5 |
| 562036 | 562036M | 180 | 186 | 280 | 120 | 60 | 2.1 | 1.1 | 234 | 865 | 23 900 | 88 000 | 1 600 | 2 200 | 24.7 | 21.8 |
| 562038 | 562038M | 190 | 196 | 290 | 120 | 60 | 2.1 | 1.1 | 236 | 890 | 24 100 | 91 000 | 1 600 | 2 100 | 25.5 | 23 |
| 562040 | 562040M | 200 | 207 | 310 | 132 | 66 | 2.1 | 1.1 | 271 | 1 030 | 27 700 | 105 000 | 1 500 | 2 000 | 32.7 | 29.7 |
| 562044 | 562044M | 220 | 227 | 340 | 144 | 72 | 3 | 1.1 | 335 | 1 270 | 34 000 | 129 000 | 1 300 | 1 800 | 42.8 | 38.5 |
| 562048 | 562048M | 240 | 247 | 360 | 144 | 72 | 3 | 1.1 | 340 | 1 350 | 35 000 | 137 000 | 1 300 | 1 700 | 45.8 | 41.2 |
| 562052 | 562052M | 260 | 269 | 400 | 164 | 82 | 4 | 1.5 | 405 | 1 710 | 41 500 | 174 000 | 1 100 | 1 500 | 67 | 60.3 |
| 562056 | 562056M | 280 | 289 | 420 | 164 | 82 | 4 | 1.5 | 415 | 1 810 | 42 500 | 185 000 | 1 100 | 1 500 | 71.1 | 64 |
| 562060 | 562060M | 300 | 310 | 460 | 190 | 95 | 4 | 1.5 | 475 | 2 170 | 48 500 | 221 000 | 1 000 | 1 300 | 102 | 91.8 |
| 562964 | 562964M | 320 | 330 | 480 | 190 | 95 | 4 | 1.5 | 480 | 2 230 | 4 900 | 228 000 | 1 000 | 1 300 | 108 | 97.2 |

① Minimum allowable value for corner radius dimension r or r_1 . ② Maximum circumscribed circle diameter of balls.

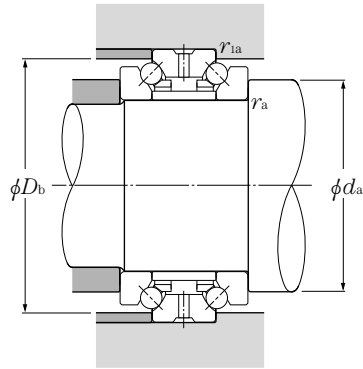

Dynamic equivalent axial load
 $P_a = F_a$
Static equivalent axial load
 $P_{0a} = F_a$

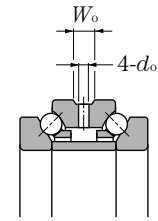

Dimensions of oil hole and oil groove
 unit: mm

| Reference dimensions mm | | Abutment and fillet dimensions mm | | | | Part number | |
|----------------------------|--------------------|--------------------------------------|--------------|-----------------|------------------|-------------|------------|
| J | E_w ^② | d_a min | D_b max | r_{as} max | r_{1as} max | small size | large size |
| 40 | 41.3 | 33 | 44 | 0.6 | 0.3 | 562005 | 562005M |
| 47 | 48.5 | 40 | 50.5 | 1 | 0.6 | 562006 | 562006M |
| 53 | 55 | 45.5 | 57.5 | 1 | 0.6 | 562007 | 562007M |
| 58.5 | 61 | 50 | 63.5 | 1 | 0.6 | 562008 | 562008M |
| 65 | 67.5 | 56.5 | 70.5 | 1 | 0.6 | 562009 | 562009M |
| 70 | 72.5 | 61.5 | 75.5 | 1 | 0.6 | 562010 | 562010M |
| 78 | 81 | 67.5 | 84 | 1 | 0.6 | 562011 | 562011M |
| 83 | 86.1 | 72.5 | 89 | 1 | 0.6 | 562012 | 562012M |
| 88 | 91 | 77.5 | 94 | 1 | 0.6 | 562013 | 562013M |
| 97 | 100 | 85 | 104 | 1 | 0.6 | 562014 | 562014M |
| 102 | 105 | 90 | 109 | 1 | 0.6 | 562015 | 562015M |
| 110 | 113 | 96.5 | 119 | 1 | 0.6 | 562016 | 562016M |
| 115 | 118 | 102 | 124 | 1 | 0.6 | 562017 | 562017M |
| 123 | 127 | 109 | 133.5 | 1.5 | 1 | 562018 | 562018M |
| 128 | 132 | 114 | 138.5 | 1.5 | 1 | 562019 | 562019M |
| 133 | 137 | 119 | 143.5 | 1.5 | 1 | 562020 | 562020M |
| 142 | 146 | 127 | 152 | 2 | 1 | 562021 | 562021M |
| 150 | 155 | 133 | 162 | 2 | 1 | 562022 | 562022M |
| 160 | 165 | 143 | 172 | 2 | 1 | 562024 | 562024M |
| 177 | 182 | 155 | 192 | 2 | 1 | 562026 | 562026M |
| 187 | 192 | 165 | 202 | 2 | 1 | 562028 | 562028M |
| 200 | 206 | 178 | 215 | 2 | 1 | 562030 | 562030M |
| 212 | 219 | 189 | 230 | 2 | 1 | 562032 | 562032M |
| 230 | 236 | 203 | 250 | 2 | 1 | 562034 | 562034M |
| 248 | 255 | 219 | 270 | 2 | 1 | 562036 | 562036M |
| 258 | 265 | 229 | 280 | 2 | 1 | 562038 | 562038M |
| 274 | 282 | 243 | 300 | 2 | 1 | 562040 | 562040M |
| 304 | 310 | 267 | 330 | 2.5 | 1 | 562044 | 562044M |
| 322 | 330 | 287 | 350 | 2.5 | 1 | 562048 | 562048M |
| 354 | 364 | 315 | 388 | 3 | 1.5 | 562052 | 562052M |
| 374 | 384 | 335 | 408 | 3 | 1.5 | 562056 | 562056M |
| 406 | 418 | 364 | 448 | 3 | 1.5 | 562060 | 562060M |
| 426 | 438 | 384 | 468 | 3 | 1.5 | 562964 | 562964M |

| Nominal outer diameter D | | Oil groove width W_o | Oil hole diameter d_o |
|-------------------------------|-------|---------------------------|----------------------------|
| over | incl. | | |
| 150 | 200 | 12 | 6 |
| 200 | 210 | 12 | 6 |
| 210 | 260 | 14 | 6 |
| 260 | 320 | 16 | 8 |

Angular contact ball bearings for axial loads (steel ball type) HTA9UA series

Contact angle 30° d 100~320mm

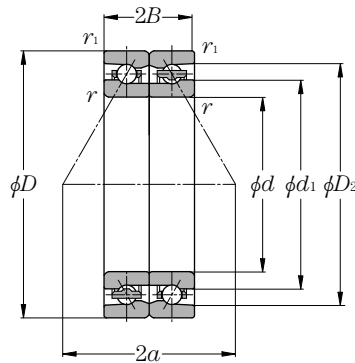

| Part number | Boundary dimensions | | | | | | Basic load ratings | | | | Static thrust load capacity | | Limiting speed | |
|-------------|---------------------|-----|------|-----------------|-----------------|-----------------|--------------------|----------|----------------|----------|-----------------------------|-------|-----------------------|--------------------|
| | mm | | | | | | dynamic kN | | dynamic kgf | | kN | kgf | min ⁻¹ | |
| | d | D | $2B$ | $r_{1s \min}$ ① | $r_{1s \min}$ ① | $r_{1s \min}$ ① | C_a | C_{oa} | C_a | C_{oa} | | | grease lubrication | oil lubrication |
| HTA920UADB | 100 | 140 | 36 | 1.1 | 0.6 | 40.0 | 109 | 4 050 | 11 100 | 66.0 | 6 750 | 8 300 | 10 400 | |
| HTA921UADB | 105 | 145 | 36 | 1.1 | 0.6 | 41.0 | 115 | 4 150 | 11 700 | 70.0 | 7 150 | 8 000 | 10 000 | |
| HTA922UADB | 110 | 150 | 36 | 1.1 | 0.6 | 41.5 | 118 | 4 200 | 12 000 | 72.0 | 7 350 | 7 700 | 9 600 | |
| HTA924UADB | 120 | 165 | 40.5 | 1.1 | 0.6 | 48.0 | 140 | 4 900 | 14 300 | 87.5 | 8 900 | 7 000 | 8 800 | |
| HTA926UADB | 130 | 180 | 45 | 1.5 | 1 | 57.5 | 173 | 5 850 | 17 600 | 103 | 10 500 | 6 500 | 8 100 | |
| HTA928UADB | 140 | 190 | 45 | 1.5 | 1 | 57.5 | 177 | 5 850 | 18 000 | 106 | 10 800 | 6 100 | 7 600 | |
| HTA930UADB | 150 | 210 | 54 | 2 | 1 | 80.5 | 243 | 8 200 | 24 800 | 143 | 14 600 | 5 600 | 6 900 | |
| HTA932UADB | 160 | 220 | 54 | 2 | 1 | 82.0 | 255 | 8 350 | 26 100 | 151 | 15 400 | 5 300 | 6 600 | |
| HTA934UADB | 170 | 230 | 54 | 2 | 1 | 84.0 | 268 | 8 550 | 27 300 | 159 | 16 200 | 5 000 | 6 300 | |
| HTA936UADB | 180 | 250 | 63 | 2 | 1 | 127 | 400 | 12 900 | 41 000 | 239 | 24 400 | 4 700 | 5 800 | |
| HTA938UADB | 190 | 260 | 63 | 2 | 1 | 129 | 420 | 13 200 | 43 000 | 252 | 25 700 | 4 400 | 5 600 | |
| HTA940UADB | 200 | 280 | 72 | 2.1 | 1.1 | 152 | 500 | 15 500 | 51 000 | 305 | 31 000 | 4 200 | 5 200 | |
| HTA944UADB | 220 | 300 | 72 | 2.1 | 1.1 | 156 | 535 | 15 900 | 54 500 | 330 | 33 500 | 3 800 | 4 800 | |
| HTA948UADB | 240 | 320 | 72 | 2.1 | 1.1 | 160 | 570 | 16 300 | 58 000 | 350 | 35 500 | 3 600 | 4 500 | |
| HTA952UADB | 260 | 360 | 90 | 2.1 | 1.1 | 210 | 745 | 21 400 | 76 000 | 460 | 47 000 | 3 200 | 4 000 | |
| HTA956UADB | 280 | 380 | 90 | 2.1 | 1.1 | 216 | 795 | 22 000 | 81 000 | 490 | 50 000 | 3 000 | 3 800 | |
| HTA960UADB | 300 | 420 | 108 | 3 | 1.1 | 276 | 1 020 | 28 100 | 104 000 | 610 | 62 000 | 2 800 | 3 500 | |
| HTA964UADB | 320 | 440 | 108 | 3 | 1.1 | 280 | 1 060 | 28 500 | 108 000 | 635 | 65 000 | 2 600 | 3 300 | |

① Minimum allowable value for corner radius dimension r or r_1 .

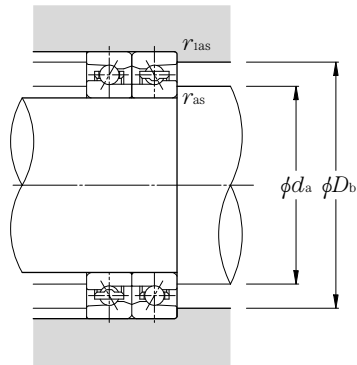

Dynamic equivalent axial load

$$P_a = F_a$$

Static equivalent axial load

$$P_{0a} = F_a$$

| Load center mm $2a$ | Internal free space cm ³ Two row (approx.) | Mass kg Two row (approx.) | Reference dimensions | | Abutment and fillet dimensions mm | | | | Part number |
|---------------------------|---|---------------------------------|----------------------|-------|--------------------------------------|--------------|-----------------|------------------|-------------|
| | | | d_1 | D_2 | d_a min | D_b max | r_{as} max | r_{1as} max | |
| 87.6 | 24 | 0.81 | 115.3 | 129.1 | 110 | 134 | 1 | 0.6 | HTA920UADB |
| 90.5 | 24 | 0.85 | 120.3 | 134.1 | 115 | 139 | 1 | 0.6 | HTA921UADB |
| 93.4 | 26 | 0.88 | 125.3 | 139.1 | 120 | 144 | 1 | 0.6 | HTA922UADB |
| 102.9 | 36 | 1.23 | 137.4 | 152.4 | 130 | 159 | 1 | 0.6 | HTA924UADB |
| 112.4 | 50 | 1.65 | 149.4 | 165.8 | 142 | 172.5 | 1.5 | 1 | HTA926UADB |
| 118.1 | 53 | 1.75 | 159.4 | 175.8 | 152 | 182.5 | 1.5 | 1 | HTA928UADB |
| 131.4 | 85 | 2.74 | 173.1 | 193.3 | 164 | 202.5 | 2 | 1 | HTA930UADB |
| 137.1 | 90 | 2.89 | 183.1 | 203.3 | 174 | 212.5 | 2 | 1 | HTA932UADB |
| 142.9 | 94 | 3.05 | 193.1 | 213.0 | 184 | 222.5 | 2 | 1 | HTA934UADB |
| 156.2 | 138 | 4.78 | 206.4 | 231.4 | 194 | 242.5 | 2 | 1 | HTA936UADB |
| 162.0 | 144 | 5.00 | 216.4 | 241.0 | 204 | 252.5 | 2 | 1 | HTA938UADB |
| 175.2 | 197 | 7.00 | 230.6 | 258.2 | 217 | 270 | 2 | 1 | HTA940UADB |
| 186.7 | 213 | 7.60 | 250.6 | 278.0 | 237 | 290 | 2 | 1 | HTA944UADB |
| 198.3 | 229 | 8.15 | 270.6 | 297.9 | 257 | 310 | 2 | 1 | HTA948UADB |
| 224.7 | 378 | 14.3 | 298.9 | 331.6 | 277 | 350 | 2 | 1 | HTA952UADB |
| 236.3 | 403 | 15.2 | 318.9 | 351.5 | 297 | 370 | 2 | 1 | HTA956UADB |
| 262.7 | 675 | 23.5 | 347.1 | 385.2 | 320 | 410 | 2.5 | 1 | HTA960UADB |
| 274.2 | 715 | 24.8 | 367.1 | 405.1 | 340 | 430 | 2.5 | 1 | HTA964UADB |

Angular contact ball bearings for axial loads (steel ball type) HTA9U series

Contact angle 40° d 100~320mm

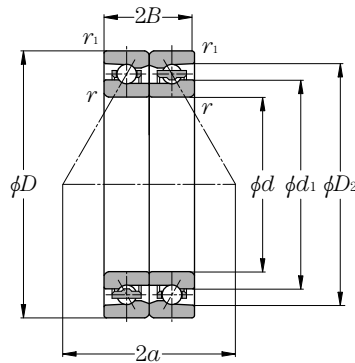

| Part number | Boundary dimensions | | | | | Basic load ratings | | | | Static thrust load capacity | | Limiting speed | |
|-------------|---------------------|-----|------|-----------------|-----------------|--------------------|----------|--------|----------|-----------------------------|--------|--------------------|-----------------|
| | mm | | | | | kN | | kgf | | kN | kgf | min ⁻¹ | |
| | d | D | $2B$ | $r_{1s \min}$ ① | $r_{1s \min}$ ① | C_a | C_{oa} | C_a | C_{oa} | | | grease lubrication | oil lubrication |
| HTA920UDB | 100 | 140 | 36 | 1.1 | 0.6 | 47.0 | 121 | 4 800 | 12 300 | 29.3 | 2 990 | 6 300 | 7 900 |
| HTA921UDB | 105 | 145 | 36 | 1.1 | 0.6 | 48.5 | 128 | 4 950 | 13 000 | 31.0 | 3 150 | 6 000 | 7 600 |
| HTA922UDB | 110 | 150 | 36 | 1.1 | 0.6 | 49.0 | 131 | 5 000 | 13 400 | 32.0 | 3 250 | 5 800 | 7 300 |
| HTA924UDB | 120 | 165 | 40.5 | 1.1 | 0.6 | 57.0 | 156 | 5 800 | 15 900 | 39.0 | 4 000 | 5 300 | 6 700 |
| HTA926UDB | 130 | 180 | 45 | 1.5 | 1 | 68.0 | 193 | 6 950 | 19 600 | 44.5 | 4 550 | 4 800 | 6 100 |
| HTA928UDB | 140 | 190 | 45 | 1.5 | 1 | 68.0 | 197 | 6 950 | 20 100 | 46.0 | 4 700 | 4 500 | 5 800 |
| HTA930UDB | 150 | 210 | 54 | 2 | 1 | 95.5 | 270 | 9 750 | 27 600 | 62.5 | 6 350 | 4 200 | 5 300 |
| HTA932UDB | 160 | 220 | 54 | 2 | 1 | 97.5 | 284 | 9 950 | 29 000 | 65.5 | 6 700 | 3 900 | 5 000 |
| HTA934UDB | 170 | 230 | 54 | 2 | 1 | 99.5 | 298 | 10 100 | 30 500 | 69.0 | 7 050 | 3 800 | 4 800 |
| HTA936UDB | 180 | 250 | 63 | 2 | 1 | 150 | 445 | 15 300 | 45 500 | 104 | 10 600 | 3 500 | 4 400 |
| HTA938UDB | 190 | 260 | 63 | 2 | 1 | 153 | 470 | 15 600 | 48 000 | 110 | 11 200 | 3 300 | 4 200 |
| HTA940UDB | 200 | 280 | 72 | 2.1 | 1.1 | 180 | 555 | 18 400 | 56 500 | 134 | 13 700 | 3 100 | 4 000 |
| HTA944UDB | 220 | 300 | 72 | 2.1 | 1.1 | 185 | 595 | 18 900 | 60 500 | 145 | 14 800 | 2 900 | 3 700 |
| HTA948UDB | 240 | 320 | 72 | 2.1 | 1.1 | 190 | 635 | 19 400 | 64 500 | 155 | 15 800 | 2 700 | 3 400 |
| HTA952UDB | 260 | 360 | 90 | 2.1 | 1.1 | 250 | 830 | 25 400 | 84 500 | 203 | 20 700 | 2 400 | 3 100 |
| HTA956UDB | 280 | 380 | 90 | 2.1 | 1.1 | 257 | 885 | 26 200 | 90 500 | 218 | 22 200 | 2 300 | 2 900 |
| HTA960UDB | 300 | 420 | 108 | 3 | 1.1 | 325 | 1 130 | 33 500 | 115 000 | 266 | 27 100 | 2 100 | 2 600 |
| HTA964UDB | 320 | 440 | 108 | 3 | 1.1 | 330 | 1 180 | 34 000 | 120 000 | 279 | 28 400 | 2 000 | 2 500 |

① Minimum allowable value for corner radius dimension r or r_1 .

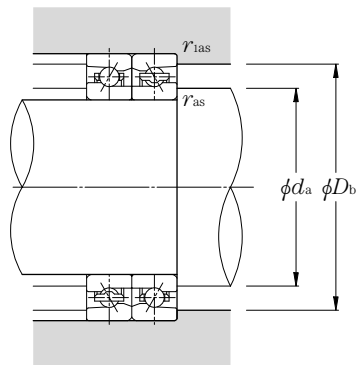

Dynamic equivalent axial load

$$P_a = F_a$$

Static equivalent axial load

$$P_{0a} = F_a$$

| Load center mm $2a$ | Internal free space cm ³ Two row (approx.) | Mass kg Two row (approx.) | Reference dimensions | | Abutment and fillet dimensions mm | | | | Part number |
|---------------------------|---|---------------------------------|----------------------|-------|--------------------------------------|--------------|-----------------|------------------|-------------|
| | | | d_1 | D_2 | d_a min | D_b max | r_{as} max | r_{1as} max | |
| 119.1 | 24 | 0.81 | 115.3 | 129.0 | 110 | 134 | 1 | 0.6 | HTA920UDB |
| 123.3 | 24 | 0.85 | 120.3 | 134.0 | 115 | 139 | 1 | 0.6 | HTA921UDB |
| 127.5 | 26 | 0.88 | 125.3 | 139.0 | 120 | 144 | 1 | 0.6 | HTA922UDB |
| 140.3 | 36 | 1.23 | 137.4 | 152.3 | 130 | 159 | 1 | 0.6 | HTA924UDB |
| 153.1 | 50 | 1.65 | 149.4 | 165.7 | 142 | 172.5 | 1.5 | 1 | HTA926UDB |
| 161.5 | 53 | 1.75 | 159.4 | 175.7 | 152 | 182.5 | 1.5 | 1 | HTA928UDB |
| 178.7 | 85 | 2.74 | 173.1 | 193.2 | 164 | 202.5 | 2 | 1 | HTA930UDB |
| 187.1 | 90 | 2.89 | 183.1 | 203.2 | 174 | 212.5 | 2 | 1 | HTA932UDB |
| 195.5 | 94 | 3.05 | 193.1 | 212.9 | 184 | 222.5 | 2 | 1 | HTA934UDB |
| 212.7 | 138 | 4.78 | 206.4 | 231.5 | 194 | 242.5 | 2 | 1 | HTA936UDB |
| 221.1 | 144 | 5.00 | 216.4 | 241.2 | 204 | 252.5 | 2 | 1 | HTA938UDB |
| 238.3 | 197 | 7.00 | 230.6 | 258.0 | 217 | 270 | 2 | 1 | HTA940UDB |
| 255.1 | 213 | 7.60 | 250.6 | 277.8 | 237 | 290 | 2 | 1 | HTA944UDB |
| 271.8 | 229 | 8.15 | 270.6 | 297.8 | 257 | 310 | 2 | 1 | HTA948UDB |
| 306.2 | 378 | 14.3 | 298.9 | 331.4 | 277 | 350 | 2 | 1 | HTA952UDB |
| 323.0 | 403 | 15.2 | 318.9 | 350.2 | 297 | 370 | 2 | 1 | HTA956UDB |
| 357.3 | 675 | 23.5 | 347.1 | 385.0 | 320 | 410 | 2.5 | 1 | HTA960UDB |
| 374.1 | 715 | 24.8 | 367.1 | 404.1 | 340 | 430 | 2.5 | 1 | HTA964UDB |

Angular contact ball bearings for axial loads (steel ball type) HTA0UA series

Contact angle 30° d 50~320mm

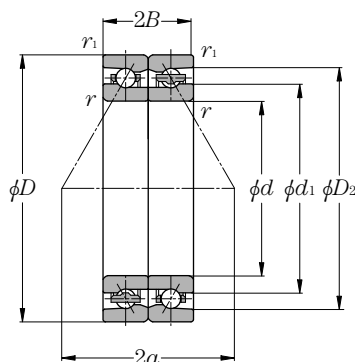

| Part number | Boundary dimensions | | | | | | Basic load ratings | | | | Static thrust load capacity | | Limiting speed | |
|-------------|---------------------|-----|-------|-----------------|-----------------|-------|--------------------|--------|----------------|-----------------------|-----------------------------|--------|--------------------|--|
| | mm | | | | | | dynamic kN | | dynamic kgf | | kN | kgf | min ⁻¹ | |
| | d | D | $2B$ | $r_{1s \min}$ ① | $r_{1s \min}$ ① | C_a | C_{oa} | C_a | C_{oa} | grease lubrication | | | oil lubrication | |
| HTA010UADB | 50 | 80 | 28.5 | 1 | 0.6 | 24.7 | 48.5 | 2 520 | 4 950 | 23.2 | 2 370 | 15 400 | 19 200 | |
| HTA011UADB | 55 | 90 | 33 | 1.1 | 0.6 | 26.8 | 57.5 | 2 730 | 5 850 | 27.7 | 2 820 | 13 800 | 17 200 | |
| HTA012UADB | 60 | 95 | 33 | 1.1 | 0.6 | 28.1 | 63.0 | 2 860 | 6 400 | 30.5 | 3 100 | 12 900 | 16 100 | |
| HTA013UADB | 65 | 100 | 33 | 1.1 | 0.6 | 28.5 | 65.0 | 2 900 | 6 650 | 32.0 | 3 250 | 12 100 | 15 200 | |
| HTA014UADB | 70 | 110 | 36 | 1.1 | 0.6 | 35.0 | 82.0 | 3 550 | 8 350 | 40.0 | 4 100 | 11 100 | 13 900 | |
| HTA015UADB | 75 | 115 | 36 | 1.1 | 0.6 | 37.0 | 91.5 | 3 800 | 9 300 | 45.5 | 4 650 | 10 500 | 13 200 | |
| HTA016UADB | 80 | 125 | 40.5 | 1.1 | 0.6 | 42.5 | 105 | 4 350 | 10 700 | 52.0 | 5 300 | 9 800 | 12 200 | |
| HTA017UADB | 85 | 130 | 40.5 | 1.1 | 0.6 | 43.0 | 108 | 4 400 | 11 100 | 54.5 | 5 550 | 9 300 | 11 600 | |
| HTA018UADB | 90 | 140 | 45 | 1.5 | 1 | 50.0 | 127 | 5 100 | 13 000 | 63.5 | 6 500 | 8 700 | 10 900 | |
| HTA019UADB | 95 | 145 | 45 | 1.5 | 1 | 50.5 | 131 | 5 150 | 13 400 | 66.0 | 6 750 | 8 300 | 10 400 | |
| HTA020UADB | 100 | 150 | 45 | 1.5 | 1 | 52.5 | 140 | 5 350 | 14 300 | 71.0 | 7 250 | 8 000 | 10 000 | |
| HTA021UADB | 105 | 160 | 49.5 | 2 | 1 | 60.0 | 163 | 6 100 | 16 600 | 82.5 | 8 400 | 7 500 | 9 400 | |
| HTA022UADB | 110 | 170 | 54 | 2 | 1 | 74.5 | 200 | 7 600 | 20 400 | 100 | 10 200 | 7 100 | 8 900 | |
| HTA024UADB | 120 | 180 | 54 | 2 | 1 | 75.0 | 206 | 7 650 | 21 000 | 104 | 10 600 | 6 700 | 8 300 | |
| HTA026UADB | 130 | 200 | 63 | 2 | 1 | 108 | 293 | 11 000 | 29 900 | 144 | 14 700 | 6 100 | 7 600 | |
| HTA028UADB | 140 | 210 | 63 | 2 | 1 | 111 | 315 | 11 300 | 32 000 | 156 | 15 900 | 5 700 | 7 100 | |
| HTA030UADB | 150 | 225 | 67.5 | 2.1 | 1.1 | 114 | 330 | 11 700 | 34 000 | 169 | 17 200 | 5 300 | 6 700 | |
| HTA032UADB | 160 | 240 | 72 | 2.1 | 1.1 | 134 | 390 | 13 700 | 40 000 | 196 | 20 000 | 5 000 | 6 300 | |
| HTA034UADB | 170 | 260 | 81 | 2.1 | 1.1 | 153 | 450 | 15 900 | 46 000 | 226 | 23 000 | 4 700 | 5 800 | |
| HTA036UADB | 180 | 280 | 90 | 2.1 | 1.1 | 177 | 530 | 18 100 | 54 000 | 265 | 27 000 | 4 300 | 5 400 | |
| HTA038UADB | 190 | 290 | 91 | 2.1 | 1.1 | 179 | 545 | 18 300 | 55 500 | 275 | 28 000 | 4 200 | 5 200 | |
| HTA040UADB | 200 | 310 | 99 | 2.1 | 1.1 | 201 | 610 | 20 500 | 62 000 | 310 | 31 500 | 3 900 | 4 900 | |
| HTA044UADB | 220 | 340 | 108 | 3 | 1.1 | 253 | 775 | 25 800 | 79 000 | 385 | 39 500 | 3 600 | 4 500 | |
| HTA048UADB | 240 | 360 | 108 | 3 | 1.1 | 261 | 825 | 26 600 | 84 000 | 415 | 42 500 | 3 300 | 4 200 | |
| HTA052UADB | 260 | 400 | 123 | 4 | 1.5 | 310 | 1040 | 31 500 | 106 000 | 520 | 53 500 | 3 000 | 3 800 | |
| HTA056UADB | 280 | 420 | 123 | 4 | 1.5 | 315 | 1110 | 32 500 | 113 000 | 565 | 57 500 | 2 900 | 3 600 | |
| HTA060UADB | 300 | 460 | 142.5 | 4 | 1.5 | 360 | 1330 | 37 000 | 135 000 | 670 | 68 500 | 2 600 | 3 300 | |
| HTA064UADB | 320 | 480 | 142.5 | 4 | 1.5 | 365 | 1360 | 37 000 | 139 000 | 700 | 71 500 | 2 500 | 3 100 | |

① Minimum allowable value for corner radius dimension r or r_1 .

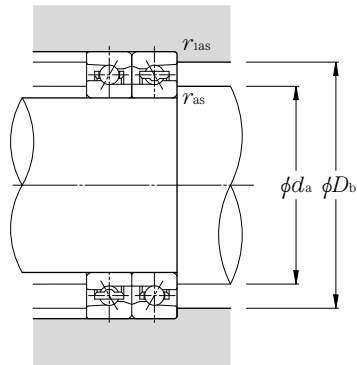

Dynamic equivalent axial load

$$P_a = F_a$$

Static equivalent axial load

$$P_{0a} = F_a$$

| Load center mm <i>2a</i> | Internal free space cm ³ Two row (approx.) | Mass kg Two row (approx.) | Reference dimensions | | Abutment and fillet dimensions mm | | | | Part number |
|--------------------------------|---|---------------------------------|-----------------------|-----------------------|--------------------------------------|------------------------------|-------------------------------|--------------------------------|-------------|
| | | | <i>d</i> ₁ | <i>D</i> ₂ | <i>d</i> _a min | <i>D</i> _b max | <i>r</i> _{as} max | <i>r</i> _{1as} max | |
| 52.1 | 9 | 0.24 | 60.7 | 73.2 | 57.5 | 74.0 | 1 | 0.6 | HTA010UADB |
| 58.6 | 13 | 0.39 | 68.2 | 80.8 | 65.0 | 84.0 | 1 | 0.6 | HTA011UADB |
| 61.5 | 13 | 0.41 | 73.2 | 85.8 | 70.0 | 89.0 | 1 | 0.6 | HTA012UADB |
| 64.4 | 14 | 0.44 | 78.2 | 90.8 | 75.0 | 94.0 | 1 | 0.6 | HTA013UADB |
| 70.3 | 18 | 0.61 | 85.3 | 99.1 | 80.0 | 104 | 1 | 0.6 | HTA014UADB |
| 73.2 | 19 | 0.65 | 90.3 | 104.1 | 85.0 | 109 | 1 | 0.6 | HTA015UADB |
| 79.8 | 26 | 0.88 | 97.4 | 112.5 | 90.0 | 119 | 1 | 0.6 | HTA016UADB |
| 82.7 | 28 | 0.93 | 102.4 | 117.5 | 95.0 | 124 | 1 | 0.6 | HTA017UADB |
| 89.3 | 38 | 1.22 | 109.4 | 125.9 | 102 | 132.5 | 1.5 | 1 | HTA018UADB |
| 92.1 | 39 | 1.27 | 114.4 | 130.9 | 107 | 137.5 | 1.5 | 1 | HTA019UADB |
| 95.1 | 39 | 1.34 | 119.5 | 136.0 | 112 | 142.5 | 1.5 | 1 | HTA020UADB |
| 101.6 | 49 | 1.74 | 126.5 | 144.3 | 119 | 152.5 | 2 | 1 | HTA021UADB |
| 108.3 | 66 | 2.14 | 133.1 | 153.4 | 124 | 162.5 | 2 | 1 | HTA022UADB |
| 114.1 | 67 | 2.32 | 143.3 | 163.5 | 134 | 172.5 | 2 | 1 | HTA024UADB |
| 127.3 | 108 | 3.39 | 156.4 | 181.7 | 144 | 192.5 | 2 | 1 | HTA026UADB |
| 133.1 | 114 | 3.60 | 166.4 | 191.7 | 154 | 202.5 | 2 | 1 | HTA028UADB |
| 142.6 | 141 | 4.46 | 178.9 | 204.3 | 167 | 215 | 2 | 1 | HTA030UADB |
| 152.1 | 168 | 5.40 | 190.6 | 218.0 | 177 | 230 | 2 | 1 | HTA032UADB |
| 165.3 | 238 | 7.20 | 204.7 | 235.3 | 187 | 250 | 2 | 1 | HTA034UADB |
| 178.5 | 285 | 10.6 | 218.9 | 251.8 | 197 | 270 | 2 | 1 | HTA036UADB |
| 184.3 | 300 | 11.0 | 228.9 | 261.8 | 207 | 280 | 2 | 1 | HTA038UADB |
| 197.5 | 436 | 13.8 | 243.0 | 277.6 | 217 | 300 | 2 | 1 | HTA040UADB |
| 216.6 | 550 | 18.1 | 266.3 | 306.0 | 240 | 330 | 2.5 | 1 | HTA044UADB |
| 228.1 | 650 | 18.9 | 286.3 | 326.8 | 260 | 350 | 2.5 | 1 | HTA048UADB |
| 253.0 | 850 | 28.4 | 314.6 | 360.3 | 283 | 388 | 3 | 1.5 | HTA052UADB |
| 264.6 | 900 | 30.2 | 334.6 | 380.2 | 303 | 408 | 3 | 1.5 | HTA056UADB |
| 291.8 | 1265 | 43.6 | 362.9 | 413.9 | 323 | 448 | 3 | 1.5 | HTA060UADB |
| 303.3 | 1340 | 45.8 | 382.9 | 433.9 | 343 | 468 | 3 | 1.5 | HTA064UADB |

Angular contact ball bearings for axial loads (steel ball type) HTA0U series

Contact angle 40° d 50~320mm

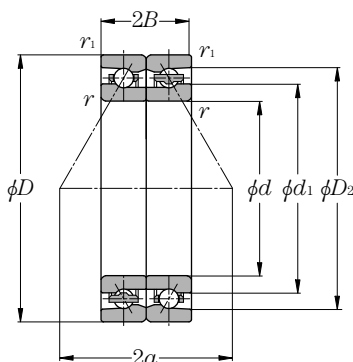

| Part number | Boundary dimensions | | | | | Basic load ratings | | | | Static thrust load capacity | | Limiting speed | |
|-------------|---------------------|-----|-------|-----------------|-----------------|--------------------|----------|--------|----------|-----------------------------|--------|--------------------|-----------------|
| | mm | | | | | kN | | kgf | | kN | kgf | min ⁻¹ | |
| | d | D | $2B$ | $r_{1s \min}$ ① | $r_{1s \min}$ ① | C_a | C_{oa} | C_a | C_{oa} | | | grease lubrication | oil lubrication |
| HTA010UDB | 50 | 80 | 28.5 | 1 | 0.6 | 29.6 | 55.5 | 3 000 | 5 650 | 12.3 | 1 250 | 11 500 | 14 600 |
| HTA011UDB | 55 | 90 | 33 | 1.1 | 0.6 | 32.0 | 64.0 | 3 250 | 6 500 | 14.3 | 1 460 | 10 300 | 13 100 |
| HTA012UDB | 60 | 95 | 33 | 1.1 | 0.6 | 33.5 | 69.5 | 3 400 | 7 100 | 15.7 | 1 600 | 9 700 | 12 300 |
| HTA013UDB | 65 | 100 | 33 | 1.1 | 0.6 | 34.0 | 72.0 | 3 450 | 7 350 | 16.4 | 1 670 | 9 100 | 11 500 |
| HTA014UDB | 70 | 110 | 36 | 1.1 | 0.6 | 41.5 | 91.0 | 4 250 | 9 300 | 21.5 | 2 190 | 8 300 | 10 600 |
| HTA015UDB | 75 | 115 | 36 | 1.1 | 0.6 | 44.0 | 101.0 | 4 500 | 10 300 | 24.0 | 2 450 | 7 900 | 10 000 |
| HTA016UDB | 80 | 125 | 40.5 | 1.1 | 0.6 | 50.5 | 117 | 5 150 | 11 900 | 28.4 | 2 900 | 7 300 | 9 300 |
| HTA017UDB | 85 | 130 | 40.5 | 1.1 | 0.6 | 51.0 | 120 | 5 200 | 12 300 | 29.4 | 3 000 | 7 000 | 8 800 |
| HTA018UDB | 90 | 140 | 45 | 1.5 | 1 | 59.5 | 141 | 6 050 | 14 400 | 32.0 | 3 250 | 6 500 | 8 300 |
| HTA019UDB | 95 | 145 | 45 | 1.5 | 1 | 60.0 | 146 | 6 100 | 14 900 | 33.5 | 3 400 | 6 300 | 7 900 |
| HTA020UDB | 100 | 150 | 45 | 1.5 | 1 | 62.0 | 156 | 6 350 | 15 900 | 35.5 | 3 600 | 6 000 | 7 600 |
| HTA021UDB | 105 | 160 | 49.5 | 2 | 1 | 71.0 | 181 | 7 250 | 18 400 | 42.5 | 4 350 | 5 700 | 7 200 |
| HTA022UDB | 110 | 170 | 54 | 2 | 1 | 88.5 | 222 | 9 000 | 22 700 | 50.0 | 5 100 | 5 400 | 6 800 |
| HTA024UDB | 120 | 180 | 54 | 2 | 1 | 89.0 | 228 | 9 050 | 23 300 | 52.0 | 5 300 | 5 000 | 6 300 |
| HTA026UDB | 130 | 200 | 63 | 2 | 1 | 128 | 325 | 13 000 | 33 000 | 74.0 | 7 550 | 4 500 | 5 800 |
| HTA028UDB | 140 | 210 | 63 | 2 | 1 | 132 | 345 | 13 500 | 35 500 | 79.5 | 8 100 | 4 300 | 5 400 |
| HTA030UDB | 150 | 225 | 67.5 | 2.1 | 1.1 | 136 | 370 | 13 800 | 37 500 | 85.0 | 8 650 | 4 000 | 5 200 |
| HTA032UDB | 160 | 240 | 72 | 2.1 | 1.1 | 159 | 435 | 16 200 | 44 000 | 103 | 10 500 | 3 800 | 4 800 |
| HTA034UDB | 170 | 260 | 81 | 2.1 | 1.1 | 182 | 500 | 18 600 | 51 000 | 116 | 11 800 | 3 500 | 4 400 |
| HTA036UDB | 180 | 280 | 90 | 2.1 | 1.1 | 211 | 585 | 21 500 | 60 000 | 140 | 14 300 | 3 300 | 4 100 |
| HTA038UDB | 190 | 290 | 91 | 2.1 | 1.1 | 214 | 605 | 21 800 | 61 500 | 145 | 14 800 | 3 100 | 4 000 |
| HTA040UDB | 200 | 310 | 99 | 2.1 | 1.1 | 240 | 680 | 24 400 | 69 000 | 159 | 16 200 | 2 900 | 3 700 |
| HTA044UDB | 220 | 340 | 108 | 3 | 1.1 | 300 | 860 | 30 500 | 87 500 | 201 | 20 500 | 2 700 | 3 400 |
| HTA048UDB | 240 | 360 | 108 | 3 | 1.1 | 310 | 915 | 31 500 | 93 000 | 216 | 22 000 | 2 500 | 3 200 |
| HTA052UDB | 260 | 400 | 123 | 4 | 1.5 | 365 | 1160 | 37 500 | 118 000 | 275 | 28 000 | 2 300 | 2 900 |
| HTA056UDB | 280 | 420 | 123 | 4 | 1.5 | 375 | 1230 | 38 500 | 125 000 | 293 | 29 900 | 2 100 | 2 700 |
| HTA060UDB | 300 | 460 | 142.5 | 4 | 1.5 | 430 | 1470 | 44 000 | 150 000 | 355 | 36 000 | 2 000 | 2 500 |
| HTA064UDB | 320 | 480 | 142.5 | 4 | 1.5 | 435 | 1520 | 44 000 | 155 000 | 365 | 37 000 | 1 900 | 2 400 |

① Minimum allowable value for corner radius dimension r or r_1 .

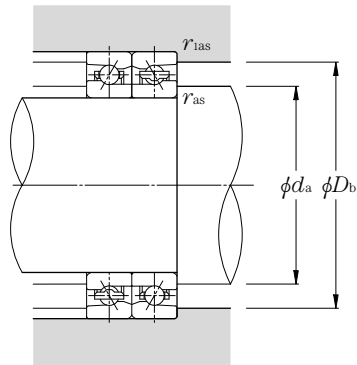

Dynamic equivalent axial load

$$P_a = F_a$$

Static equivalent axial load

$$P_{0a} = F_a$$

| Load center mm $2a$ | Internal free space cm ³ Two row (approx.) | Mass kg Two row (approx.) | Reference dimensions | | Abutment and fillet dimensions mm | | | | Part number |
|---------------------------|---|---------------------------------|----------------------|-------|--------------------------------------|--------------|-----------------|------------------|-------------|
| | | | d_1 | D_2 | d_a min | D_b max | r_{as} max | r_{1as} max | |
| 69.2 | 9 | 0.24 | 60.7 | 73.1 | 57.5 | 74.0 | 1 | 0.6 | HTA010UDB |
| 77.7 | 13 | 0.39 | 68.2 | 80.7 | 65.0 | 84.0 | 1 | 0.6 | HTA011UDB |
| 81.9 | 13 | 0.41 | 73.2 | 85.7 | 70.0 | 89.0 | 1 | 0.6 | HTA012UDB |
| 86.1 | 14 | 0.44 | 78.2 | 90.7 | 75.0 | 94.0 | 1 | 0.6 | HTA013UDB |
| 94.0 | 18 | 0.61 | 85.3 | 99.0 | 80.0 | 104 | 1 | 0.6 | HTA014UDB |
| 98.2 | 19 | 0.65 | 90.3 | 104.0 | 85.0 | 109 | 1 | 0.6 | HTA015UDB |
| 106.7 | 26 | 0.88 | 97.4 | 112.4 | 90.0 | 119 | 1 | 0.6 | HTA016UDB |
| 110.9 | 28 | 0.93 | 102.4 | 117.4 | 95.0 | 124 | 1 | 0.6 | HTA017UDB |
| 119.5 | 38 | 1.22 | 109.4 | 125.8 | 102 | 132.5 | 1.5 | 1 | HTA018UDB |
| 123.7 | 39 | 1.27 | 114.4 | 130.8 | 107 | 137.5 | 1.5 | 1 | HTA019UDB |
| 128.0 | 39 | 1.34 | 119.5 | 135.9 | 112 | 142.5 | 1.5 | 1 | HTA020UDB |
| 136.5 | 49 | 1.74 | 126.5 | 144.2 | 119 | 152.5 | 2 | 1 | HTA021UDB |
| 145.1 | 66 | 2.14 | 133.1 | 153.3 | 124 | 162.5 | 2 | 1 | HTA022UDB |
| 153.6 | 67 | 2.32 | 143.3 | 163.4 | 134 | 172.5 | 2 | 1 | HTA024UDB |
| 170.8 | 108 | 3.39 | 156.4 | 181.6 | 144 | 192.5 | 2 | 1 | HTA026UDB |
| 179.2 | 114 | 3.60 | 166.4 | 191.6 | 154 | 202.5 | 2 | 1 | HTA028UDB |
| 191.9 | 141 | 4.46 | 178.9 | 204.2 | 167 | 215 | 2 | 1 | HTA030UDB |
| 204.7 | 168 | 5.40 | 190.6 | 218.4 | 177 | 230 | 2 | 1 | HTA032UDB |
| 221.9 | 238 | 7.20 | 204.7 | 235.2 | 187 | 250 | 2 | 1 | HTA034UDB |
| 239.1 | 285 | 10.6 | 218.9 | 251.0 | 197 | 270 | 2 | 1 | HTA036UDB |
| 247.4 | 300 | 11.0 | 228.9 | 261.7 | 207 | 280 | 2 | 1 | HTA038UDB |
| 264.6 | 436 | 13.8 | 243.0 | 277.6 | 217 | 300 | 2 | 1 | HTA040UDB |
| 290.3 | 550 | 18.1 | 266.3 | 306.6 | 240 | 330 | 2.5 | 1 | HTA044UDB |
| 307.0 | 650 | 18.9 | 286.3 | 326.6 | 260 | 350 | 2.5 | 1 | HTA048UDB |
| 339.9 | 850 | 28.4 | 314.6 | 360.1 | 283 | 388 | 3 | 1.5 | HTA052UDB |
| 356.7 | 900 | 30.2 | 334.6 | 380.0 | 303 | 408 | 3 | 1.5 | HTA056UDB |
| 391.7 | 1265 | 43.6 | 362.9 | 413.7 | 323 | 448 | 3 | 1.5 | HTA060UDB |
| 408.5 | 1340 | 45.8 | 382.9 | 433.7 | 343 | 468 | 3 | 1.5 | HTA064UDB |

Angular contact ball bearings for axial loads (ceramic ball type) 5S-HTA0UA series

Contact angle 30° d 50~130mm

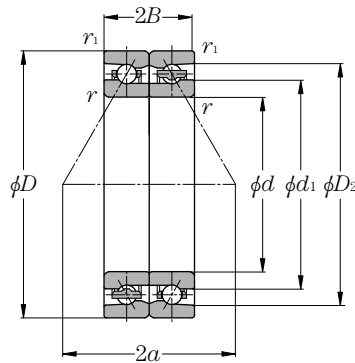

| Part number | Boundary dimensions | | | | | Basic load ratings | | | | Static thrust load capacity | | Limiting speed | |
|---------------|---------------------|-----|------|--------------------------|--------------------------|--------------------|----------|-------------|----------|-----------------------------|-------|--------------------|-----------------|
| | mm | | | | | dynamic kN | | dynamic kgf | | kN | | min ⁻¹ | |
| | d | D | $2B$ | $r_{1s \min}^{\text{①}}$ | $r_{1s \min}^{\text{①}}$ | C_a | C_{oa} | C_a | C_{oa} | | | grease lubrication | oil lubrication |
| 5S-HTA010UADB | 50 | 80 | 28.5 | 1 | 0.6 | 24.7 | 33.5 | 2 520 | 3 400 | 15.7 | 1 600 | 17 300 | 22 200 |
| 5S-HTA011UADB | 55 | 90 | 33 | 1.1 | 0.6 | 26.8 | 40.0 | 2 730 | 4 050 | 18.6 | 1 900 | 15 500 | 19 900 |
| 5S-HTA012UADB | 60 | 95 | 33 | 1.1 | 0.6 | 28.1 | 43.5 | 2 860 | 4 450 | 20.5 | 2 090 | 14 500 | 18 600 |
| 5S-HTA013UADB | 65 | 100 | 33 | 1.1 | 0.6 | 28.5 | 45.0 | 2 900 | 4 600 | 21.6 | 2 200 | 13 600 | 17 500 |
| 5S-HTA014UADB | 70 | 110 | 36 | 1.1 | 0.6 | 35.0 | 57.0 | 3 550 | 5 800 | 27.2 | 2 770 | 12 500 | 16 000 |
| 5S-HTA015UADB | 75 | 115 | 36 | 1.1 | 0.6 | 37.0 | 63.5 | 3 800 | 6 450 | 30.5 | 3 150 | 11 800 | 15 200 |
| 5S-HTA016UADB | 80 | 125 | 40.5 | 1.1 | 0.6 | 42.5 | 73.0 | 4 350 | 7 400 | 35.0 | 3 600 | 11 000 | 14 100 |
| 5S-HTA017UADB | 85 | 130 | 40.5 | 1.1 | 0.6 | 43.0 | 75.0 | 4 400 | 7 650 | 36.5 | 3 750 | 10 500 | 13 400 |
| 5S-HTA018UADB | 90 | 140 | 45 | 1.5 | 1 | 49.5 | 88.5 | 5 050 | 9 000 | 43.0 | 4 400 | 9 800 | 12 500 |
| 5S-HTA019UADB | 95 | 145 | 45 | 1.5 | 1 | 50.5 | 91.0 | 5 150 | 9 300 | 44.5 | 4 550 | 9 400 | 12 000 |
| 5S-HTA020UADB | 100 | 150 | 45 | 1.5 | 1 | 52.5 | 97.0 | 5 350 | 9 900 | 48.0 | 4 900 | 9 000 | 11 500 |
| 5S-HTA021UADB | 105 | 160 | 49.5 | 2 | 1 | 60.0 | 113 | 6 100 | 11 500 | 55.5 | 5 650 | 8 500 | 10 900 |
| 5S-HTA022UADB | 110 | 170 | 54 | 2 | 1 | 74.0 | 139 | 7 550 | 14 100 | 67.0 | 6 850 | 8 000 | 10 300 |
| 5S-HTA024UADB | 120 | 180 | 54 | 2 | 1 | 75.0 | 143 | 7 650 | 14 500 | 70.0 | 7 150 | 7 500 | 9 600 |
| 5S-HTA026UADB | 130 | 200 | 63 | 2 | 1 | 108 | 203 | 11 000 | 20 700 | 97.0 | 9 900 | 6 800 | 8 700 |

① Minimum allowable value for corner radius dimension r or r_1 .

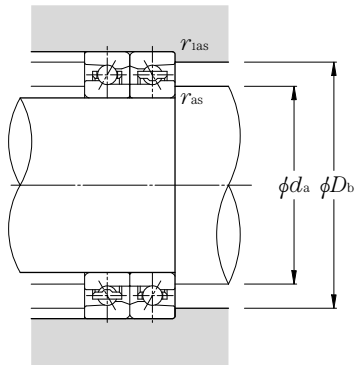

Dynamic equivalent axial load

$$P_a = F_a$$

Static equivalent axial load

$$P_{0a} = F_a$$

| Load center mm $2a$ | Internal free space cm^3 Two row (approx.) | Mass kg Two row (approx.) | Reference dimensions | | Abutment and fillet dimensions mm | | | | Part number |
|---------------------------|---|---------------------------------|----------------------|-------|--------------------------------------|--------------|-----------------|------------------|---------------|
| | | | d_1 | D_2 | d_a min | D_b max | r_{as} max | r_{1as} max | |
| 52.1 | 9 | 0.22 | 60.7 | 73.2 | 57.5 | 74.0 | 1 | 0.6 | 5S-HTA010UADB |
| 58.6 | 13 | 0.36 | 68.2 | 80.8 | 65.0 | 84.0 | 1 | 0.6 | 5S-HTA011UADB |
| 61.5 | 13 | 0.39 | 73.2 | 85.8 | 70.0 | 89.0 | 1 | 0.6 | 5S-HTA012UADB |
| 64.4 | 14 | 0.41 | 78.2 | 90.8 | 75.0 | 94.0 | 1 | 0.6 | 5S-HTA013UADB |
| 70.3 | 18 | 0.57 | 85.3 | 99.1 | 80.0 | 104 | 1 | 0.6 | 5S-HTA014UADB |
| 73.2 | 19 | 0.60 | 90.3 | 104.1 | 85.0 | 109 | 1 | 0.6 | 5S-HTA015UADB |
| 79.8 | 26 | 0.83 | 97.4 | 112.5 | 90.0 | 119 | 1 | 0.6 | 5S-HTA016UADB |
| 82.7 | 28 | 0.87 | 102.4 | 117.5 | 95.0 | 124 | 1 | 0.6 | 5S-HTA017UADB |
| 89.3 | 38 | 1.15 | 109.4 | 125.9 | 102 | 132.5 | 1.5 | 1 | 5S-HTA018UADB |
| 92.1 | 39 | 1.20 | 114.4 | 130.9 | 107 | 137.5 | 1.5 | 1 | 5S-HTA019UADB |
| 95.1 | 39 | 1.26 | 119.5 | 136.0 | 112 | 142.5 | 1.5 | 1 | 5S-HTA020UADB |
| 101.6 | 49 | 1.64 | 126.5 | 144.3 | 119 | 152.5 | 2 | 1 | 5S-HTA021UADB |
| 108.3 | 66 | 2.00 | 133.1 | 153.4 | 124 | 162.5 | 2 | 1 | 5S-HTA022UADB |
| 114.1 | 67 | 2.17 | 143.3 | 163.5 | 134 | 172.5 | 2 | 1 | 5S-HTA024UADB |
| 127.3 | 108 | 3.13 | 156.4 | 181.7 | 144 | 192.5 | 2 | 1 | 5S-HTA026UADB |

Angular contact ball bearings for axial loads (ceramic ball type) 5S-HTA0U series

Contact angle 40° d 50~130mm

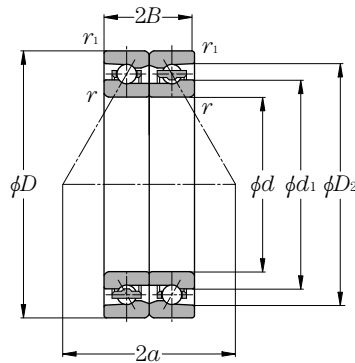

| Part number | Boundary dimensions | | | | | Basic load ratings | | | | Static thrust load capacity | | Limiting speed | |
|--------------|---------------------|----------|-----------|------------------------------|------------------------------|----------------------|-----------------------|----------------------|-----------------------|-----------------------------|-------|--------------------|-----------------|
| | mm | | | | | dynamic kN | | dynamic kgf | | kN | kgf | min ⁻¹ | |
| | <i>d</i> | <i>D</i> | <i>2B</i> | <i>r</i> 's min ^① | <i>r</i> 's min ^① | <i>C_a</i> | <i>C_{oa}</i> | <i>C_a</i> | <i>C_{oa}</i> | | | grease lubrication | oil lubrication |
| 5S-HTA010UDB | 50 | 80 | 28.5 | 1 | 0.6 | 29.6 | 38.5 | 3 000 | 3 900 | 14.6 | 1 490 | 12 200 | 15 400 |
| 5S-HTA011UDB | 55 | 90 | 33 | 1.1 | 0.6 | 32.0 | 44.5 | 3 250 | 4 500 | 17.1 | 1 740 | 10 900 | 13 800 |
| 5S-HTA012UDB | 60 | 95 | 33 | 1.1 | 0.6 | 33.5 | 48.0 | 3 400 | 4 900 | 18.7 | 1 910 | 10 200 | 12 900 |
| 5S-HTA013UDB | 65 | 100 | 33 | 1.1 | 0.6 | 34.0 | 50.0 | 3 450 | 5 100 | 19.6 | 2 000 | 9 600 | 12 100 |
| 5S-HTA014UDB | 70 | 110 | 36 | 1.1 | 0.6 | 41.5 | 63.0 | 4 250 | 6 450 | 25.6 | 2 610 | 8 800 | 11 100 |
| 5S-HTA015UDB | 75 | 115 | 36 | 1.1 | 0.6 | 44.0 | 70.5 | 4 500 | 7 150 | 28.7 | 2 930 | 8 300 | 10 500 |
| 5S-HTA016UDB | 80 | 125 | 40.5 | 1.1 | 0.6 | 50.5 | 81.0 | 5 150 | 8 250 | 34.0 | 3 450 | 7 700 | 9 800 |
| 5S-HTA017UDB | 85 | 130 | 40.5 | 1.1 | 0.6 | 51.0 | 83.5 | 5 200 | 8 500 | 35.0 | 3 600 | 7 300 | 9 300 |
| 5S-HTA018UDB | 90 | 140 | 45 | 1.5 | 1 | 59.5 | 98.0 | 6 050 | 10 000 | 38.0 | 3 900 | 6 900 | 8 700 |
| 5S-HTA019UDB | 95 | 145 | 45 | 1.5 | 1 | 60.0 | 101 | 6 100 | 10 300 | 39.5 | 4 050 | 6 600 | 8 300 |
| 5S-HTA020UDB | 100 | 150 | 45 | 1.5 | 1 | 62.0 | 108 | 6 350 | 11 000 | 42.5 | 4 300 | 6 300 | 8 000 |
| 5S-HTA021UDB | 105 | 160 | 49.5 | 2 | 1 | 71.0 | 125 | 7 250 | 12 800 | 50.5 | 5 150 | 6 000 | 7 500 |
| 5S-HTA022UDB | 110 | 170 | 54 | 2 | 1 | 88.5 | 154 | 9 000 | 15 700 | 59.5 | 6 100 | 5 600 | 7 100 |
| 5S-HTA024UDB | 120 | 180 | 54 | 2 | 1 | 89.0 | 158 | 9 050 | 16 100 | 61.5 | 6 300 | 5 300 | 6 700 |
| 5S-HTA026UDB | 130 | 200 | 63 | 2 | 1 | 128 | 225 | 13 000 | 23 000 | 88.0 | 9 000 | 4 800 | 6 100 |

① Minimum allowable value for corner radius dimension *r* or *r*₁.

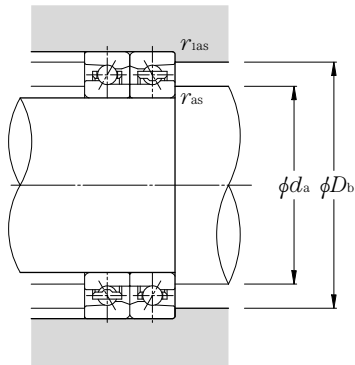

Dynamic equivalent axial load

$$P_a = F_a$$

Static equivalent axial load

$$P_{0a} = F_a$$

| Load center mm $2a$ | Internal free space cm^3 Two row (approx.) | Mass kg Two row (approx.) | Reference dimensions | | Abutment and fillet dimensions mm | | | | Part number |
|---------------------------|---|---------------------------------|----------------------|-------|--------------------------------------|--------------|-----------------|------------------|--------------|
| | | | d_1 | D_2 | d_a min | D_b max | r_{as} max | r_{1as} max | |
| 69.2 | 9 | 0.22 | 60.7 | 73.1 | 57.5 | 74.0 | 1 | 0.6 | 5S-HTA010UDB |
| 77.7 | 13 | 0.36 | 68.2 | 80.7 | 65.0 | 84.0 | 1 | 0.6 | 5S-HTA011UDB |
| 81.9 | 13 | 0.39 | 73.2 | 85.7 | 70.0 | 89.0 | 1 | 0.6 | 5S-HTA012UDB |
| 86.1 | 14 | 0.41 | 78.2 | 90.7 | 75.0 | 94.0 | 1 | 0.6 | 5S-HTA013UDB |
| 94.0 | 18 | 0.57 | 85.3 | 99.0 | 80.0 | 104 | 1 | 0.6 | 5S-HTA014UDB |
| 98.2 | 19 | 0.60 | 90.3 | 104.0 | 85.0 | 109 | 1 | 0.6 | 5S-HTA015UDB |
| 106.7 | 26 | 0.83 | 97.4 | 112.4 | 90.0 | 119 | 1 | 0.6 | 5S-HTA016UDB |
| 110.9 | 28 | 0.87 | 102.4 | 117.4 | 95.0 | 124 | 1 | 0.6 | 5S-HTA017UDB |
| 119.5 | 38 | 1.15 | 109.4 | 125.8 | 102 | 132.5 | 1.5 | 1 | 5S-HTA018UDB |
| 123.7 | 39 | 1.20 | 114.4 | 130.8 | 107 | 137.5 | 1.5 | 1 | 5S-HTA019UDB |
| 128.0 | 39 | 1.26 | 119.5 | 135.9 | 112 | 142.5 | 1.5 | 1 | 5S-HTA020UDB |
| 136.5 | 49 | 1.64 | 126.5 | 144.2 | 119 | 152.5 | 2 | 1 | 5S-HTA021UDB |
| 145.1 | 66 | 2.00 | 133.1 | 153.3 | 124 | 162.5 | 2 | 1 | 5S-HTA022UDB |
| 153.6 | 67 | 2.17 | 143.3 | 163.4 | 134 | 172.5 | 2 | 1 | 5S-HTA024UDB |
| 170.8 | 108 | 3.13 | 156.4 | 181.6 | 144 | 192.5 | 2 | 1 | 5S-HTA026UDB |