

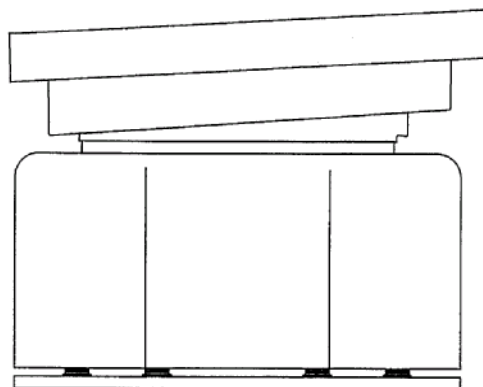

INSTRUCTION MANUAL

NTN Bowl Feeder G50/G63

Before Use
Read the Instruction Manual to the last ,
and operate the machine correctly.



Introduction

Thank you for your purchase of the **NTN** Bowl Feeder. For correct operation of the bowl feeder, read the Instruction Manual carefully before use, and ensure execution of safe work through correct operation.

Be sure to deliver this Instruction Manual to the end user. User is requested to store the Instruction Manual carefully to be able to read it again any time soon after reading.

1. Before Use











- When this machine is delivered to you, please check if there is any damage or part missing during transportation. If any defect is found, please contact to the nearest sales office.
- If fixtures for packing and transportation are mounted on the machine, be sure to remove the fixtures before use.
- Be sure to use **NTN** controller and bowl for the machine. When controller and bowl used are other than those of **NTN**, the specified performance of the machine may not be obtained.

Contents

	Page
Introduction	1
1. Before use	1
2. Precaution for safety	2~3
3. Operating principles	4
4. Main structure and names	4
5. Dimensional drawing	5
6. Transportation and installation	6
7. Wiring and running methods	7~8
8. Inspection and adjustment	8~11
9. Troubleshooting	12
10. Specifications	13~14

2. Precaution for Safety

This machine is designed and manufactured as a part feeder based on the concept of trouble free and laborsaving. However, a user of the machine also has an important responsibility for safety. Be sure to read this Instruction Manual carefully before use, and to strictly observe the following safety instructions as well as warning and caution labels adhered to the body.

 WARNING	Indicates a potentially hazardous situation which, if not avoided, will result in death or serious injury.
 CAUTION	Indicates a potentially hazardous situation which, if not avoided, will results in injury or property damage only.
 WARNING	
	Electric equipments have highest risk on danger. Be sure to connect a grounding cable. Electric shock may be caused, unless this machine in grounded.
	Do not use the machine where flammable gas exists. Explosion or fire hazard may be caused.
 CAUTION	
	Do not use the machine in a place exposed to splash of water, outdoors, or in a place of extremely low temperature or high temperature and high humidity. (Refer the next page for environment conditions for use)
	<ul style="list-style-type: none"> • This machine is heavy (Refer the spec. of clause 10 for weight). When transporting the machine, be sure to wear safety shoes and take care not to drop the machine. • Be sure to fix the machine securely after installation.
	<ul style="list-style-type: none"> • Be careful not to work touching with bare hands during installation and assembly. • Not to touch the sharp edge of the bowl equipped with attachment with bare hands. <u>Wear protective gloves without fail.</u>
	Do not use the machine on a base with insufficient strength or in an unstable place. The specified performance of the machine may not be ensured.
	Do not install the body in inclination. The specified performance of the machine may not be ensured.
	Please do not scratch, pull or forcibly bend the wiring. Moreover, when a heavy thing is put on it, or it is pinched, the wiring will damage. It causes a fire or an electric shock.
	When welding to the bowl, be sure to connect the grounding clip of the welding machine to the bowl securely. If grounding for welding is incomplete, the grounding wire connecting the body to the controller will burn, possibly resulting in electric shock or electric leakage.

□ For correct use

- (1) **NTNBowl feeder** is a vibrating machine equipped with a function of aligning the direction of specified parts in the bowl, which lines up and transfers parts in bulk. Do not use the machine for other purposes, e.g. equipments for material test and vibrating screen.
- (2) Operate the **NTN bowl feeder** in accordance with instructions given in this Instruction Manual. Refer to paragraph 10 for the engineering specifications.
- (3) Be sure to use **NTNController and Bowl** for this machine. Also use controller, bowl and power source conforming to this machine.
- (4) Generated noise level differs depending upon the machine specifications and parts transferred. If the noise level exceeds a permissible limit, implement noise proofing measures e.g. use of sound proof cover.

(Note 1) When the machine is not in perfect condition (abnormal noise, abnormal vibration and part missing etc.), do not use the machine.

(Note 2) In case that the aligning mechanism to line up the specified parts is equipped with the bowl, parts other than specified ones are not allowed to be loaded.

(Note 3) Environment condition for use

Ambient temperature	0~40°C
Ambient humidity	30~90% (No condensation allowed)
Height	Max. 2000m
Storage temperature during transportation	-10~50°C
Ambient atmosphere at place of use	Not exposed to splash of water, chemicals etc.. Flammable gas and corrosive gas are not allowed. Must be used indoor.

□ Compliance items of user

- (1) Be sure to follow this Instruction Manual during any work such as operation, maintenance and repair etc.
- (2) Be sure to avoid the use which may affect safety of **NTN Bowl feeder**. When any sign affecting safety is found, report the content to **NTN**.

(Note) Installation, operation, maintenance and repair of **NTN Bowl feeder** must be conducted by professional engineer(s). Be sure to avoid the operation by person other than ones concerned.

3. Operating Principles

NTN bowl feeder has the bowl connected to the lower vibrator by means of the leaf spring provided with a certain angle, and the bowl is rotated and vibrated with a magnet, so that works in the bowl are thrown upward aslant, resulting in little by little advancement. The relation between the bowl and the leaf spring is so set that resonance may be nearly achieved to the suction frequency of the magnet. As a result, large vibrations can be generated with a small exciting force.

4. Names of Main Component Parts

K-G50

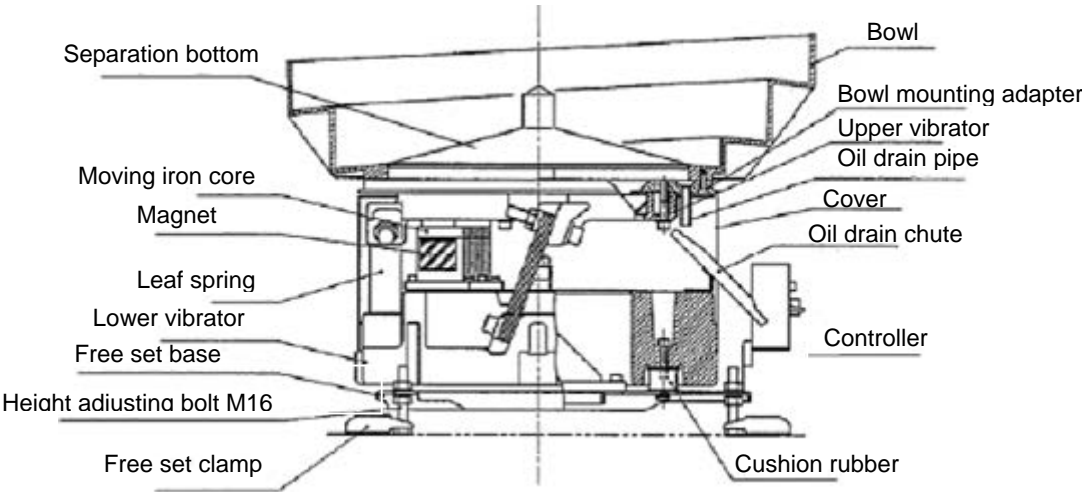

K-G63

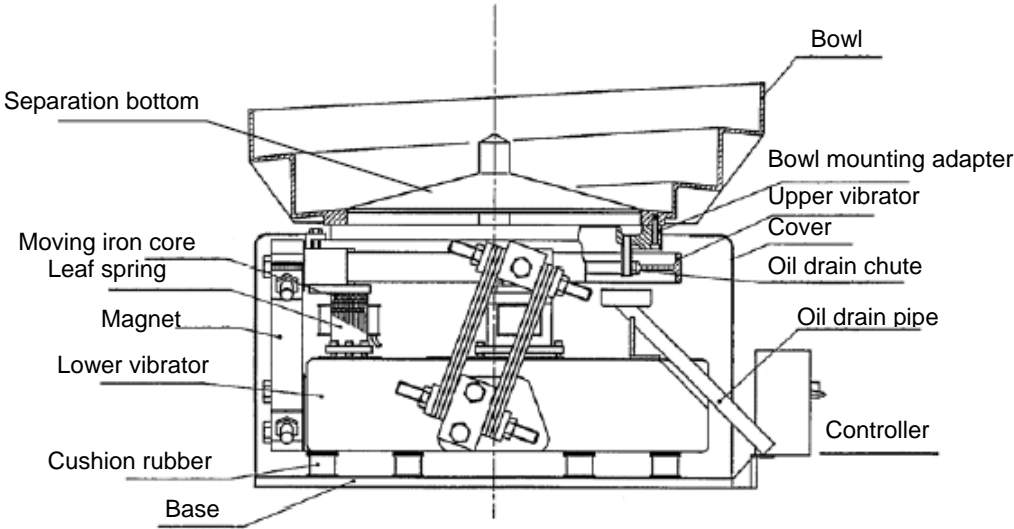

(Note) The shapes of the bowl and the controller may be different from those shown above.

5. Dimensional Drawing

K-G50 ^R _L 1M4	K-G50 ^R _L 1G4	K-G50 ^R _L 1T4
<p>4-M12 oblong hole (±3°) P.C. D400 3-Hexagon head bolt M16 Bowl mounting surface (φ575) φ440^{-0.1} (φ580) 325 (395±20) 70±20 P.C. D 400 P.C. D 1610 φ640 6-M10 Cushion rubber mounting 3-φ17 Controller Free setting base dimensional drawing (Top view)</p>	<p>12-φ9 P.C. D525 3-Hexagon head bolt M16 Bowl mounting surface (φ575) (φ541) 20 325 (345) (415±20) 70±20</p>	<p>12-φ9 P.C. D525 3-Hexagon head bolt M16 Bowl mounting surface (φ575) (φ541) 25 345 (415±20) 565~605 70±20</p>
K-G63 ^R _L 2M4	K-G63 ^R _L 2G4	K-G63 ^R _L 2T4
<p>8-Hexagon head bolt M10 Bowl fixture Bowl mounting mounting surface 4-M10 tapping through φ780 488 488 Controller Base dimensional drawing (top view)</p>	<p>12-φ9 tapping through P.C. D525 Bowl mounting adapter mounting surface φ534 780 (110) (324) 780 16 388 428</p>	<p>Oil drain chute φ25 φ475 25 428 560~570</p>

6. Transportation and Installation

CAUTION

This machine is heavy. Be sure to work carefully with the hoisting accessory or the like as shown below for transportation. Falling may lead to a serious accident.

(1) Transportation

Remove the bowl (with adapter) and the separation bottom, set a wire rope, a nylon slinger or the like on the upper vibrator, and lift the vibrating body for transportation.

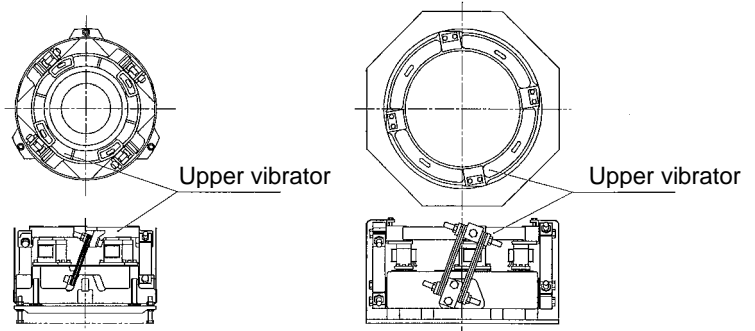

□ Precautions for transportation

- (1) Use a lifting device and a hoisting accessory of sufficient lifting capacity in considerations of individual body masses (in the case of a type provided with a bowl, the bowl mass should be added). Refer to the specifications of paragraph 10 for the body weight.
- (2) Be sure not to place hands and foot under the lifted body during transportation.
- (3) Do not move the body holding it.

(2) Installation

Fix the machine securely with the base free set clamps (3 places) or by making use of the tapped holes (4 places).

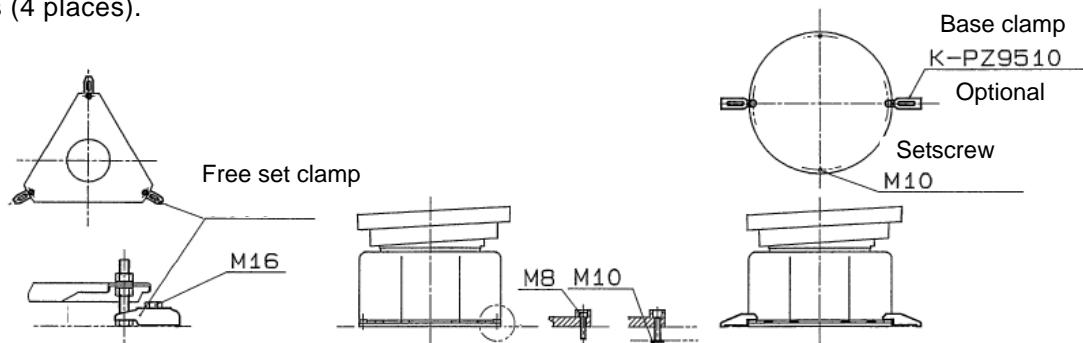

□ Precautions for installation

- (1) Conduct assembly and setting with sufficient care taken for deformation of the bowl and the attachment.
- (2) Wear protective gloves so that the bare hands may not touch with the sharp edge of the bowl attachment and others.
- (3) Do not use the machine on the base lacking in sufficient strength or in an unstable place.
- (4) Do not contact the vibrating body (except. the base) of the machine with others for fixing.
- (5) When this machine is installed in inclination, its specified performance may not be ensured. Be sure to check the levelness after installation.
- (6) When welding work or grinding work is intended in vicinity of the bowl feeder, be sure to fit the protection cover over the whole of the bowl feeder. Otherwise, iron powder may fly into the machine to spoil the performance.

7. Wiring and Operating Methods

WARNING

Ensure the source voltage as specified on the machine nameplate of the vibrating body (Type, power source and manufacturer's serial No. seal). Be sure to connect the grounding wire of the power source.

CAUTION

Ensure that the setting of each controller for the controller equipped with a selector switch (All wave/Half wave, 50Hz/60Hz, 100V/200V etc.) and the frequency variable controller equipped with a F-V curb setting are in accordance with the body specifications and the power source condition. Otherwise, an accident such as a magnet seizure may be caused. Refer to the Instruction Manual for the controller for the setting of the selector switch and the F-V curb.

G50

Controller
(Ex. K-ECH45)

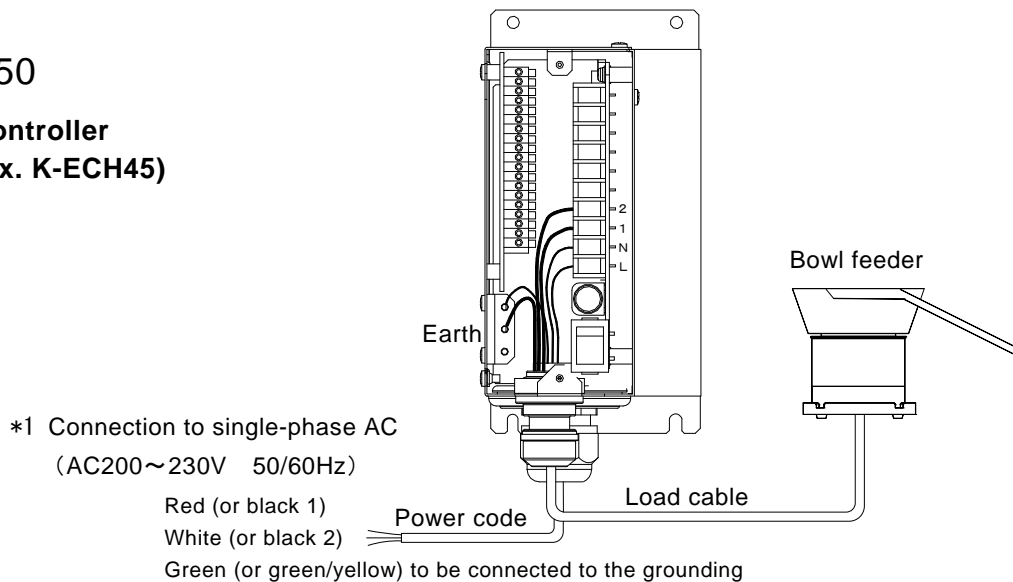

G63

Controller
(Ex. K-ECK96)

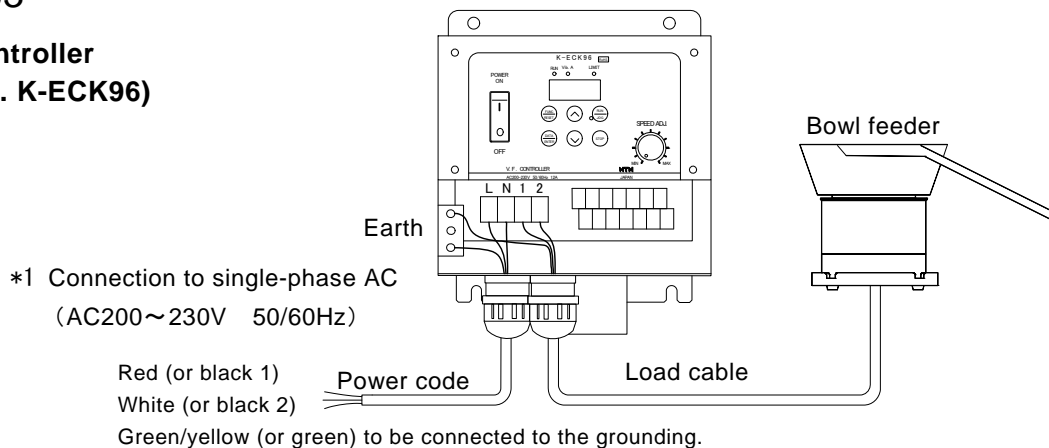

*1 In the case of 3-phase power supply, use two phases out of three. Do not use the remaining one phase.

- (1) When the chute and the bowl feeder are equipped with fixtures for transportation, remove those fixtures.
- (2) Connect the power source (Refer to the Instruction Manual of the controller for the detailed wiring method).
- (3) Turn the SPEED ADJ volume counterclockwise up to the position of scale "0".
(Make sure that the bowl feeder is not in contact with anything and is in free condition)
- (4) Load parts into the bowl and turn ON the POWER switch of the controller. (Confirm lighting of LED on the operation panel.)
- (5) Turn the speed adjusting knob of the controller slowly clockwise to set the graduation at a workpiece speed that matches with supply capacity. Operate this machine under the maximum acceptable amplitude of leaf spring in the item 8 in order to prevent breakage of leaf spring.

(Note 1) When assembly is intended with an equipment, Do not open and close on the primary side of the controller for "ON-OFF". Use the external control input terminals for "ON-OFF".

(Note 2) Connection work of the power source must be conducted by an electrical engineer. Refer to the Instruction Manual for the controller for modification or alteration of wiring.

(Note 3) When the bowl is equipped with an attachment, and the indication mark is provided on the speed adjustment volume of the controller, set the adjustment volume to that position for use.

(Note 4) When the loading wire is extended by your company, make sure that the wire size must be more than 2.5mm² and its length must be less than 10m. Further more, conduct the electric continuity test and confirm if the grounding is properly connected.

(Note 5) Refer to the Instruction Manual for the controller for the controller used.

8. Inspection and Adjustment

(1) Inspection and adjustment of leaf springs

① Max. allowable amplitude of leaf spring

Operate the machine under an amplitude as shown in the table below to prevent break of the leaf spring. When the machine is operated at an amplitude larger than the value shown, the leaf spring may possibly break at an early time. When the amplitude is measured, adhere the supplied amplitude marks as shown below, and be sure to sum the readings of the upper and the lower amplitude marks.

Type · size	Leaf spring part No.	Amplitude(mm) (upper area + lower area)
G50 · 1	K-PLS2-180×40	3.3
G63 · 2	K-PLS2-250×70	3.6

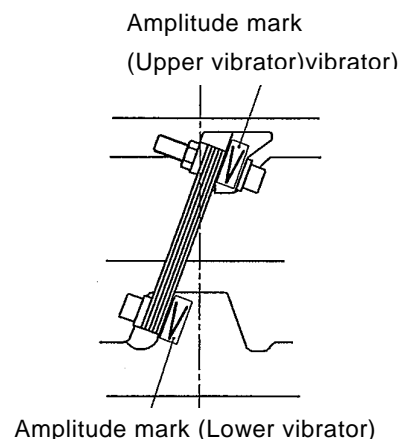

(Note) When a recommended speed is designated by NTN, adjust the volume position to the recommended scale.

② Precautions for attachment/detachment of leaf spring

When attaching or detaching leaf springs, be sure to finish the attaching or detaching work of one unit before going to the next unit. Never loosen springs of all units at the same time.

- a) Change the bolt length according to the increase or decrease in the number of springs on assumption that the required bolt bite length (dimension L) is at least 2 times as large as the screw diameter.

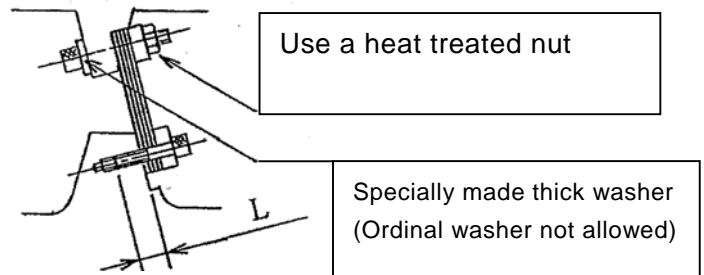

- b) Place spacers between leaf springs, and apply grease or rust preventative oil between the spring and the spacer. At that time, make sure not to include dirt and chips between them.

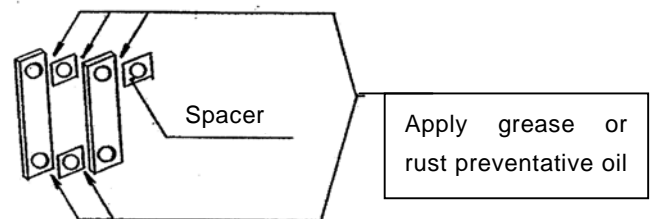

- c) Tighten leaf springs securely at guideline torque shown below. After the completion of leaf spring adjustment, apply grease or rust preventative oil to the whole part of leaf spring. At the time of tightening, be sure that directions of spacers are aligned with ones of leaf springs.

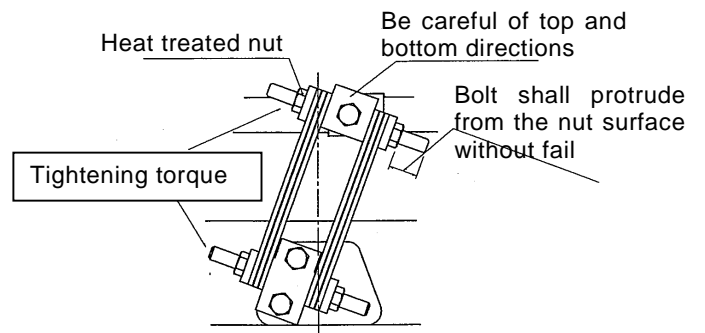

Type · Size	Bolt	Tightening torque	Remarks
G50 · 1	Hexagon socket head bolt M18 (Strength grade :12.9 or more)	Approx.400N·m (Approx.4100 kg f·cm)	Under full power of one hand using tool with arm length of 500mm
G63 · 2	* 1 Leaf spring tightening bolt M20	Approx. 490N·m (Approx. 5000 kg f·cm)	Under full power of one hand using tool with arm length of 600mm

* 1 When the leaf spring tightening bolt is newly required, contact NTN.

③ Retightening

Check the leaf spring tightening bolts after actual operation for approx. 40 hours, and retighten the bolts.

When the bolts have been tightened to normal torque, there is hardly allowance for additional tightening, but consider this requirement as retightening to ensure comfortable fitting of leaf springs.

④ Correction of set in fatigue

When the SPEED ADJ. volume comes to be used at the max. position at all time, add one or two pieces of leaf springs to any one place of the leaf spring unit.

Even if the leaf spring tap bolts are fastened normally, the amplitude may decrease negligibly owing to the repetitive stress resulting from vibration after the machine is run for 40 to 100 hours.

⑤ Replacement of leaf springs

Replacement of all leaf springs is recommended after run of the machine for one year on the basis of 8 hour run a day as a guideline.

If the amplitude can not be recovered even after correction of set in fatigue in the paragraph ④ above, it is considered that the leaf springs have been reached the end of life. 100% replacement of leaf springs is recommended.

(Note) When new springs are required, purchase them while referring to the “Leaf spring part No.” in the Specification of paragraph 10.

(2) Adjustment of magnet clearance

The clearance between the magnet and the moving iron core is set to the value as table below at the shipment of the main body from **NTN**. But, the narrowest possible clearance within the range not to get in touch with the magnet at the max. amplitude is advisable. Check the magnet clearance from time to time to keep a correct value of clearance.

Further, in the atmosphere where lots of powders exist, they will adhere in solid form to the magnet resulting in reducing the clearance and may cause unusual noise.

Accordingly, inspect the magnet periodically and remove such fouling.

Type · Drive system	Magnet clearance (mm)	
	At shipment	Max.
G50·1 (Half wave)	0.6	
G63·2 (Half wave)	0.65	

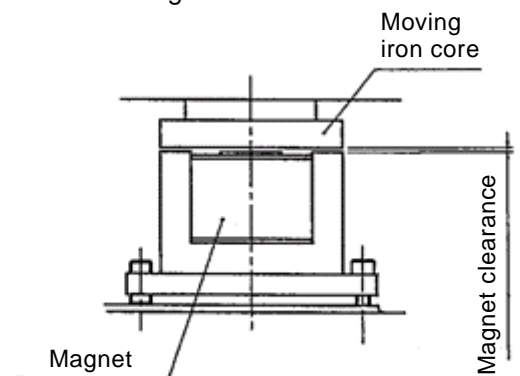

(Method of adjustment)

- ① Remove the cover
- ② Insert the clearance gauge with specified dimension on each main body (see the table above) into the magnet clearance, and loose 3 hexagon socket head bolts locking the magnet, then adjust the clearance between the magnet and the moving iron core by adjusting 3 hexagon socket head set screws upward and downward.
- ③ Fasten magnet locking bolts (Hexagon socket head bolt: 3 pieces). Take care not to misalign the setting position of ②.
- ④ Pull out the clearance gauge (Make sure that there is no misalignment in magnet clearance)
- ⑤ Fix the cover

⚠ Caution

If magnet clearance exceeding 1.2 times of max. value shown above is used, the magnet may break. Check the clearance from time to time and maintain the correct value of clearance.

(3) Change of power frequency

NTN bowl feeder is adjusted in conformance with power frequency in the region where it is used, or the set frequency of the controller. Accordingly, the machine does not vibrate correctly, if the power frequency or the set frequency of the controller as the driving output frequency is changed. To change the power frequency, follow the procedure given below.

(Note) In case that the driving output frequency is set by the frequency variable controller, the change of set is not required even if the power frequency (50Hz↔60Hz) is changed.

① Change of number of leaf springs

50Hz→60Hz : Increase the number of leaf springs by approx. 40%

60Hz→50Hz : Decrease the number of leaf springs by approx. 30%

(Reference : How to check excess or deficiency of number of leaf springs)

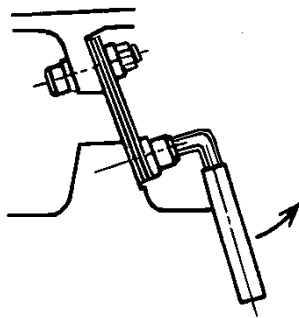

To check if the number of leaf springs currently provided with the machine is excess or deficiency for the bowl and the attachment, follow the procedure given below.

Loose slightly the leaf spring locking bolt only at one place while vibrating it, and check the amplitude.

- Amplitude increased→Excess of number of springs
- Amplitude decreased→Deficiency of number of leaf springs or be appropriate

If sufficient amplitude is provided, and it decreases when the bolt is loosen, it is in the best condition.

② Changeover of the frequency in the controller

Conduct setting as shown on the table below. For further details, refer to the Instruction Manual for each controller.

Power source frequency	In the case of 50Hz		In the case of 60Hz	
	SW2	ON	SW2	OFF
	SW3	OFF	SW3	ON
Setting of DIP switch by K-EGA57.				

9. Troubleshooting

If a trouble should take place, check the following points.

(1) No vibration at all

In this case, conduct checking after dividing the trouble contents into those of the mechanical system and the electric system. Turn ON the power switch and remove the cover, then bring iron pieces close to the magnet core as shown below.

① Strong suction in swing of all iron pieces by magnet :

The electric system is normal. This trouble is because of either one of wrong setting of the number of bowl feeder leaf springs or wrong designation of the frequency.

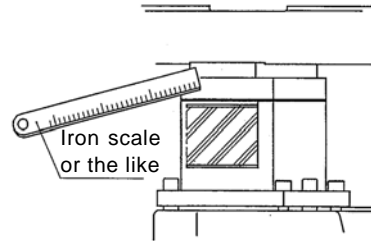

② Not sucked at all :

The trouble is because of the electric system including the controller and the magnet. But, when the controller used is equipped with a sensor, a possible cause may be detection of works by the detecting head. This is not a failure. Align the optical axis and reconfirm the proximity distance and others.

Concerning the electric system, check the following points for sake of confirmation.

- a) Correct connection of the power source (See “Wiring and operating methods” of paragraph 7)
- b) Fusion of the controller fuse and working of the over current protective function.
- c) Shorting of the controller external control signal input terminals. Closing of the terminals according to external control signal (refer to the Controller Instruction Manual.)
- d) Magnets are all normal (When a-c are normal, conduct the suction test shown above on each magnet)

(2) Vibration is available but amplitude is insufficient

- ① Improper power source (connection of 100V to 200V specifications)
- ② Loosening of leaf spring mounting bolt
- ③ Loosening of locking bolt of bowl and others
- ④ Excessively wide magnet clearance
- ⑤ Omission of removal of fixtures used for transportation

(3) Gradual decrease of amplitude during use

- ① Set in fatigue of leaf spring
- ② Loosening of leaf spring mounting bolt
- ③ Break or rusting of leaf spring
- ④ Inclusion of iron powder and others in magnet clearance
- ⑤ Loosening of bowl locking bolt

(4) Unusual metallic noise

- ① Excessively narrow magnet clearance, or inclusion of foreign matter
- ② Excessive amplitude
- ③ Interference of the cover with the vibrator
- ④ Omission of removal of fixtures used for transportation

When the cause can not be located, inform us of the symptom as in detail as possible to facilitate quick establishment of countermeasures while referring to those described above.

10. Specifications

K - G 50 ^R/_L 1 M 4

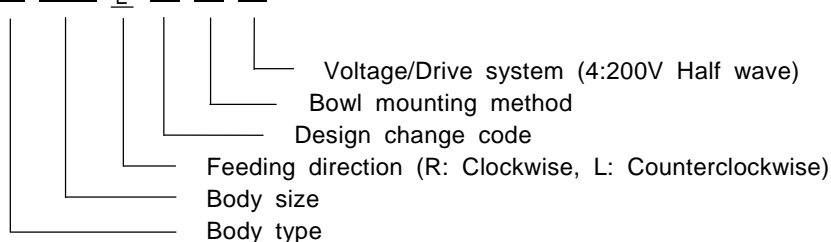

Product No.	K-G50 ^R / _L 1M4	K-G50 ^R / _L 1G4	K-G50 ^R / _L 1T4
Bowl mounting method	Basic type (without separation bottom & adapter)	With bowl mounting adapter	Separation bottom (With oil drain chute)
Source voltage (V)	200		
Consumption current(A)	4.0		
Power consumption(VA)	800		
Drive system	Half wave		
Frequency (times/min.)	3000(50Hz), 3600(60Hz)		
Leaf spring angle (θ°)	20°		
Max. loading weight(Kg) (Work+Bowl weight)	60		
Magnet part No. (Qty. used)	K-PMG-521-1 (2 p.c.s.)		
Cable size × length (from center)	Magnet : 1.5m ^m ×1.15m Body : 1.5m ^m ×1.35m		
Leaf spring assy. (Number of places)	4		
Number of leaf springs for standard set	5 p.c.s.×4 places=20 p.c.s.		
Leaf spring part No. (Material)	K-PLS2-180×40 (Steel)		
Leaf spring dimension (mm) Length (Hole pitch) × Width × Plate thickness	215(180)×50×4		
Strength grade of leaf spring mounting bolt	12.9		
Leaf spring tightening torque	400N·m (4100k g f·c m)		
External paint color	Black/Silver		
Weight (kg)	185	190	220

(Note) Refer to Catalog and the Instruction Manual of the controller for applicable controller to this machine

K - G 6 3 _L ^R 2 M 4

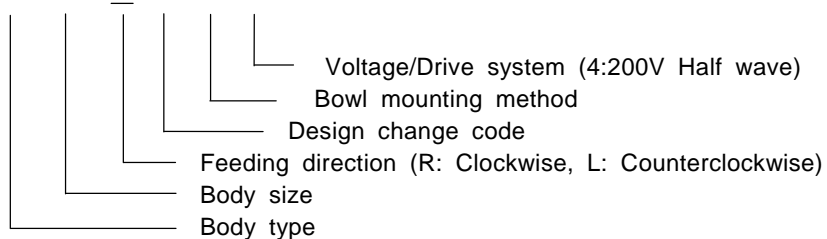

Product No.	K-G63 _L ^R 2M4	K-G63 _L ^R 2G4	K-G63 _L ^R 2T4
Bowl mounting method	Basic type (without separation bottom & adapter)	With bowl mounting adapter	Separation bottom (With oil drain chute)
Source voltage (V)	200		
Consumption current(A)	10.0		
Power consumption(VA)	2000		
Drive system	Half wave		
Frequency (times/min.)	3000(50Hz), 3600(60Hz)		
Leaf spring angle (θ°)	20°		
Max. loading weight(Kg) (Work+Bowl weight)	75		
Magnet part No. (Qty. used)	K-PMG-521 (4 p.c.s.)		
Cable size × length (from center)	Magnet : 2.5mm ² ×1.15m Body : 2.5mm ² ×1.7m		
Leaf spring assy. (Number of places)	4		
Number of leaf springs for standard set	4 p.c.s.×4 places=16 p.c.s.		
Leaf spring part No. (Material)	K-PLS2-250×70 (Steel)		
Leaf spring dimension (mm) Length (Hole pitch) × Width × Plate thickness	300(250)×50×7		
Strength grade of leaf spring mounting bolt	—		
Leaf spring tightening torque	490 N · m (5000 K g f · c m)		
External paint color	Black/Silver		
Weight (kg)	360	370	400

(Note) Refer to Catalog and the Instruction Manual of the controller for applicable controller to this machine

【Memorandum】

Warranty for NTN Part Feeder

Shipment warranty is attached with this product. Please receive it without fail at the time of purchase. It is to assure you the product repair in free of charge according to the warranty conditions stipulated on the warranty. You are required to store it carefully after reading the content.

- The content of this Instruction Manual is subject to change without prior notice due to functional improvement.

Published: Jan. 17, 2013 5th edition

NTN Corporation

Precision Equipment Division
1578 Higashi-Kaizuka, Iwata, Shizuoka 438-8510, Japan
PHONE: 81-538-37-8104, FAX: 81-538-37-8128

All rights reserved ©NTN Corporation 2013