





1. Design features and characteristics

The **NTN** plumber blocks are housings for self-aligning ball bearings and spherical roller bearings. The standard housing is gray cast iron, while spheroidal graphite cast iron (ductile cast iron) and cast steel, are also available depending on the application.







The housings can incorporate rubber seals, felt seals, or labyrinth seals depending on the application. Grease and oil are both available for lubrication.

This catalog includes dimension tables of representative shapes indicated by blue characters in "2. Type."

For the details on **NTN** plumber blocks, see the special catalog "PLUMMER BLOCKS (CAT. No. 2500/E)."

Plummer block types		Shaft diameter mm	Page of dimension table
Split type	SN type 	25 to 140	G-14 to G-25, G-30 to G-31
	SD type 	150 to 300	G-26 to G-29, G-32 to G-35
	SBG type 	55 to 180	—
Unit type	SV type 	20 to 300	G-36 to G-43
	VA type 	50 to 100	—

2. Type

Type	Type
<p>SN type (standard type, large bore type) SN5 SN2 SN6 SN3 S6 S3 SN30 SN31</p>  <p>Lubricant: grease Seal: rubber seal • SN5, SN6, and S6 are general types and widely used internationally. • SN30 and SN31 are a medium size and can be applied when the bearing diameter is large. • A tapered bore bearing (with adapter) is used.</p>	<p>SD type (stepped bore type for heavy loads) SD2··(G) SD3··(G) SD35··(G) SD36··(G)</p>  <p>Lubricant: grease or oil Seal: double rubber seal • Used for heavy loads with large spherical roller bearings. • This type of plumber block is SD5(G) and SD6(G) having a large aperture on one side. • Cylindrical bore bearings are attached with nuts and washers.</p>
<p>SNZ type (stepped bore type) SNZ2 SNZ3 SZ3</p>  <p>Lubricant: grease Seal: rubber seal • This type of plumber block is SN5, SN6, and S6 having a large aperture on one side. • Cylindrical bore bearings are attached with nuts and washers.</p>	<p>SD type (labyrinth seal type) SD31··TS(G) SD32··TS(G)</p>  <p>Lubricant: grease or oil Seal: Labyrinth seal • Used for heavy loads with large spherical roller bearings. • Suitable for high speed rotation because the sealing device for labyrinth seals is adopted. • Used for both oil lubrication and grease lubrication because an oil sump is provided in the housing.</p>
<p>SN type (high strength type) SN5··F SN2··F SNZ2··F SN6··F SN3··F</p>  <p>Lubricant: grease Seal: rubber seal • The recess at the bottom part is made small and the leg is made flat at the bottom to increase the strength of the plumber block. • The dimensions are the same as the same series except for the bottom shape. • A tapered bore bearing (with adapter) is used. • There is no mounting bolt hole.</p>	<p>SV type (standard type) SV5 SV6 SV30</p>  <p>Lubricant: grease Seal: rubber seal • The plumber block main body is a single type and has higher accuracy compared with the split type. • A tapered bore bearing (with adapter) is used. • SV30 is a medium type applied when the shaft diameter is large.</p>
<p>SD type (standard type for heavy loads, large bore type) SD5··(G) SD2··D(G) SD6··(G) SD3··D(G) SD30··(G) SD31··(G) SD33··(G) SD34··(G)</p>  <p>Lubricant: grease or oil Seal: double rubber seal • Used for heavy loads with large spherical roller bearings. • There are types for the floating side and the fixed side (G). • A tapered bore bearing (with adapter) is used. • There are four mounting bolt holes.</p>	<p>SV type (stepped bore type) SV2 SV3 SV35</p>  <p>Lubricant: grease Seal: rubber seal • This type of plumber block is SV5 and SV6 having a large aperture on one side. • Cylindrical bore bearings are attached with nuts and washers.</p>
	<p>VA type (narrow attachment width type) VA5</p>  <p>Lubricant: grease Seal: oil seal • A tapered bore bearing (with adapter) is used. • Mounting bolt holes are provided at the bottom.</p>

3. Plummer block numbers

NTN plummer block number indicates the type, structure, and consists of basic numbers followed by supplementary codes.

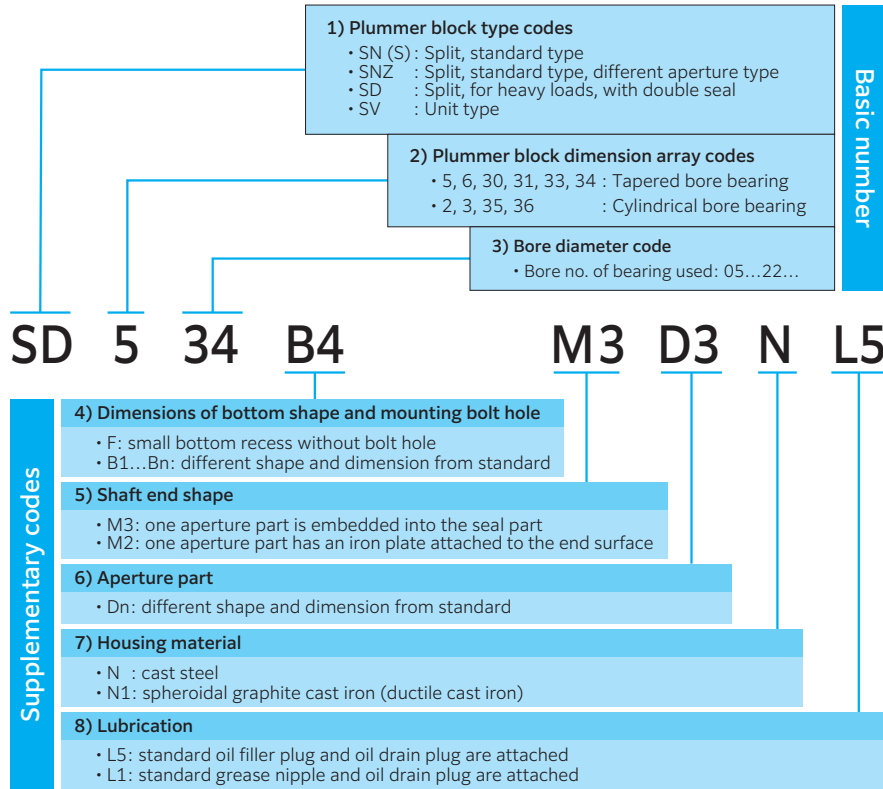

For order
The plummer block numbers do not include additional parts. Therefore, please order any necessary parts with their numbers.
(Example)

SN506	1206SK	H206X	SR62×7	ZF6
Plummer blocks	Rolling bearings	Adapter	Positioning wheel (fixed side only)	Rubber seal

Article
For shaft ends, a plummer block having a non-penetrating aperture on the shaft end side (outer side) is generally used. There are two types shown below.

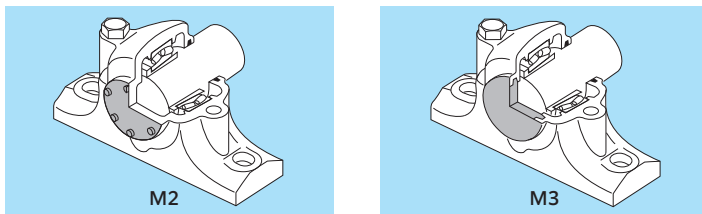

4. Accuracy

4.1 Accuracy

Regarding the accuracy of NTN plummer blocks, the divided types conform to JIS B 1551 and the single types to The Japan Bearing Industrial Association (BAS) 188. The dimensional tolerances are shown in the table below.

Table 1: dimensional tolerances of bearing seating bore diameter, width, and center height

Table 2: dimensional tolerances of length of gray cast iron products (As cast portions on bearing base, bolt holes, etc)

Table 1 Dimensional tolerance of plummer blocks

Unit: mm

Plummer block series	Split type			Unit type					
	Bearing seating bore dia. Δ_{Ds}	Bearing seating bore width Δ_{gs}	Center height Δ_{Hs}	Plummer block series	Bearing seating bore dia. Δ_{Ds}	Center height Δ_{Hs}	Main body width I_1	Cover dimension I_2	Cover inlet width I_3
SN5, SN5F SN(S)6, SN(S)6F SN2, SNZ2, SN30 SN(S)3, SNZ(SZ)3, SN31 SBG5	H8	H13	h13	SV5 SV6 SV2 SV3 SV30 SV35 VA5	H7	h11	+0.2 0	±1	0 -0.2
SD30, SD31 SD33 SD34, SD35 SD36 SD2, SD3 SD5, SD6 SD31TS, SD32TS	H8	±0.2	h13						

Table 2 Dimensional tolerance of length of gray cast iron products

Unit: mm

Length of gray cast iron products	120 or less	121 to 250	251 to 400	401 to 800	801 to 1 600
Tolerance	±1.5	±2.0	±3.0	±4.0	±6.0

4.2 Machining accuracy of mounting bolt seating end surface

When a large horizontal load is to be applied on a plumber block, the fastening force of the mounting bolts cannot reliably secure the plumber block alone; therefore, the housing base should abut a fixed surface. In this case, it is effective to use a plumber block with a

machined vertical face that comes in contact with the fixed abutment surface.

Seating length L of a plumber block having a machined mounting bolt seating end surface is smaller than the standard dimension by the machining allowance shown in **Table 3** and becomes L' (see **Fig. 1**). **Table 4** shows the dimensional tolerance of L' .

Table 3 Machining allowance Unit: mm

Plummer block nominal dimension	Machining allowance $L-L'$	Surface finish roughness
All types All sizes	5	12.5Ra

Table 4 Tolerance of dimension L' after machining of mounting bolt seating end surface Unit: mm

Dimension after machining L'	31 to 120	121 to 315	316 to 1 000	1 001 to 2 000
Tolerance	±0.8	±1.2	±2.0	±3.0

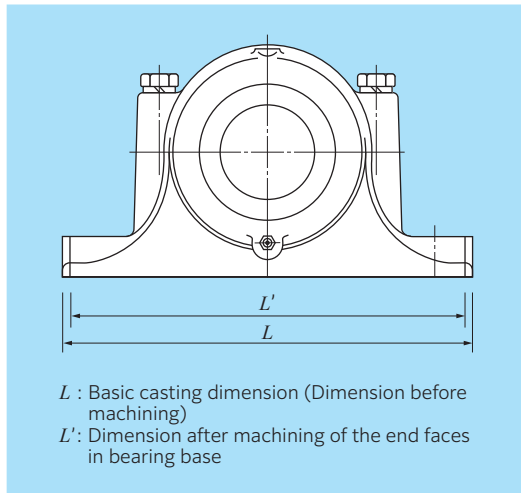

Fig. 1 Seating surface length dimension of plumber block

5. Combination with bearings

Table 5 (1) and **Table 5 (2)** show the combinations of plumber blocks and bearings.

Table 5 (1) Plummer blocks and applied bearings

Plummer block series \ Applied bearing series	12	22	13	23	230	231	222	232	213	223
SN5 SN5·F	06SK to 22SK	06SK to 22SK					06EAK to 32EAK	18EMK, 20EMK to 32EMK		
SN2 SN2·F	06S to 22S	06S to 22S					06EA to 32EA	18EM, 20EM to 32EM		
SNZ2 SNZ2·F	06S to 22S	06S to 22S					06EA to 32EA	18EM, 20EM to 32EM		
SD5 SD5·G							34EMK to 64EMK			
SD2·D SD2·DG							34EM to 64EM			
SD2 SD2·G							34EM to 64EM			
SN(S)6 SN(S)6·F			06SK to 22SK	06SK to 22SK					08CK to 10CK 11K to 22K	08EAK to 28EAK 30EMK to 32EMK
SN(S)3 SN(S)3·F			06S to 22S	06S to 22S					08C to 10C 11 to 22	08EA to 28EA 30EM to 32EM
SNZ(SZ)3 SNZ(SZ)3·F			06S to 22S	06S to 22S					08C to 10C 11 to 22	08EA to 28EA 30EM to 32EM
SD6 SD6·G										34EMK to 56EMK
SD3·D SD3·DG										34EM to 56EM
SD3 SD3·G										34EM to 56EM
SN30						24EAK to 38EAK				
SD30 SD30·G						34EAK to 38EAK 40EMK to 76EMK 80BK to 96BK				
SD33 SD33·G						40EMK to 76EMK				
SD35 SD35·G						40EM to 76EM				
SN31							22EAK to 36EAK 38EMK			
SD31 SD31·G							34EAK to 36EAK 38EMK to 68EMK 72BK to 84BK			
SD34 SD34·G							40EMK to 68EMK			
SD36 SD36·G							40EM to 68EM			

Table 5 (2) Plummer blocks and applied bearings

Applied bearing series Plummer block series	12	22	13	23	230	231	222	232	213	223
SD31··TS SD31··TSG						34EAK to 36EAK 38EMK to 68EMK 72BK to 89BK				
SD32··TS SD32··TSG							34EMK to 64EMK 68BK to 80BK			
SBG5							12EAK to 32EAK 34EMK to 40EMK			
SV5	05SK to 22SK	05SK to 22SK				05EAK to 32EAK 34EMK to 64EMK	18EMK, 20EMK to 64EMK			
SV2	05S to 22S	05S to 22S				05EA to 32EA 34EM to 64EM	18EM, 20EM to 38EM			
SV6		05SK to 22SK	05SK to 22SK					08CK to 10CK 11K to 22K	08EAK to 28EAK 30EMK to 58EMK	
SV3		05S to 22S	05S to 22S					08C to 10C 11 to 22	08EA to 28EA 30EM to 58EM	
SV30					22EAK to 38EAK 40EMK to 72EMK					
SV35					22EA to 38EA 40EM to 72EM					
VA5							11EAK to 22EAK			
TV5							11EAK to 32EAK			

6. Allowable speed

The allowable speed of plummer blocks differ by seal types. In the case of a contact seal, the allowable speed is restricted by the allowable

peripheral speed of the seal. Fig. 2 shows a rough standard for selecting the peripheral speed of seals.

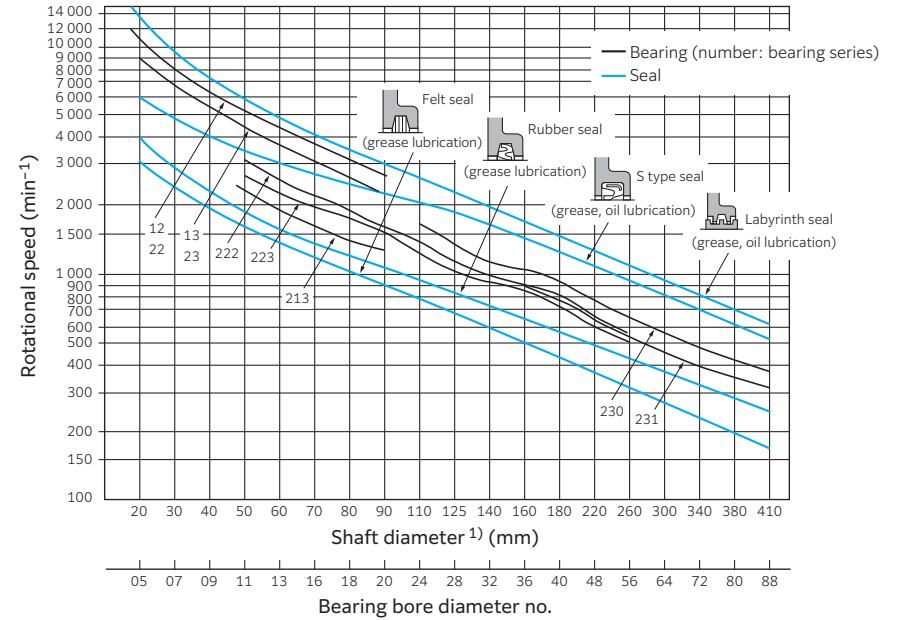

1) The allowable speed of the seal of cylindrical bore bearings is obtained by the shaft diameter of the seal contact part. The allowable speed of seals is indicated by the rotational speed of shafts.

Fig. 2 Allowable speed of bearings and seals

7. Sealing device

External seals have two main functions: to prevent lubrication from leaking out and to prevent dust, water, and other contaminants from entering the bearing.

The sealing device must be selected with the following in consideration: the type of lubricant (grease or oil) and seal peripheral speed.

A rubber seal or a felt seal is used for the contact type, and a labyrinth seal is used for the non-contact type. There are also special seals suitable for other conditions including heavy contamination.

7.1 Contact seal

(1) Rubber seal (see Fig. 3)

Since rubber seals are mainly used for grease lubrication, a rough standard for the peripheral speed is 5 to 6 m/s.

Nitrile rubber is generally used for the rubber seal material, and materials shown in **Table 6** are used depending on the ambient temperature.

(2) Felt seal (see Fig. 4)

Felt seals are interchangeable with rubber seals, but the use is limited to grease lubrication.

Felt seals are unsuitable for environments with a large amount of dust or high humidity, and a rough standard for the peripheral speed is 4 m/s. The seal is also convenient because it can be cut and embedded separately into the seal grooves at the upper and lower parts of a plummer block.

(3) S type seal (see Fig. 5)

The S type seal has excellent sealing performance and can be used for grease and oil lubrications. Plummer blocks with special specifications are used.

A rough standard for the peripheral speed of S type seals is 10 to 12 m/s. The shaft roughness and hardness of the seal contact area especially needs attention.

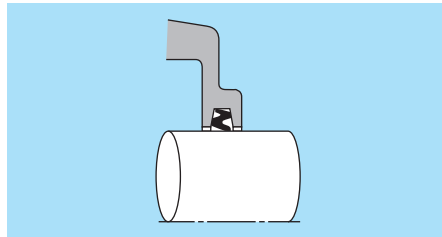

Fig. 3 Rubber seal

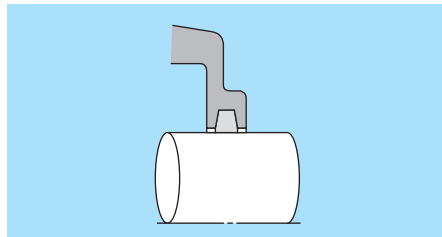

Fig. 4 Felt seal

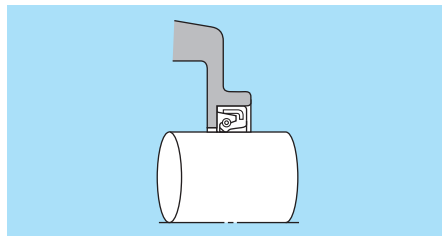

Fig. 5 S type seal

Table 6 Rubber seal materials types and characteristics

Seal material	Abrasion resistance	Oil resistance	Acid resistance	Alkali resistance	Water resistance	Allowable temp rough standard (°C)	Characteristics
Nitrile rubber (NBR)	◎	◎	○	○	○	-20 to 120	The material has resistance to most oils and has good abrasion resistance; therefore, it is the most used oil seal material. The material can be used for most conditions of general machines.
Acrylic rubber (ACM)	◎	◎	△	×	△	-15 to 150	The material has good heat resistance and oil resistance but poor alkali resistance and water resistance; therefore, the application is limited.
Silicone rubber (VMQ)	○	○	△	×	○	-30 to 200	The material has good heat resistance and cold resistance but cannot be used for spindle oil and oil containing an extreme pressure additive.
Fluorinated rubber (FKM)	◎	◎	◎	△	○	-20 to 230	The material is not affected by most oils and chemicals. The material has well-balanced characteristics and can be used in a wide range of applications; therefore, it is the best oil seal material.

◎ : Good, ○ : Fair, △ : Slightly poor, × : Poor (cannot be used)

7.2 Non-contact seal

(1) Labyrinth seal (see Fig. 6)

The labyrinth seal is a seal type that uses a labyrinth ring at the aperture part of a plummer block.

The labyrinth ring is used with a shaft loose fit (h9) and attached with an O ring to allow easy attachment and allow for expansion and contraction of the shaft.

The labyrinth seal has excellent sealing performance and can be used for grease and oil lubrications.

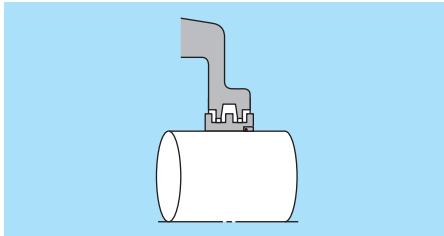

Fig. 6 Labyrinth seal

(2) Special labyrinth seal (see Fig. 7)

The special labyrinth seal shown in the figure is especially effective for environments with a large amount of contamination such as dirt and sand.

Plummer blocks using this seal have special specifications, so consult with NTN Engineering.

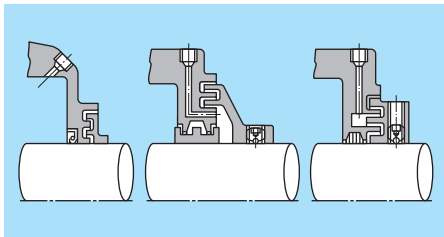

Fig. 7 Special labyrinth seal

(3) Shaft design criteria for seal attachment part (see Table 7)

The hardness and roughness of shafts to be attached with seal significantly influences the sealing performance; therefore, the design criteria shown in the table must be followed.

Table 7 Shaft design criteria

Item	Design criteria	Article
Hardness	HRC 30 to 40	
Roughness <i>Ra</i>	0.8	It is preferable to grind the finish surface without feeding.
End surface chamfer	The shaft end to be inserted with a seal must be tapered, and the corner part must be rounded.	15 to 30° Round the corner.

7.3 Combination seal (see Fig. 8)

The combination seal is a sealing device having a rubber seal and a labyrinth seal combined to the aperture part of a plummer block. It is used for environments with a large amount of dirt and foreign materials.

Filling the labyrinth voids with grease further improves the sealing effect.

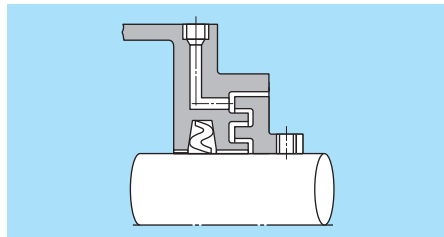

Fig. 8 Combination seal

8. Strength

The breaking strength of plummer blocks differ by the plummer block type, the characteristic and direction of the load to be applied, and is influenced by the flatness of the mounting surfaces. Fig. 9 and Fig. 10 shows the general fracture loads of static breaking strength of SN5 and SN6 (S6) series gray cast iron plummer blocks.

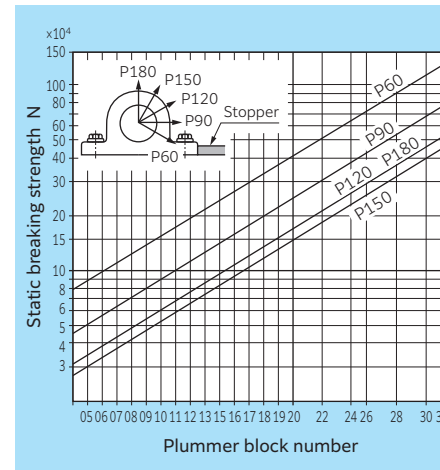

Fig. 9 Static breaking strength of SN5 series

The downward breaking strength is about twice the horizontal breaking strength, and the axial breaking strength is about half of the horizontal breaking strength.

When selecting plummer blocks, consider the safety factor shown in Table 8. The surface to be attached with a plummer block must be flat without backlash.

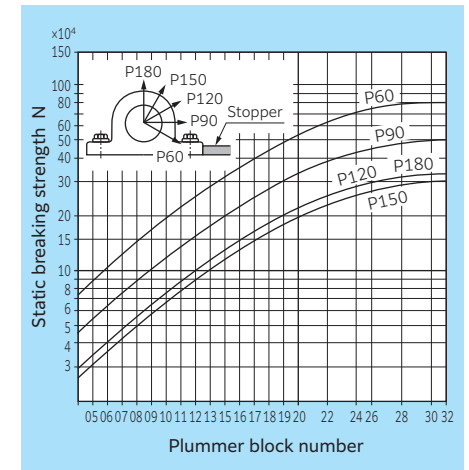

Fig. 10 Static breaking strength of SN6 (S6) series

Table 8 Safety factor of casting plummer block

Types of load	Static load	Repeated load	Alternating load	Impact load
Safety factor	4	6	10	15

For horizontal and axial loads, the base end surface needs to abut a fixed surface.

For places with especially large impact loads or when plummer block damage may result in serious accidents, plummer blocks made of materials other than gray cast iron such as cast steel or spheroidal graphite cast iron are available. Please consult NTN Engineering.

Plummer Blocks



Plummer block series SN5
(standard type / for bearings with adapter assembly)

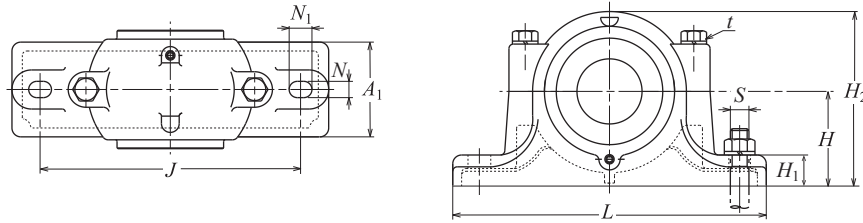

d₁ 25–140 mm

Shaft dia. mm	Plummer block number	Dimensions											Oil filler / drain plug size	Reference dimension S	Mass kg	
		mm														
d ₁	D	H	J	N	N ₁	A	L	A ₁	H ₁	H ₂	g	t	S	kg		
25	SN506	62	50	150	15	20	77	185	52	22	90	30	M 8	R1/8	M12	1.7
30	SN507	72	50	150	15	20	82	185	52	22	95	33	M10	R1/8	M12	2.2
35	SN508	80	60	170	15	20	85	205	60	25	110	33	M10	R1/8	M12	2.6
40	SN509	85	60	170	15	20	85	205	60	25	112	31	M10	R1/8	M12	2.8
45	SN510	90	60	170	15	20	90	205	60	25	115	33	M10	R1/8	M12	3
50	SN511	100	70	210	18	23	95	255	70	28	130	33	M12	R1/8	M16	4
55	SN512	110	70	210	18	23	105	255	70	30	135	38	M12	R1/8	M16	4.5
60	SN513	120	80	230	18	23	110	275	80	30	150	43	M12	R1/8	M16	5.6
65	SN515	130	80	230	18	23	115	280	80	30	155	41	M12	R1/8	M16	6
70	SN516	140	95	260	22	27	120	315	90	32	175	43	M16	R1/8	M20	9
75	SN517	150	95	260	22	27	125	320	90	32	185	46	M16	R1/8	M20	9.3
80	SN518	160	100	290	22	27	145	345	100	35	195	62.4	M16	R1/8	M20	12
85	SN519	170	112	290	22	27	140	345	100	35	210	53	M16	R1/8	M20	14
90	SN520	180	112	320	26	32	160	380	110	40	218	70.3	M20	R1/8	M24	17
100	SN522	200	125	350	26	32	175	410	120	45	240	80	M20	R1/4	M24	20
110	SN524	215	140	350	26	32	185	410	120	45	275	86	M20	R1/4	M24	23
115	SN526	230	150	380	28	36	190	445	130	50	292	90	M24	R1/4	M24	29
125	SN528	250	150	420	33	42	205	500	150	50	305	98	M24	R1/4	M30	37
135	SN530	270	160	450	33	42	220	530	160	60	325	106	M24	R1/4	M30	42
140	SN532	290	170	470	33	42	235	550	160	60	345	114	M24	R1/4	M30	48

1) The stabilizing ring indicates the outside diameter and width dimension.
2) Dimension Y indicates the reference dimension from the shaft center to the end in the case of the shaft end shape.
Note: 1. SN524 or larger plummer blocks are provided with a lifting eye bolt.

Plummer Blocks

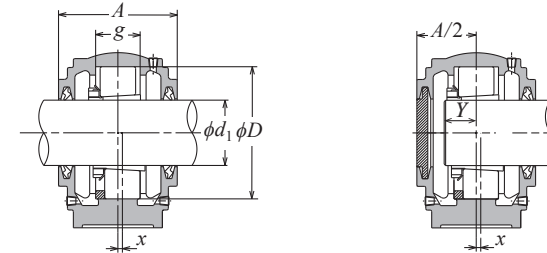

Shaft penetration type

Shaft end type

Combination of self-aligning ball bearings	Applied part						Reference dimension mm	Rubber seal number	End cover number	Shaft dia. mm	
	Bearing number	Adapter number	Stabilizing ring Number ¹⁾	Quantity	Bearing number	Adapter number					Stabilizing ring Number ¹⁾
1206SK	H206X	SR 62× 7	2	—	—	—	18	—	—	25	
2206SK	H306X	SR 62×10	1	22206EAKW33	H306X	SR 62×10	1	ZF 6	MF 6	25	
1207SK	H207X	SR 72× 8	2	—	—	—	19	—	—	30	
2207SK	H307X	SR 72×10	1	22207EAKW33	H307X	SR 72×10	1	ZF 7	MF 7	30	
1208SK	H208X	SR 80× 7.5	2	—	—	—	21	—	—	35	
2208SK	H308X	SR 80×10	1	22208EAKD1	H308X	SR 80×10	1	ZF 8	MF 8	35	
1209SK	H209X	SR 85× 6	2	—	—	—	22	—	—	40	
2209SK	H309X	SR 85× 8	1	22209EAKD1	H309X	SR 85× 8	1	ZF 9	MF 9	40	
1210SK	H210X	SR 90× 6.5	2	—	—	—	24	—	—	45	
2210SK	H310X	SR 90×10	1	22210EAKD1	H310X	SR 90×10	1	ZF10	MF10	45	
1211SK	H211X	SR100× 6	2	—	—	—	25	—	—	50	
2211SK	H311X	SR100× 8	1	22211EAKD1	H311X	SR100× 8	1	ZF11	MF11	50	
1212SK	H212X	SR110× 8	2	—	—	—	26	—	—	55	
2212SK	H312X	SR110×10	1	22212EAKD1	H312X	SR110×10	1	ZF12	MF12	55	
1213SK	H213X	SR120×10	2	—	—	—	28	—	—	60	
2213SK	H313X	SR120×12	1	22213EAKD1	H313X	SR120×12	1	ZF13	MF13	60	
1215SK	H215X	SR130× 8	2	—	—	—	30	—	—	65	
2215SK	H315X	SR130×10	1	22215EAKD1	H315X	SR130×10	1	ZF15	MF15	65	
1216SK	H216X	SR140× 8.5	2	—	—	—	32	—	—	70	
2216SK	H316X	SR140×10	1	22216EAKD1	H316X	SR140×10	1	ZF16	MF16	70	
1217SK	H217X	SR150× 9	2	—	—	—	34	—	—	75	
2217SK	H317X	SR150×10	1	22217EAKD1	H317X	SR150×10	1	ZF17	MF17	75	
1218SK	H218X	SR160×16.2	2	—	—	—	35	—	—	80	
2218SK	H318X	SR160×11.2	2	22218EAKD1	H318X	SR160×11.2	2	ZF18	MF18	80	
—	—	—	—	23218EMKD1	H2318X	SR160×10	1	46	—	—	
1219SK	H219X	SR170×10.5	2	—	—	—	37	—	—	85	
2219SK	H319X	SR170×10	1	22219EAKD1	H319X	SR170×10	1	ZF19	MF19	85	
1220SK	H220X	SR180×18.1	2	—	—	—	39	—	—	90	
2220SK	H320X	SR180×12.1	2	22220EAKD1	H320X	SR180×12.1	2	ZF20	MF20	90	
—	—	—	—	23220EMKD1	H2320X	SR180×10	1	52	—	—	
1222SK	H222X	SR200×21	2	—	—	—	42	—	—	100	
2222SK	H322X	SR200×13.5	2	22222EAKD1	H322X	SR200×13.5	2	ZF22	MF22	100	
—	—	—	—	23222EMKD1	H2322X	SR200×10	1	58	—	—	
—	—	—	—	22224EAKD1	H3124X	SR215×14	2	53	ZF24	MF24	110
—	—	—	—	23224EMKD1	H2324X	SR215×10	1	62	—	—	
—	—	—	—	22226EAKD1	H3126	SR230×13	2	57	ZF26	MF26	115
—	—	—	—	23226EMKD1	H2326	SR230×10	1	65	—	—	
—	—	—	—	22228EAKD1	H3128	SR250×15	2	60	ZF28	MF28	125
—	—	—	—	23228EMKD1	H2328	SR250×10	1	70	—	—	
—	—	—	—	22230EAKD1	H3130	SR270×16.5	2	65	ZF30	MF30	135
—	—	—	—	23230EMKD1	H2330	SR270×10	1	76	—	—	
—	—	—	—	22232EAKD1	H3132	SR290×17	2	71	ZF32	MF32	140
—	—	—	—	23232EMKD1	H2332	SR290×10	1	83	—	—	

Note: 2. Dimension x applies to plummer block numbers using one stabilizing ring and indicates the value of deviation from the bearing center to the plummer block center. The value is 1/2 of the width dimension of the stabilizing ring.
3. Adapters for bearing series 12 can also be used with series H2 and H3.

Plummer Blocks

Plummer block series SN2
(large bore type / for cylindrical bore bearings)

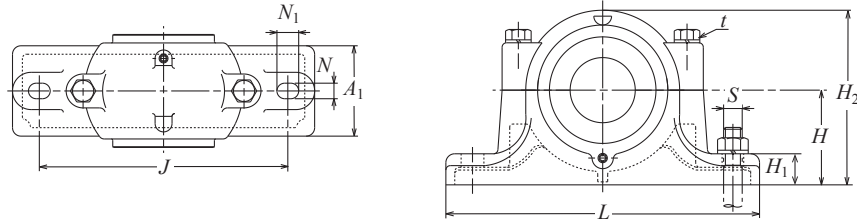

d 30-160 mm

Shaft diameter mm	Plummer block number	Dimensions											Oil filler / drain plug size	Reference dimension S	Mass kg		
		mm															
d	d ₂	D	H	J	N	N ₁	A	L	A ₁	H ₁	H ₂	g	t	S	(approx.)		
30	35	SN206	62	50	150	15	20	77	185	52	22	90	30	M 8	R1/8	M12	1.7
35	45	SN207	72	50	150	15	20	82	185	52	22	95	33	M10	R1/8	M12	2.1
40	50	SN208	80	60	170	15	20	85	205	60	25	110	33	M10	R1/8	M12	2.7
45	55	SN209	85	60	170	15	20	85	205	60	25	112	31	M10	R1/8	M12	3
50	60	SN210	90	60	170	15	20	90	205	60	25	115	33	M10	R1/8	M12	3.2
55	65	SN211	100	70	210	18	23	95	255	70	28	130	33	M12	R1/8	M16	4.3
60	70	SN212	110	70	210	18	23	105	255	70	30	135	38	M12	R1/8	M16	5.2
65	75	SN213	120	80	230	18	23	110	275	80	30	150	43	M12	R1/8	M16	5.9
70	80	SN214	125	80	230	18	23	115	275	80	30	155	44	M12	R1/8	M16	5.7
75	85	SN215	130	80	230	18	23	115	280	80	30	155	41	M12	R1/8	M16	7.2
80	90	SN216	140	95	260	22	27	120	315	90	32	175	43	M16	R1/8	M20	8.9
85	95	SN217	150	95	260	22	27	125	320	90	32	185	46	M16	R1/8	M20	9.9
90	100	SN218	160	100	290	22	27	145	345	100	35	195	62.4	M16	R1/8	M20	12
95	110	SN219	170	112	290	22	27	140	345	100	35	210	53	M16	R1/8	M20	13
100	115	SN220	180	112	320	26	32	160	380	110	40	218	70.3	M20	R1/8	M24	17
110	125	SN222	200	125	350	26	32	175	410	120	45	240	80	M20	R1/4	M24	22
120	135	SN224	215	140	350	26	32	185	410	120	45	270	86	M20	R1/4	M24	23
130	145	SN226	230	150	380	28	36	190	445	130	50	290	90	M24	R1/4	M24	28
140	155	SN228	250	150	420	33	42	205	500	150	50	305	98	M24	R1/4	M30	36
150	165	SN230	270	160	450	33	42	220	530	160	60	325	106	M24	R1/4	M30	43
160	175	SN232	290	170	470	33	42	235	550	160	60	345	114	M24	R1/4	M30	50

1) The stabilizing ring indicates the outside diameter and width dimension.
2) Dimension Y indicates the reference dimension from the shaft center to the end in the case of the shaft end shape.
Note: 1. SN224 or larger plummer blocks are provided with a lifting eye bolt.

Plummer Blocks

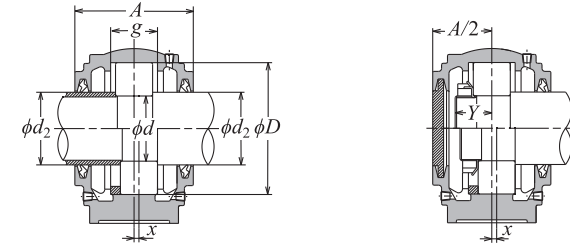

Shaft penetration type

Shaft end type

Bearing number	Applied part		Reference dimension Y ²⁾	Rubber seal number	End cover number	Shaft dia. mm
	Stabilizing ring Number ¹⁾	Quantity				
1206S	SR 62× 7	2	—	—	—	18
2206S	SR 62×10	1	22206EAW33	SR 62×10	1	20
1207S	SR 72× 8	2	—	—	—	19
2207S	SR 72×10	1	22207EAW33	SR 72×10	1	22
1208S	SR 80× 7.5	2	—	—	—	21
2208S	SR 80×10	1	22208EAD1	SR 80×10	1	23
1209S	SR 85× 6	2	—	—	—	22
2209S	SR 85× 8	1	22209EAD1	SR 85× 8	1	24
1210S	SR 90× 6.5	2	—	—	—	24
2210S	SR 90×10	1	22210EAD1	SR 90×10	1	25
1211S	SR100× 6	2	—	—	—	25
2211S	SR100× 8	1	22211EAD1	SR100× 8	1	27
1212S	SR110× 8	2	—	—	—	26
2212S	SR110×10	1	22212EAD1	SR110×10	1	29
1213S	SR120×10	2	—	—	—	28
2213S	SR120×12	1	22213EAD1	SR120×12	1	32
1214S	SR125×10	2	—	—	—	28
2214S	SR125×13	1	22214EAD1	SR125×13	1	32
1215S	SR130× 8	2	—	—	—	30
2215S	SR130×10	1	22215EAD1	SR130×10	1	33
1216S	SR140× 8.5	2	—	—	—	32
2216S	SR140×10	1	22216EAD1	SR140×10	1	36
1217S	SR150× 9	2	—	—	—	34
2217S	SR150×10	1	22217EAD1	SR150×10	1	38
1218S	SR160×16.2	2	—	—	—	35
2218S	SR160×11.2	2	22218EAD1	SR160×11.2	2	40
—	—	—	23218EMD1	SR160×10	1	46
1219S	SR170×10.5	2	—	—	—	37
2219S	SR170×10	1	22219EAD1	SR170×10	1	43
1220S	SR180×18.1	2	—	—	—	39
2220S	SR180×12.1	2	22220EAD1	SR180×12.1	2	45
—	—	—	23220EMD1	SR180×10	1	52
1222S	SR200×21	2	—	—	—	42
2222S	SR200×13.5	2	22222EAD1	SR200×13.5	2	50
—	—	—	23222EMD1	SR200×10	1	58
—	—	—	22224EAD1	SR215×14	2	53
—	—	—	23224EMD1	SR215×10	1	62
—	—	—	22226EAD1	SR230×13	2	57
—	—	—	23226EMD1	SR230×10	1	65
—	—	—	22228EAD1	SR250×15	2	60
—	—	—	23228EMD1	SR250×10	1	70
—	—	—	22230EAD1	SR270×16.5	2	65
—	—	—	23230EMD1	SR270×10	1	75
—	—	—	22232EAD1	SR290×17	2	71
—	—	—	23232EMD1	SR290×10	1	83

Note: 2. Dimension x applies to plummer block numbers using one stabilizing ring and indicates the value of deviation from the bearing center to the plummer block center. The value is 1/2 of the width dimension of the stabilizing ring.

Plummer Blocks

Plummer block series SNZ2
(stepped bore type / for cylindrical bore bearings)

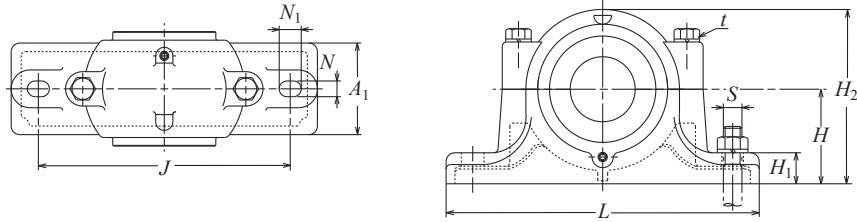

d 30–160 mm

Shaft diameter mm	Plummer block number		Dimensions											Oil filler / drain plug size	Reference dimension S	Mass kg		
			mm															
d	d ₁	d ₂	D	H	J	N	N ₁	A	L	A ₁	H ₁	H ₂	g	t	S	(approx.)		
30	25	35	SNZ206	62	50	150	15	20	77	185	52	22	90	30	M 8	R1/8	M12	1.8
35	30	45	SNZ207	72	50	150	15	20	82	185	52	22	95	33	M10	R1/8	M12	2.2
40	35	50	SNZ208	80	60	170	15	20	85	205	60	25	110	33	M10	R1/8	M12	2.9
45	40	55	SNZ209	85	60	170	15	20	85	205	60	25	112	31	M10	R1/8	M12	3.2
50	45	60	SNZ210	90	60	170	15	20	90	205	60	25	115	33	M10	R1/8	M12	3.4
55	50	65	SNZ211	100	70	210	18	23	95	255	70	28	130	33	M12	R1/8	M16	4.5
60	55	70	SNZ212	110	70	210	18	23	105	255	70	30	135	38	M12	R1/8	M16	5.4
65	60	75	SNZ213	120	80	230	18	23	110	275	80	30	150	43	M12	R1/8	M16	6.2
70	60	80	SNZ214	125	80	230	18	23	115	275	80	30	155	44	M12	R1/8	M16	6.7
75	65	85	SNZ215	130	80	230	18	23	115	280	80	30	155	41	M12	R1/8	M16	7.6
80	70	90	SNZ216	140	95	260	22	27	120	315	90	32	175	43	M16	R1/8	M20	9.4
85	75	95	SNZ217	150	95	260	22	27	125	320	90	32	185	46	M16	R1/8	M20	10
90	80	100	SNZ218	160	100	290	22	27	145	345	100	35	195	62.4	M16	R1/8	M20	13
95	85	110	SNZ219	170	112	290	22	27	140	345	100	35	210	53	M16	R1/8	M20	16
100	90	115	SNZ220	180	112	320	26	32	160	380	110	40	218	70.3	M20	R1/8	M24	18
110	100	125	SNZ222	200	125	350	26	32	175	410	120	45	240	80	M20	R1/4	M24	23
120	110	135	SNZ224	215	140	350	26	32	185	410	120	45	270	86	M20	R1/4	M24	25
130	115	145	SNZ226	230	150	380	28	36	190	445	130	50	290	90	M24	R1/4	M24	32
140	125	155	SNZ228	250	150	420	33	42	205	500	150	50	305	98	M24	R1/4	M30	41
150	135	165	SNZ230	270	160	450	33	42	220	530	160	60	325	106	M24	R1/4	M30	49
160	140	175	SNZ232	290	170	470	33	42	235	550	160	60	345	114	M24	R1/4	M30	57

1) The stabilizing ring indicates the outside diameter and width dimension.
2) Dimension Y indicates the reference dimension from the shaft center to the end in the case of the shaft end shape.
Note: 1. SNZ224 or larger plummer blocks are provided with a lifting eye bolt.

Plummer Blocks

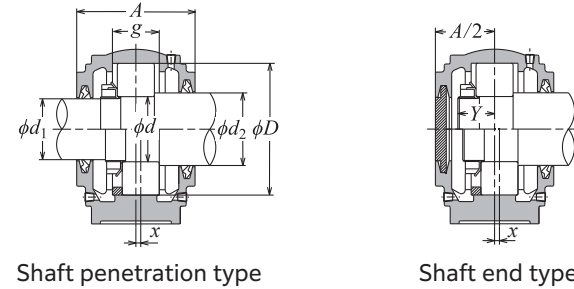

Shaft penetration type

Shaft end type

Applied part		Reference dimension mm	Rubber seal number		End cover number	Shaft dia. mm
Bearing number	Stabilizing ring Number ¹⁾ Quantity		d ₁ side	d ₂ side		
1206S SR 62× 7	2	—	—	—	—	—
2206S SR 62×10	1	22206EAW33	SR 62×10	1	AN06 AW06X	18
1207S SR 72× 8	2	—	—	—	—	—
2207S SR 72×10	1	22207EAW33	SR 72×10	1	AN07 AW07X	19
1208S SR 80× 7.5	2	—	—	—	—	—
2208S SR 80×10	1	22208EAD1	SR 80×10	1	AN08 AW08X	21
1209S SR 85× 6	2	—	—	—	—	—
2209S SR 85× 8	1	22209EAD1	SR 85× 8	1	AN09 AW09X	22
1210S SR 90× 6.5	2	—	—	—	—	—
2210S SR 90×10	1	22210EAD1	SR 90×10	1	AN10 AW10X	24
1211S SR100× 6	2	—	—	—	—	—
2211S SR100× 8	1	22211EAD1	SR100× 8	1	AN11 AW11X	25
1212S SR110× 8	2	—	—	—	—	—
2212S SR110×10	1	22212EAD1	SR110×10	1	AN12 AW12X	26
1213S SR120×10	2	—	—	—	—	—
2213S SR120×12	1	22213EAD1	SR120×12	1	AN13 AW13X	28
1214S SR125×10	2	—	—	—	—	—
2214S SR125×13	1	22214EAD1	SR125×13	1	AN14 AW14X	28
1215S SR130× 8	2	—	—	—	—	—
2215S SR130×10	1	22215EAD1	SR130×10	1	AN15 AW15	30
1216S SR140× 8.5	2	—	—	—	—	—
2216S SR140×10	1	22216EAD1	SR140×10	1	AN16 AW16X	32
1217S SR150× 9	2	—	—	—	—	—
2217S SR150×10	1	22217EAD1	SR150×10	1	AN17 AW17X	34
1218S SR160×16.2	2	—	—	—	—	—
2218S SR160×11.2	2	22218EAD1	SR160×11.2	2	AN18 AW18X	35
—	—	23218EMD1	SR160×10	1	—	40
1219S SR170×10.5	2	—	—	—	—	—
2219S SR170×10	1	22219EAD1	SR170×10	1	AN19 AW19X	37
1220S SR180×18.1	2	—	—	—	—	—
2220S SR180×12.1	2	22220EAD1	SR180×12.1	2	AN20 AW20X	39
—	—	23220EMD1	SR180×10	1	—	45
1222S SR200×21	2	—	—	—	—	—
2222S SR200×13.5	2	22222EAD1	SR200×13.5	2	AN22 AW22X	50
—	—	23222EMD1	SR200×10	1	—	58
—	—	22224EAD1	SR215×14	2	AN24 AW24X	53
—	—	23224EMD1	SR215×10	1	—	62
—	—	22226EAD1	SR230×13	2	AN26 AW26	57
—	—	23226EMD1	SR230×10	1	—	65
—	—	22228EAD1	SR250×15	2	AN28 AW28	60
—	—	23228EMD1	SR250×10	1	—	70
—	—	22230EAD1	SR270×16.5	2	AN30 AW30	65
—	—	23230EMD1	SR270×10	1	—	76
—	—	22232EAD1	SR290×17	2	AN32 AW32	71
—	—	23232EMD1	SR290×10	1	—	83

Note: 2. Dimension x applies to plummer block numbers using one stabilizing ring and indicates the value of deviation from the bearing center to the plummer block center. The value is 1/2 of the width dimension of the stabilizing ring.

Plummer Blocks



Plummer block series SN6 / S6
(standard type / for bearings with adapter)

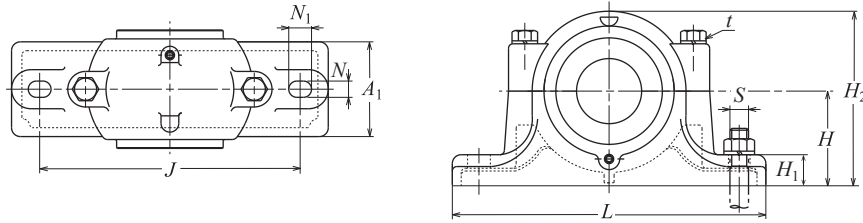

d_1 25-140 mm

Shaft dia. mm	Plummer block number	Dimensions mm										Oil filler / drain plug size	Reference dimension S	Mass kg		
		D	H	J	N	N ₁	A	L	A ₁	H ₁	H ₂				g	t
25	SN606	72	50	150	15	20	82	185	52	22	95	37	M10	R1/8	M12	2.3
30	SN607	80	60	170	15	20	90	205	60	25	110	41	M10	R1/8	M12	3
35	SN608	90	60	170	15	20	95	205	60	25	115	43	M10	R1/8	M12	3.1
40	SN609	100	70	210	18	23	105	255	70	28	130	46	M12	R1/8	M16	4.4
45	SN610	110	70	210	18	23	115	255	70	30	135	50	M12	R1/8	M16	5
50	SN611	120	80	230	18	23	120	275	80	30	150	53	M12	R1/8	M16	5.8
55	SN612	130	80	230	18	23	125	280	80	30	155	56	M12	R1/8	M16	7.7
60	SN613	140	95	260	22	27	130	315	90	32	175	58	M16	R1/8	M20	9.8
65	SN615	160	100	290	22	27	140	345	100	35	195	65	M16	R1/8	M20	12
70	SN616	170	112	290	22	27	145	345	100	35	212	68	M16	R1/8	M20	15
75	SN617	180	112	320	26	32	155	380	110	40	218	70	M20	R1/8	M24	17
80	S618	190	112	320	26	35	160	400	110	33	230	74	M20	R1/4	M24	21
85	S619	200	125	350	26	35	170	420	120	36	245	77	M20	R1/4	M24	24
90	S620	215	140	350	26	35	175	420	120	38	280	83	M20	R1/4	M24	29
100	S622	240	150	390	28	38	190	460	130	40	300	90	M24	R1/4	M24	38
110	S624	260	160	450	33	42	205	540	160	50	325	96	M24	R1/4	M30	47
115	S626	280	170	470	33	42	215	560	160	50	350	103	M24	R1/4	M30	54
125	S628	300	180	520	35	45	235	630	170	55	375	112	M30	R1/4	M30	70
135	S630	320	190	560	35	45	245	680	180	55	395	118	M30	R1/4	M30	75
140	S632	340	200	580	42	52	255	710	190	60	415	124	M30	R1/4	M36	80

Plummer Blocks

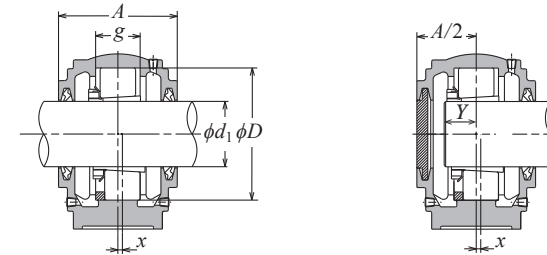

Shaft penetration type

Shaft end type

Combination of self-aligning ball bearings Bearing number	Adapter number	Stabilizing ring Number ¹⁾	Quantity	Applied part			Reference dimension mm	Rubber seal number	End cover number	Shaft dia. mm	
				Combination of spherical roller bearings Bearing number	Adapter number	Stabilizing ring Number ¹⁾					Quantity
1306SK	H306X	SR 72× 9	2	—	—	—	19	—	—	25	
2306SK	H2306X	SR 72×10	1	—	—	—	23	ZF 6	MF 6	25	
1307SK	H307X	SR 80×10	2	—	—	—	21	—	—	30	
2307SK	H2307X	SR 80×10	1	—	—	—	26	ZF 7	MF 7	30	
1308SK	H308X	SR 90×10	2	21308CK	H308X	SR 90×10	2	23	—	35	
2308SK	H2308X	SR 90×10	1	22308EAKD1	H2308X	SR 90×10	1	28	ZF 8	MF 8	35
1309SK	H309X	SR100×10.5	2	21309CK	H309X	SR100×10.5	2	25	—	40	
2309SK	H2309X	SR100×10	1	22309EAKD1	H2309X	SR100×10	1	31	ZF 9	MF 9	40
1310SK	H310X	SR110×11.5	2	21310CK	H310X	SR110×11.5	2	27	—	45	
2310SK	H2310X	SR110×10	1	22310EAKD1	H2310X	SR110×10	1	34	ZF10	MF10	45
1311SK	H311X	SR120×12	2	21311K	H311X	SR120×12	2	29	—	50	
2311SK	H2311X	SR120×10	1	22311EAKD1	H2311X	SR120×10	1	36	ZF11	MF11	50
1312SK	H312X	SR130×12.5	2	21312K	H312X	SR130×12.5	2	31	—	55	
2312SK	H2312X	SR130×10	1	22312EAKD1	H2312X	SR130×10	1	39	ZF12	MF12	55
1313SK	H313X	SR140×12.5	2	21313K	H313X	SR140×12.5	2	33	—	60	
2313SK	H2313X	SR140×10	1	22313EAKD1	H2313X	SR140×10	1	40	ZF13	MF13	60
1315SK	H315X	SR160×14	2	21315K	H315X	SR160×14	2	36	—	65	
2315SK	H2315X	SR160×10	1	22315EAKD1	H2315X	SR160×10	1	45	ZF15	MF15	65
1316SK	H316X	SR170×14.5	2	21316K	H316X	SR170×14.5	2	39	—	70	
2316SK	H2316X	SR170×10	1	22316EAKD1	H2316X	SR170×10	1	48	ZF16	MF16	70
1317SK	H317X	SR180×14.5	2	21317K	H317X	SR180×14.5	2	41	—	75	
2317SK	H2317X	SR180×10	1	22317EAKD1	H2317X	SR180×10	1	50	ZF17	MF17	75
1318SK	H318X	SR190×15.3	2	21318K	H318X	SR190×15.3	2	42	—	80	
2318SK	H2318X	SR190× 9.5	1	22318EAKD1	H2318X	SR190× 9.5	1	52	ZF18	MF18	80
1319SK	H319X	SR200×15.8	2	21319K	H319X	SR200×15.8	2	44	—	85	
2319SK	H2319X	SR200× 9.5	1	22319EAKD1	H2319X	SR200× 9.5	1	55	ZF19	MF19	85
1320SK	H320X	SR215×17.8	2	21320K	H320X	SR215×17.8	2	46	—	90	
2320SK	H2320X	SR215× 9.5	1	22320EAKD1	H2320X	SR215× 9.5	1	59	ZF20	MF20	90
1322SK	H322X	SR240×19.8	2	21322K	H322X	SR240×19.8	2	48	—	100	
2322SK	H2322X	SR240× 9.5	1	22322EAKD1	H2322X	SR240× 9.5	1	63	ZF22	MF22	100
—	—	—	—	22324EAKD1	H2324X	SR260× 9.5	1	67	ZF24	MF24	110
—	—	—	—	22326EAKD1	H2326	SR280× 9.5	1	72	ZF26	MF26	115
—	—	—	—	22328EAKD1	H2328	SR300× 9.5	1	77	ZF28	MF28	125
—	—	—	—	22330EMKD1	H2330	SR320× 9.5	1	82	ZF30	MF30	135
—	—	—	—	22332EMKD1	H2332	SR340× 9.5	1	88	ZF32	MF32	140

1) The stabilizing ring indicates the outside diameter and width dimension.
2) Dimension Y indicates the reference dimension from the shaft center to the end in the case of the shaft end shape.
Note: 1. S618 or larger plummer blocks are provided with a lifting eye bolt.

Note: 2. Dimension x applies to plummer block numbers using one stabilizing ring and indicates the value of deviation from the bearing center to the plummer block center. The value is 1/2 of the width dimension of the stabilizing ring.

Plummer Blocks

Plummer block series SN3 / S3
(large bore type / for cylindrical bore bearings)

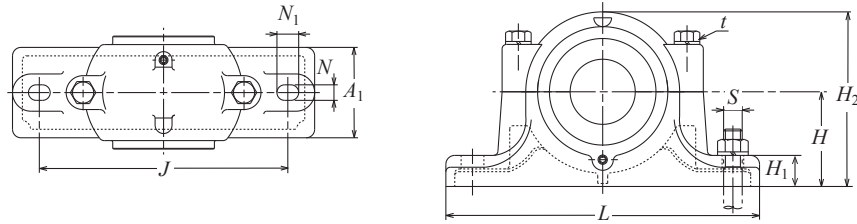

Plummer Blocks

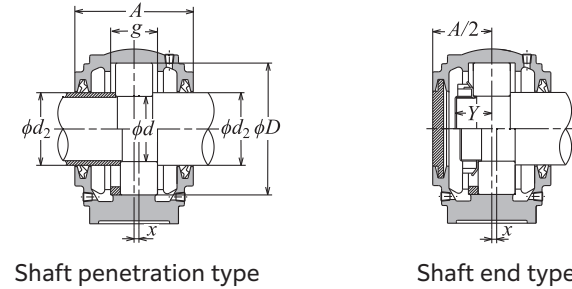

Shaft penetration type

Shaft end type

d 30-160 mm

Shaft diameter mm	Plummer block number	Dimensions											Oil filler / drain plug size	Reference dimension S	Mass kg (approx.)		
		mm															
d	d ₂	D	H	J	N	N ₁	A	L	A ₁	H ₁	H ₂	t	g	Nominal dimension	kg		
30	35	SN306	72	50	150	15	20	82	185	52	22	95	37	M10	R1/8	M12	1.8
30	40	SN306X	72	50	150	15	20	82	185	52	22	95	37	M10	R1/8	M12	1.8
35	45	SN307	80	60	170	15	20	90	205	60	25	110	41	M10	R1/8	M12	2.6
40	50	SN308	90	60	170	15	20	95	205	60	25	115	43	M10	R1/8	M12	2.9
45	55	SN309	100	70	210	18	23	105	255	70	28	130	46	M12	R1/8	M16	4.1
50	60	SN310	110	70	210	18	23	115	255	70	30	135	50	M12	R1/8	M16	4.7
55	65	SN311	120	80	230	18	23	120	275	80	30	150	53	M12	R1/8	M16	5.8
60	70	SN312	130	80	230	18	23	125	280	80	30	155	56	M12	R1/8	M16	6.5
65	75	SN313	140	95	260	22	27	130	315	90	32	175	58	M16	R1/8	M20	8.7
70	80	SN314	150	95	260	22	27	130	320	90	32	185	61	M16	R1/8	M20	10
75	85	SN315	160	100	290	22	27	140	345	100	35	195	65	M16	R1/8	M20	11
80	90	SN316	170	112	290	22	27	145	345	100	35	212	68	M16	R1/8	M20	13
85	95	SN317	180	112	320	26	32	155	380	110	40	218	70	M20	R1/8	M24	15
85	100	SN317X	180	112	320	26	32	155	380	110	40	218	70	M20	R1/8	M24	15
90	100	S318	190	112	320	26	35	160	400	110	33	230	74	M20	R1/4	M24	22
90	105	S318X	190	112	320	26	35	160	400	110	33	230	74	M20	R1/4	M24	22
95	110	S319	200	125	350	26	35	170	420	120	36	245	77	M20	R1/4	M24	26
100	115	S320	215	140	350	26	35	175	420	120	38	280	83	M20	R1/4	M24	32
110	125	S322	240	150	390	28	38	190	460	130	40	300	90	M24	R1/4	M24	42
120	135	S324	260	160	450	33	42	205	540	160	50	325	96	M24	R1/4	M30	61
130	150	S326	280	170	470	33	42	215	560	160	50	350	103	M24	R1/4	M30	68
140	160	S328	300	180	520	35	45	235	630	170	55	375	112	M30	R1/4	M30	95
150	170	S330	320	190	560	35	45	245	680	180	55	395	118	M30	R1/4	M30	110
160	180	S332	340	200	580	42	52	255	710	190	60	415	124	M30	R1/4	M36	130

Combination of self-aligning ball bearings Bearing number	Applied part		Reference dimension Y ²⁾	Rubber seal number	End cover number	Shaft dia. mm
	Combination of spherical roller bearings Bearing number	Stabilizing ring Number ¹⁾ Quantity				
1306S	SR 72× 9	2	19	ZF 8	MF 8	30
2306S	SR 72×10	1	23	ZF 9	MF 9	30
1306S	SR 72× 9	2	19	ZF 10	MF 10	35
2306S	SR 72×10	1	23	ZF 11	MF 11	40
1307S	SR 80×10	2	21	ZF 12	MF 12	45
2307S	SR 80×10	1	26	ZF 13	MF 13	50
1308S	SR 90×10	2	23	ZF 15	MF 15	55
2308S	SR 90×10	1	28	ZF 16	MF 16	60
1309S	SR100×10.5	2	25	ZF 17	MF 17	65
2309S	SR100×10	1	31	ZF 18	MF 18	70
1310S	SR110×11.5	2	27	ZF 19	MF 19	75
2310S	SR110×10	1	34	ZF 20	MF 20	80
1311S	SR120×12	2	29	ZF 21	MF 21	85
2311S	SR120×10	1	36	ZF 22	MF 22	85
1312S	SR130×12.5	2	31	ZF 23	MF 23	90
2312S	SR130×10	1	39	ZF 24	MF 24	95
1313S	SR140×12.5	2	33	ZF 25	MF 25	100
2313S	SR140×10	1	40	ZF 26	MF 26	100
1314S	SR150×13	2	34	ZF 27	MF 27	110
2314S	SR150×10	1	42	ZF 28	MF 28	110
1315S	SR160×14	2	36	ZF 29	MF 29	120
2315S	SR160×10	1	45	ZF 30	MF 30	120
1316S	SR170×14.5	2	39	ZF 31	MF 31	130
2316S	SR170×10	1	48	ZF 32	MF 32	130
1317S	SR180×14.5	2	41	ZF 33	MF 33	140
2317S	SR180×10	1	50	ZF 34	MF 34	140
1317S	SR180×14.5	2	41	ZF 35	MF 35	150
2317S	SR180×10	1	50	ZF 36	MF 36	150
1318S	SR190×15.3	2	42	ZF 37	MF 37	160
2318S	SR190× 9.5	1	52	ZF 38	MF 38	160
1318S	SR190×15.3	2	42	ZF 39	MF 39	160
2318S	SR190× 9.5	1	52	ZF 40	MF 40	160
1319S	SR200×15.8	2	44	ZF 40	MF 40	160
2319S	SR200× 9.5	1	55	ZF 40	MF 40	160
1320S	SR215×17.8	2	46	ZF 40	MF 40	160
2320S	SR215× 9.5	1	59	ZF 40	MF 40	160
1322S	SR240×19.8	2	48	ZF 40	MF 40	160
2322S	SR240× 9.5	1	63	ZF 40	MF 40	160
—	—	—	67	ZF 30	MF 30	120
—	—	—	72	ZF 34	MF 34	130
—	—	—	77	ZF 36	MF 36	140
—	—	—	82	ZF 38	MF 38	150
—	—	—	88	ZF 40	MF 40	160

1) The stabilizing ring indicates the outside diameter and width dimension.
2) Dimension Y indicates the reference dimension from the shaft center to the end in the case of the shaft end shape.
Note: 1. S318 or larger plummer blocks are provided with a lifting eye bolt.

Note: 2. Dimension x applies to plummer block numbers using one stabilizing ring and indicates the value of deviation from the bearing center to the plummer block center. The value is 1/2 of the width dimension of the stabilizing ring.

Plummer Blocks

Plummer block series SNZ3 / SZ3 (stepped bore type / for cylindrical bore bearings)

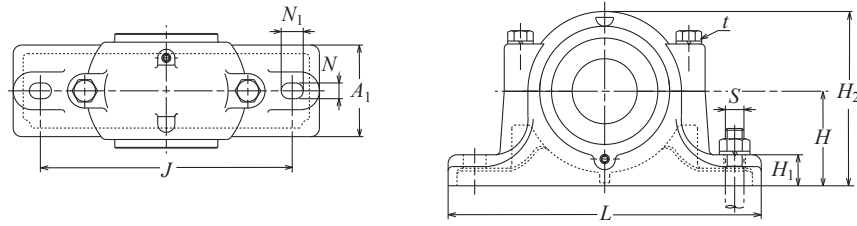

Plummer Blocks

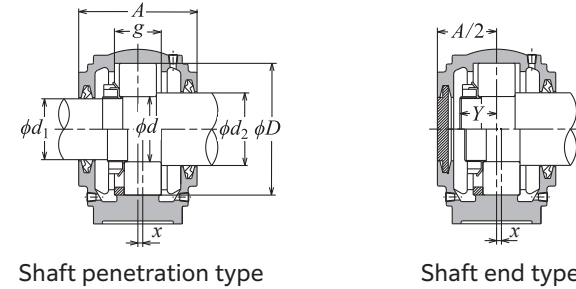

d 30-160 mm

Shaft diameter mm	Plummer block number		Dimensions mm										Oil filler / drain plug size t	Reference dimension S	Mass kg (approx.)			
			D	H	J	N	N1	A	L	A1	H1	H2				g	Nominal no.	Nominal dimension
30	25	35	SNZ306	72	50	150	15	20	82	185	52	22	95	37	M10	R1/8	M12	2.1
30	25	40	SNZ306X	72	50	150	15	20	82	185	52	22	95	37	M10	R1/8	M12	2.1
35	30	45	SNZ307	80	60	170	15	20	90	205	60	25	110	41	M10	R1/8	M12	3.1
40	35	50	SNZ308	90	60	170	15	20	95	205	60	25	115	43	M10	R1/8	M12	3.5
45	40	55	SNZ309	100	70	210	18	23	105	255	70	28	130	46	M12	R1/8	M16	4.8
50	45	60	SNZ310	110	70	210	18	23	115	255	70	30	135	50	M12	R1/8	M16	5.6
55	50	65	SNZ311	120	80	230	18	23	120	275	80	30	150	53	M12	R1/8	M16	6.6
60	55	70	SNZ312	130	80	230	18	23	125	280	80	30	155	56	M12	R1/8	M16	7.9
65	60	75	SNZ313	140	95	260	22	27	130	315	90	32	175	58	M16	R1/8	M20	11
70	60	80	SNZ314	150	95	260	22	27	130	320	90	32	185	61	M16	R1/8	M20	12
75	65	85	SNZ315	160	100	290	22	27	140	345	100	35	195	65	M16	R1/8	M20	13
80	70	90	SNZ316	170	112	290	22	27	145	345	100	35	212	68	M16	R1/8	M20	16
85	75	95	SNZ317	180	112	320	26	32	155	380	110	40	218	70	M20	R1/8	M24	18
85	75	100	SNZ317X	180	112	320	26	32	155	380	110	40	218	70	M20	R1/8	M24	18
90	80	100	SZ318	190	112	320	26	35	160	400	110	33	230	74	M20	R1/4	M24	21
90	80	105	SZ318X	190	112	320	26	35	160	400	110	33	230	74	M20	R1/4	M24	21
95	85	110	SZ319	200	125	350	26	35	170	420	120	36	245	77	M20	R1/4	M24	23
100	90	115	SZ320	215	140	350	26	35	175	420	120	38	280	83	M20	R1/4	M24	32
110	100	125	SZ322	240	150	390	28	38	190	460	130	40	300	90	M24	R1/4	M24	42
120	110	135	SZ324	260	160	450	33	42	205	540	160	50	325	96	M24	R1/4	M30	61
130	115	150	SZ326	280	170	470	33	42	215	560	160	50	350	103	M24	R1/4	M30	68
140	125	160	SZ328	300	180	520	35	45	235	630	170	55	375	112	M30	R1/4	M30	95
150	135	170	SZ330	320	190	560	35	45	245	680	180	55	395	118	M30	R1/4	M30	110
160	140	180	SZ332	340	200	580	42	52	255	710	190	60	415	124	M30	R1/4	M36	130

1) The stabilizing ring indicates the outside diameter and width dimension.
 2) Dimension Y indicates the reference dimension from the shaft center to the end in the case of the shaft end shape.
 Note: 1. SZ318 or larger plummer blocks are provided with a lifting eye bolt.

Applied part				Reference dimension	Rubber seal	End cover	Shaft
Combination of self-aligning ball bearings	Combination of spherical roller bearings	Nut	Washer	mm	number	number	dia.
Bearing number	Stabilizing ring Number ¹⁾ Quantity	Bearing number	Stabilizing ring Number ¹⁾ Quantity	Y ²⁾	d ₁ side	d ₂ side	d
1306S	SR 72× 9	2	—	19	ZF 6	ZF 8	30
2306S	SR 72×10	1	—	23	ZF 6	ZF 9	30
1306S	SR 72× 9	2	—	19	ZF 6	ZF 9	30
2306S	SR 72×10	1	—	23	ZF 6	ZF 9	30
1307S	SR 80×10	2	—	21	ZF 7	ZF10	35
2307S	SR 80×10	1	—	26	ZF 7	ZF10	35
1308S	SR 90×10	2	21308C	23	ZF 8	ZF11	40
2308S	SR 90×10	1	22308EAD1	28	ZF 8	ZF11	40
1309S	SR100×10.5	2	21309C	25	ZF 9	ZF12	45
2309S	SR100×10	1	22309EAD1	31	ZF 9	ZF12	45
1310S	SR110×11.5	2	21310C	27	ZF10	ZF13	50
2310S	SR110×10	1	22310EAD1	34	ZF10	ZF13	50
1311S	SR120×12	2	21311	29	ZF11	ZF15	55
2311S	SR120×10	1	22311EAD1	36	ZF11	ZF15	55
1312S	SR130×12.5	2	21312	31	ZF12	ZF16	60
2312S	SR130×10	1	22312EAD1	39	ZF12	ZF16	60
1313S	SR140×12.5	2	21313	33	ZF13	ZF17	65
2313S	SR140×10	1	22313EAD1	40	ZF13	ZF17	65
1314S	SR150×13	2	21314	34	ZF13	ZF18	70
2314S	SR150×10	1	22314EAD1	42	ZF13	ZF18	70
1315S	SR160×14	2	21315	36	ZF15	ZF19	75
2315S	SR160×10	1	22315EAD1	45	ZF15	ZF19	75
1316S	SR170×14.5	2	21316	39	ZF16	ZF20	80
2316S	SR170×10	1	22316EAD1	48	ZF16	ZF20	80
1317S	SR180×14.5	2	21317	41	ZF17	ZF21	85
2317S	SR180×10	1	22317EAD1	50	ZF17	ZF21	85
1317S	SR180×14.5	2	21317	41	ZF17	ZF22	85
2317S	SR180×10	1	22317EAD1	50	ZF17	ZF22	85
1318S	SR190×15.3	2	21318	42	ZF18	ZF22	90
2318S	SR190× 9.5	1	22318EAD1	52	ZF18	ZF22	90
1318S	SR190×15.3	2	21318	42	ZF18	ZF23	90
2318S	SR190× 9.5	1	22318EAD1	52	ZF18	ZF23	90
1319S	SR200×15.8	2	21319	44	ZF19	ZF24	95
2319S	SR200× 9.5	1	22319EAD1	55	ZF19	ZF24	95
1320S	SR215×17.8	2	21320	46	ZF20	ZF26	100
2320S	SR215× 9.5	1	22320EAD1	59	ZF20	ZF26	100
1322S	SR240×19.8	2	21322	48	ZF22	ZF28	110
2322S	SR240× 9.5	1	22322EAD1	63	ZF22	ZF28	110
—	—	—	22324EAD1	67	ZF24	ZF30	120
—	—	—	22326EAD1	72	ZF26	ZF34	130
—	—	—	22328EAD1	77	ZF28	ZF36	140
—	—	—	22330EMD1	82	ZF30	ZF38	150
—	—	—	22332EMD1	88	ZF32	ZF40	160

Note: 2. Dimension x applies to plummer block numbers using one stabilizing ring and indicates the value of deviation from the bearing center to the plummer block center. The value is 1/2 of the width dimension of the stabilizing ring.

● Plummer Blocks

NTN

Plummer block series SD5 / SD5G / SD6 / SD6G
(for heavy loads, double seal type / for bearings with adapters)

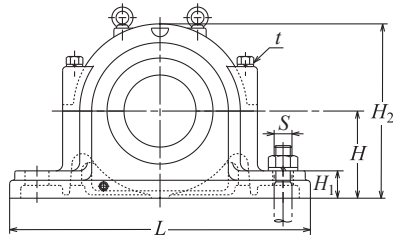
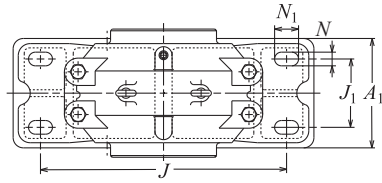

d_1 150–300 mm

Shaft dia. mm	Plummer block number		Dimensions													t Nominal no.
			mm													
d_1	Floating side	Fixed side	D	H	J	J_1	N	N_1	A	L	A_1	H_1	H_2	$g^{1)}$		
150	SD534	SD534G	310	180	510	140	32	52	270	620	230	60	360	96	M24	
160	SD536	SD536G	320	190	540	150	32	52	280	650	240	60	380	96	M24	
170	SD538	SD538G	340	200	570	160	35	55	290	700	260	65	400	102	M30	
180	SD540	SD540G	360	210	610	170	35	55	300	740	270	65	420	108	M30	
200	SD544	SD544G	400	240	680	190	40	60	330	820	300	70	475	118	M30	
220	SD548	SD548G	440	260	740	200	42	62	340	880	310	85	515	130	M36	
240	SD552	SD552G	480	280	790	210	42	62	370	940	340	85	560	140	M36	
260	SD556	SD556G	500	300	830	230	50	70	390	990	370	100	590	140	M36	
280	SD560	SD560G	540	325	890	250	50	70	410	1 060	390	100	640	150	M36	
300	SD564	SD564G	580	355	930	270	57	77	440	1 110	420	110	690	160	M42	

150	SD634	SD634G	360	210	610	170	35	55	300	740	270	65	420	130	M30
160	SD636	SD636G	380	225	640	180	40	60	320	780	290	70	450	136	M30
170	SD638	SD638G	400	240	680	190	40	60	330	820	300	70	475	142	M30
180	SD640	SD640G	420	250	710	200	42	62	350	860	320	85	500	148	M36
200	SD644	SD644G	460	280	770	210	42	62	360	920	330	85	550	155	M36
220	SD648	SD648G	500	300	830	230	50	70	390	990	370	100	590	165	M36
240	SD652	SD652G	540	325	890	250	50	70	410	1 060	390	100	640	175	M36
260	SD656	SD656G	580	355	930	270	57	77	440	1 110	420	110	690	185	M42

● Plummer Blocks

NTN

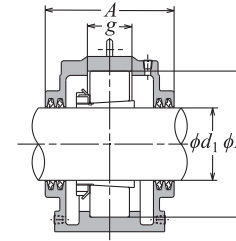

Shaft penetration type

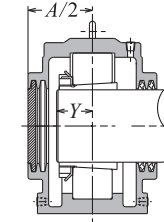

Shaft end type

Oil filler / drain plug size	Reference dimension S Nominal dimension	Mass (approx.)	Applied part Combination of spherical roller bearings Bearing number Adapter number		Reference dimension mm $Y^{2)}$	Rubber seal number	End cover number	Shaft dia. mm d_1
R3/8	M30	95	22234EMKD1	H3134	75	ZF34	MF34	150
R3/8	M30	110	22236EMKD1	H3136	76	ZF36	MF36	160
R3/8	M30	130	22238EMKD1	H3138	80	ZF38	MF38	170
R3/8	M30	150	22240EMKD1	H3140	84	ZF40	MF40	180
R3/8	M36	210	22244EMKD1	H3144	90	ZF44	MF44	200
R3/8	M36	240	22248EMKD1	H3148	98	ZF48	MF48	220
R3/8	M36	320	22252EMKD1	H3152	105	ZF52	MF52	240
R3/8	M42	370	22256EMKD1	H3156	107	ZF56	MF56	260
R3/8	M42	460	22260EMKD1	H3160	114	ZF60	MF60	280
R3/8	M48	560	22264EMKD1	H3164	122	ZF64	MF64	300
R3/8	M30	150	22334EMKD1	H2334	92	ZF34	MF34	150
R3/8	M36	180	22336EMKD1	H2336	96	ZF36	MF36	160
R3/8	M36	210	22338EMKD1	H2338	100	ZF38	MF38	170
R3/8	M36	240	22340EMKD1	H2340	104	ZF40	MF40	180
R3/8	M36	300	22344EMKD1	H2344	109	ZF44	MF44	200
R3/8	M42	370	22348EMKD1	H2348	116	ZF48	MF48	220
R3/8	M42	460	22352EMKD1	H2352	123	ZF52	MF52	240
R3/8	M48	560	22356EMKD1	H2356	130	ZF56	MF56	260

1) Dimension g indicates the bearing width dimension of the floating side. The fixed side (code G) is larger than the bearing width dimension by 0.5 mm.

2) Dimension Y indicates the reference dimension from the shaft center to the end in the case of the shaft end shape.

Plummer Blocks



Plummer block series SD2 / SD2G / SD3 / SD3G
(for heavy loads, stepped bore type / for cylindrical bore bearings)

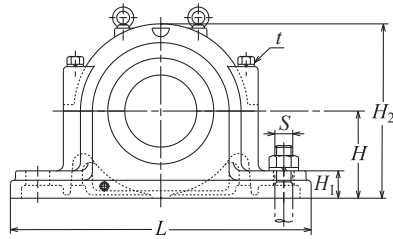
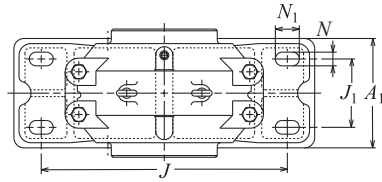

d 170–320 mm

Shaft diameter		Plummer block number		Dimensions													t Nominal no.
mm		Floating side	Fixed side	mm													
d	d ₁	d ₂		D	H	J	J ₁	N	N ₁	A	L	A ₁	H ₁	H ₂	g ¹⁾		
170	160	190	SD234 SD234G	310	180	510	140	32	52	270	620	230	60	360	96	M24	
180	170	200	SD236 SD236G	320	190	540	150	32	52	280	650	240	60	380	96	M24	
190	180	210	SD238 SD238G	340	200	570	160	35	55	290	700	260	65	400	102	M30	
200	190	220	SD240 SD240G	360	210	610	170	35	55	300	740	270	65	420	108	M30	
220	210	240	SD244 SD244G	400	240	680	190	40	60	330	820	300	70	475	118	M30	
240	230	260	SD248 SD248G	440	260	740	200	42	62	340	880	310	85	515	130	M36	
260	250	280	SD252 SD252G	480	280	790	210	42	62	370	940	340	85	560	140	M36	
280	260	300	SD256 SD256G	500	300	830	230	50	70	390	990	370	100	590	140	M36	
300	280	320	SD260 SD260G	540	325	890	250	50	70	410	1 060	390	100	640	150	M36	
320	300	340	SD264 SD264G	580	355	930	270	57	77	440	1 110	420	110	690	160	M42	

170	160	190	SD334 SD334G	360	210	610	170	35	55	300	740	270	65	420	130	M30
180	170	200	SD336 SD336G	380	225	640	180	40	60	320	780	290	70	450	136	M30
190	180	210	SD338 SD338G	400	240	680	190	40	60	330	820	300	70	475	142	M30
200	190	220	SD340 SD340G	420	250	710	200	42	62	350	860	320	85	500	148	M36
220	210	240	SD344 SD344G	460	280	770	210	42	62	360	920	330	85	550	155	M36
240	230	260	SD348 SD348G	500	300	830	230	50	70	390	990	370	100	590	165	M36
260	250	280	SD352 SD352G	540	325	890	250	50	70	410	1 060	390	100	640	175	M36
280	260	300	SD356 SD356G	580	355	930	270	57	77	440	1 110	420	110	690	185	M42

Plummer Blocks

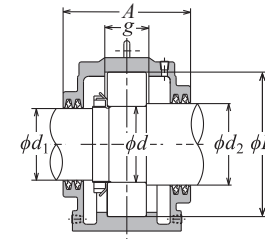

Shaft penetration type

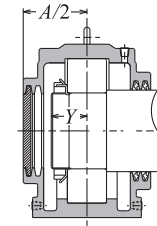

Shaft end type

Oil filler / drain plug size	Reference dimension S	Mass kg	Applied part			Reference dimension Y ²⁾	Rubber seal number		End cover number	Shaft dia. mm
			Bearing number	Adapter number	Washer / lock plate number		d ₁ side	d ₂ side		
R3/8	M30	95	22234EMD1	AN34	AW34	75	ZF36	ZF42	MF36	170
R3/8	M30	110	22236EMD1	AN36	AW36	76	ZF38	ZF44	MF38	180
R3/8	M30	130	22238EMD1	AN38	AW38	80	ZF40	ZF46	MF40	190
R3/8	M30	150	22240EMD1	AN40	AW40	84	ZF42	ZF48	MF42	200
R3/8	M36	210	22244EMD1	AN44	AL44	90	ZF46	ZF52	MF46	220
R3/8	M36	240	22248EMD1	AN48	AL44	98	GS50S	ZF56	MF50	240
R3/8	M36	320	22252EMD1	AN52	AL52	105	ZF54	ZF60	MF54	260
R3/8	M42	370	22256EMD1	AN56	AL52	107	ZF56	ZF64	MF56	280
R3/8	M42	460	22260EMD1	AN60	AL60	114	ZF60	ZF68	MF60	300
R3/8	M48	560	22264EMD1	AN64	AL64	122	ZF64	GS72	MF64	320
R3/8	M30	150	22334EMD1	AN34	AW34	92	ZF36	ZF42	MF36	170
R3/8	M36	180	22336EMD1	AN36	AW36	96	ZF38	ZF44	MF38	180
R3/8	M36	210	22338EMD1	AN38	AW38	100	ZF40	ZF46	MF40	190
R3/8	M36	240	22340EMD1	AN40	AW40	104	ZF42	ZF48	MF42	200
R3/8	M36	300	22344EMD1	AN44	AL44	109	ZF46	ZF52	MF46	220
R3/8	M42	370	22348EMD1	AN48	AL44	116	GS50S	ZF56	MF50	240
R3/8	M42	460	22352EMD1	AN52	AL52	123	ZF54	ZF60	MF54	260
R3/8	M48	560	22356EMD1	AN56	AL52	130	ZF56	ZF64	MF56	280

1) Dimension g indicates the bearing width dimension of the floating side. The fixed side (code G) is larger than the bearing width dimension by 0.5 mm.

2) Dimension Y indicates the reference dimension from the shaft center to the end in the case of the shaft end shape.

Plummer Blocks

NTN

Plummer block series SN30 / SN31
(standard type / for bearings with adapter)

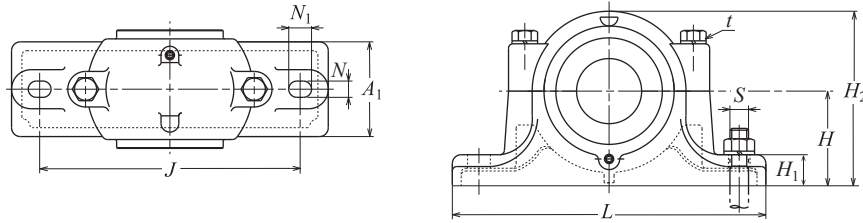

d_1 100–170 mm

Shaft dia. mm	Plummer block number	Dimensions mm											Oil filler / drain plug size	Reference dimension S Nominal dimension	Mass kg (approx.)	
		D	H	J	N	N ₁	A	L	A ₁	H ₁	H ₂	g				
110	SN3024	180	112	320	26	32	150	380	110	40	217	56	M20	R1/4	M24	17
115	SN3026	200	125	350	26	32	160	410	120	45	240	62	M20	R1/4	M24	20
125	SN3028	210	140	350	26	32	170	410	120	45	260	63	M20	R1/4	M24	25
135	SN3030	225	150	380	28	36	175	445	130	50	283	66	M24	R1/4	M24	30
140	SN3032	240	150	390	28	36	190	460	130	50	290	70	M24	R1/4	M24	33
150	SN3034	260	160	450	33	42	200	530	160	60	310	77	M24	R1/4	M30	46
160	SN3036	280	170	470	33	42	210	550	160	60	330	84	M24	R1/4	M30	52
170	SN3038	290	170	470	33	42	210	550	160	60	335	85	M24	R1/4	M30	52
100	SN3122	180	112	320	26	32	155	380	110	40	217	66	M20	R1/4	M24	18
110	SN3124	200	125	350	26	32	165	410	120	45	240	72	M20	R1/4	M24	21
115	SN3126	210	140	350	26	32	170	410	120	45	260	74	M20	R1/4	M24	26
125	SN3128	225	150	380	28	36	180	445	130	50	283	78	M24	R1/4	M24	32
135	SN3130	250	150	420	33	42	200	500	150	50	295	90	M24	R1/4	M30	40
140	SN3132	270	160	450	33	42	215	530	160	60	315	96	M24	R1/4	M30	45
150	SN3134	280	170	470	33	42	220	550	160	60	330	98	M24	R1/4	M30	51
160	SN3136	300	180	520	33	42	230	610	170	70	355	106	M30	R1/4	M30	63
170	SN3138	320	190	560	33	42	240	650	180	70	375	114	M30	R1/4	M30	76

Plummer Blocks

NTN

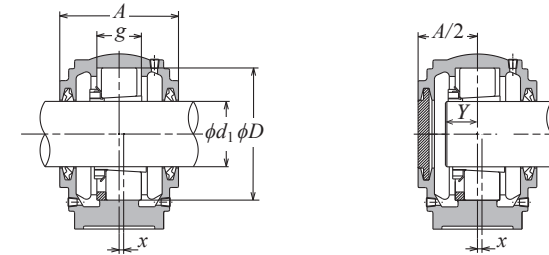

Shaft penetration type

Shaft end type

Bearing number	Applied part		Stabilizing ring Quantity	Reference dimension mm Y ²⁾	Rubber seal number	End cover number	Shaft dia. mm d_1
	Adapter Plummer block number	Stabilizing ring Plummer block number ¹⁾					
23024EAKD1	H3024X	SR180×10	1	47	ZF24	MF24	110
23026EAKD1	H3026	SR200×10	1	51	ZF26	MF26	115
23028EAKD1	H3028	SR210×10	1	53	ZF28	MF28	125
23030EAKD1	H3030	SR225×10	1	56	ZF30	MF30	135
23032EAKD1	H3032	SR240×10	1	61	ZF32	MF32	140
23034EAKD1	H3034	SR260×10	1	66	ZF34	MF34	150
23036EAKD1	H3036	SR280×10	1	70	ZF36	MF36	160
23038EAKD1	H3038	SR290×10	1	72	ZF38	MF38	170
23122EAKD1	H3122X	SR180×10	1	51	ZF22	MF22	100
23124EAKD1	H3124X	SR200×10	1	55	ZF24	MF24	110
23126EAKD1	H3126	SR210×10	1	57	ZF26	MF26	115
23128EAKD1	H3128	SR225×10	1	60	ZF28	MF28	125
23130EAKD1	H3130	SR250×10	1	68	ZF30	MF30	135
23132EAKD1	H3132	SR270×10	1	74	ZF32	MF32	140
23134EAKD1	H3134	SR280×10	1	76	ZF34	MF34	150
23136EAKD1	H3136	SR300×10	1	81	ZF36	MF36	160
23138EMKD1	H3138	SR320×10	1	86	ZF38	MF38	170

1) The stabilizing ring indicates the outside diameter and width dimension.
2) Dimension Y indicates the reference dimension from the shaft center to the end in the case of the shaft end shape.
Note: 1. SN3028 or larger and SN3126 or larger plummer blocks are provided with a lifting eye bolt.

Note: 2. Dimension x applies to plummer block numbers using one stabilizing ring and indicates the value of deviation from the bearing center to the plummer block center. The value is 1/2 of the width dimension of the stabilizing ring.

● Plummer Blocks

NTN

Plummer block series SD30 / SD30G
(for heavy loads, double seal type / for bearings with adapters)

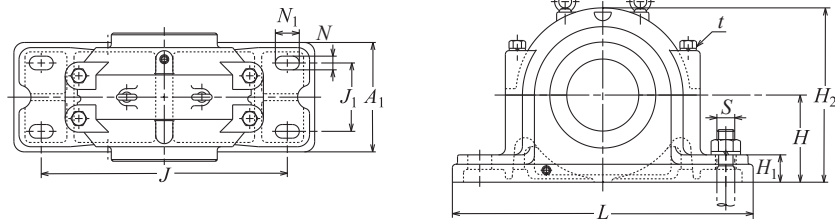

d_1 150–400 mm

Shaft dia. mm	Plummer block number ¹⁾		Dimensions													t Nominal no.
	Floating side	Fixed side	mm													
d_1			D	H	J	J_1	N	N_1	A	L	A_1	H_1	H_2	$g^{2)}$		
150	SD3034	SD3034G	260	160	450	110	32	42	230	540	200	50	320	77	M24	
160	SD3036	SD3036G	280	170	470	120	32	42	250	560	220	50	340	84	M24	
170	SD3038	SD3038G	290	170	470	120	32	42	250	560	220	50	345	85	M24	
180	SD3040	SD3040G	310	180	510	140	32	52	270	620	250	60	360	92	M24	
200	SD3044	SD3044G	340	200	570	160	35	55	290	700	280	65	400	100	M30	
220	SD3048	SD3048G	360	210	610	170	35	55	300	740	290	65	420	102	M30	
240	SD3052	SD3052G	400	240	680	190	40	60	340	820	320	70	475	114	M30	
260	SD3056	SD3056G	420	250	710	200	42	62	350	860	340	85	500	116	M36	
280	SD3060	SD3060G	460	280	770	210	42	62	360	920	350	85	550	128	M36	
300	SD3064	SD3064G	480	280	790	210	42	62	380	940	360	85	560	131	M36	
380	SD3080	SD3080G	600	365	960	270	57	77	430	1 140	420	120	710	158	M42	
400	SD3084	SD3084G	620	375	980	270	57	77	430	1 160	420	120	735	160	M42	

● Plummer Blocks

NTN

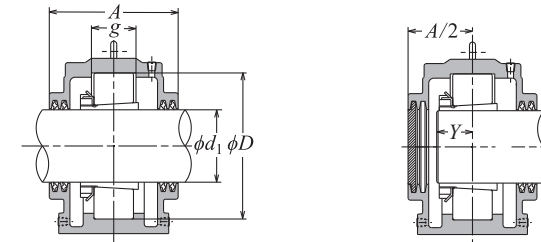

Shaft penetration type

Shaft end type

Oil filler / drain plug size	Reference dimension S Nominal dimension	Mass kg	Applied part Combination of spherical roller bearings Bearing number Adapter number		Reference dimension mm $Y^{3)}$	Rubber seal number	End cover number	Shaft dia. mm d_1
R3/8	M30	70	23034EAKD1	H3034	66	ZF34	MF34	150
R3/8	M30	80	23036EAKD1	H3036	70	ZF36	MF36	160
R3/8	M30	85	23038EAKD1	H3038	72	ZF38	MF38	170
R3/8	M30	100	23040EMKD1	H3040	76	ZF40	MF40	180
R3/8	M30	130	23044EMKD1	H3044	79	ZF44	MF44	200
R3/8	M30	150	23048EMKD1	H3048	84	ZF48	MF48	220
R3/8	M36	210	23052EMKD1	H3052	90	ZF52	MF52	240
R3/8	M36	240	23056EMKD1	H3056	95	ZF56	MF56	260
R3/8	M36	300	23060EMKD1	H3060	105	ZF60	MF60	280
R3/8	M36	320	23064EMKD1	H3064	108	ZF64	MF64	300
R3/8	M48	620	23080BK	H3080	131	GS80	MF80	380
R3/8	M48	690	23084BK	H3084	132	GS84	MF84	400

1) SD3068, SD3072, and SD3076 have the same dimensions as SD3368, SD3372, and SD3376. Therefore, when these models are necessary, select "SD3368, SD3372, and SD3376."

2) Dimension g indicates the bearing width dimension of the floating side. The fixed side (code G) is larger than the bearing width dimension by 0.5 mm.

3) Dimension Y indicates the reference dimension from the shaft center to the end in the case of the shaft end shape.

● Plummer Blocks

NTN

Plummer block series SD31 / SD31G
(for heavy loads, double seal type / for bearings with adapters)

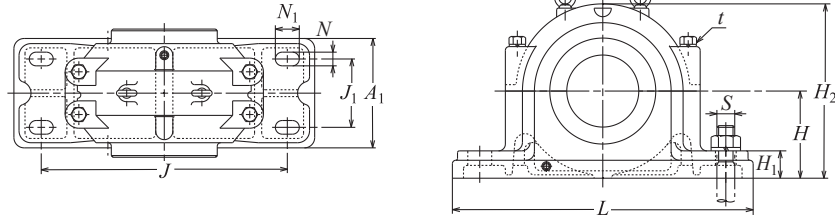

d_1 150–400 mm

Shaft dia. mm d_1	Plummer block number ¹⁾		Dimensions													t Nominal no.
	Floating side	Fixed side	mm													
			D	H	J	J_1	N	N_1	A	L	A_1	H_1	H_2	$g^{2)}$		
150	SD3134	SD3134G	280	170	470	120	35	42	250	560	220	50	340	98	M24	
160	SD3136	SD3136G	300	180	520	140	35	52	270	630	250	55	365	106	M30	
170	SD3138	SD3138G	320	190	560	140	35	55	310	680	270	55	385	114	M30	
180	SD3140	SD3140G	340	200	570	160	35	55	310	700	280	65	400	122	M30	
200	SD3144	SD3144G	370	225	640	180	40	60	320	780	310	70	450	130	M30	
220	SD3148	SD3148G	400	240	680	190	40	60	330	820	320	70	475	138	M30	
240	SD3152	SD3152G	440	260	740	200	42	62	360	880	350	85	515	154	M36	
260	SD3156	SD3156G	460	280	770	210	42	62	360	920	350	85	550	156	M36	
280	SD3160	SD3160G	500	300	830	230	50	70	390	990	380	100	590	170	M36	
300	SD3164	SD3164G	540	325	890	250	50	70	430	1 060	400	100	640	186	M36	
340	SD3172	SD3172G	600	365	960	310	57	77	470	1 140	460	120	710	202	M42	
360	SD3176	SD3176G	620	375	980	320	57	77	500	1 160	490	120	735	204	M42	
380	SD3180	SD3180G	650	390	1 040	340	57	77	520	1 220	510	125	770	210	M42	
400	SD3184	SD3184G	700	420	1 070	380	57	77	560	1 250	550	135	820	234	M42	

1) SD3168 has the same dimensions as SD3468. Therefore, when this model is necessary, select "SD3468."

2) Dimension g indicates the bearing width dimension of the floating side. The fixed side (code G) is larger than the bearing width dimension by 0.5 mm.

3) Dimension Y indicates the reference dimension from the shaft center to the end in the case of the shaft end shape.

● Plummer Blocks

NTN

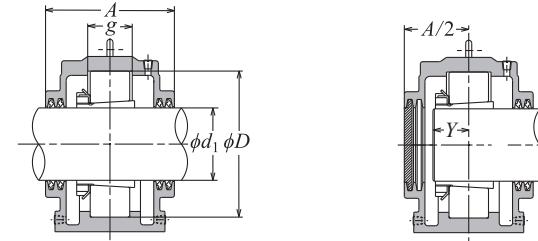

Shaft penetration type

Shaft end type

Oil filler / drain plug size	Reference dimension S Nominal dimension	Mass kg (approx.)	Applied part Combination of spherical roller bearings Bearing number Adapter number		Reference dimension mm $Y^{3)}$	Rubber seal number	End cover number	Shaft dia. mm d_1
R3/8	M30	75	23134EAKD1	H3134	76	ZF34	MF34	150
R3/8	M30	94	23136EAKD1	H3136	81	ZF36	MF36	160
R3/8	M30	110	23138EMKD1	H3138	86	ZF38	MF38	170
R3/8	M30	130	23140EMKD1	H3140	91	ZF40	MF40	180
R3/8	M36	180	23144EMKD1	H3144	96	ZF44	MF44	200
R3/8	M36	210	23148EMKD1	H3148	102	ZF48	MF48	220
R3/8	M36	240	23152EMKD1	H3152	112	ZF52	MF52	240
R3/8	M36	310	23156EMKD1	H3156	115	ZF56	MF56	260
R3/8	M42	400	23160EMKD1	H3160	124	ZF60	MF60	280
R3/8	M42	480	23164EMKD1	H3164	135	ZF64	MF64	300
R3/8	M48	630	23172BK	H3172	159	GS72	MF72	340
R3/8	M48	850	23176BK	H3176	162	GS76	MF76	360
R3/8	M48	960	23180BK	H3180	167	GS80	MF80	380
R3/8	M48	1 080	23184BK	H3184	187	GS84	MF84	400

Plummer Blocks



Plummer block series SV5
(unit type, standard type / for bearings with adapter assembly)

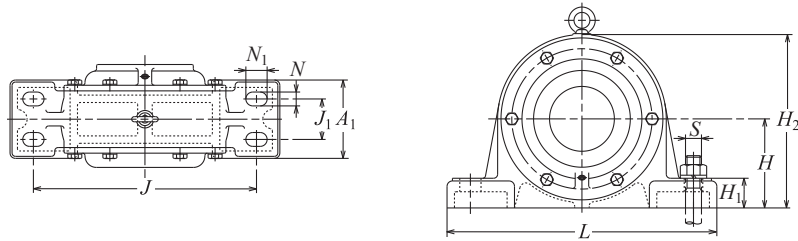

d_1 140–300 mm

Shaft dia. mm	Plummer block number	Dimensions mm											Oil filler / drain plug size	Reference dimension S		Mass kg		
		D	H	J	J ₁	N	N ₁	A	L	A ₁	A ₃	H ₁		H ₂	g		Normal dimension	Quantity (approx.)
140	SV532	290	190	470	92	29	50	250	560	170	112	60	375	113	R1/4	M24	4	76
150	SV534	310	200	560	92	29	50	258	660	180	116	65	405	122	R1/4	M24	4	89
160	SV536	320	200	560	92	29	50	258	660	180	116	65	405	122	R1/4	M24	4	100
170	SV538	340	212	580	104	33	54	300	680	190	137	65	425	130	R1/4	M27	4	110
180	SV540	360	224	610	130	33	54	300	740	224	136	85	450	138	R1/4	M27	4	130
200	SV544	400	250	680	148	36	60	330	820	250	151	95	500	154	R1/4	M30	4	196
220	SV548	440	280	740	166	40	66	340	880	280	156	100	560	170	R1/4	M33	4	260
240	SV552	480	300	790	180	43	72	370	940	300	173	105	600	184	R1/4	M36	4	318
260	SV556	500	315	830	190	43	72	390	990	315	185	110	630	186	R1/4	M36	4	336
280	SV560	540	335	890	200	46	78	410	1060	335	196	115	670	202	R1/4	M39	4	433
300	SV564	580	355	930	215	49	84	440	1110	355	211	120	710	218	R1/4	M42	4	507

1) The stabilizing ring indicates the outside diameter and width dimension.
2) Dimension Y indicates the reference dimension from the shaft center to the end in the case of the shaft end shape.
Note: 1. SV520 or larger plummer blocks are provided with a lifting eye bolt.

Plummer Blocks

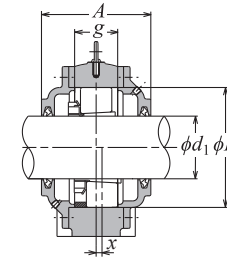

Shaft penetration type

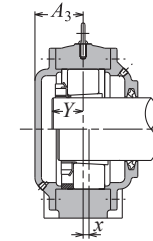

Shaft end type

Applied part						Reference dimension mm	Rubber seal number	Shaft dia. mm		
Combination of self-aligning ball bearings		Combination of spherical roller bearings								
Bearing number	Adapter number	Stabilizing ring Number ¹⁾	Quantity	Bearing number	Adapter number	Stabilizing ring Number ¹⁾	Quantity	Y ²⁾	d ₁	
—	—	—	—	22232EAKD1	H3132	SR290×16.5	2	71	ZF32	140
—	—	—	—	23232EMKD1	H2332	SR290× 9	1	83		
—	—	—	—	22234EMKD1	H3134	SR310×18	2	75	ZF34	150
—	—	—	—	23234EMKD1	H2334	SR310×12	1	87		
—	—	—	—	22236EMKD1	H3136	SR320×18	2	76	ZF36	160
—	—	—	—	23236EMKD1	H2336	SR320×10	1	89		
—	—	—	—	22238EMKD1	H3138	SR340×19	2	80	ZF38	170
—	—	—	—	23238EMKD1	H2338	SR340×10	1	94		
—	—	—	—	22240EMKD1	H3140	SR360×20	2	84	ZF40	180
—	—	—	—	23240EMKD1	H2340	SR360×10	1	99		
—	—	—	—	22244EMKD1	H3144	SR400×23	2	90	ZF44	200
—	—	—	—	23244EMKD1	H2344	SR400×10	1	108		
—	—	—	—	22248EMKD1	H3148	SR440×25	2	98	ZF48	220
—	—	—	—	23248EMKD1	H2348	SR440×10	1	118		
—	—	—	—	22252EMKD1	H3152	SR480×27	2	105	ZF52	240
—	—	—	—	23252EMKD1	H2352	SR480×10	1	127		
—	—	—	—	22256EMKD1	H3156	SR500×28	2	107	ZF56	260
—	—	—	—	23256EMKD1	H2356	SR500×10	1	130		
—	—	—	—	22260EMKD1	H3160	SR540×31	2	114	ZF60	280
—	—	—	—	23260EMKD1	H2360	SR540×10	1	160		
—	—	—	—	22264EMKD1	H3164	SR580×34	2	122	ZF64	300
—	—	—	—	23264EMKD1	H2364	SR580×10	1	151		

Note: 2. Dimension x applies to plummer block numbers using one stabilizing ring and indicates the value of deviation from the bearing center to the plummer block center. The value is 1/2 of the width dimension of the stabilizing ring.
3. Adapters for bearing series 12 can also be used with series H2 and H3.

Plummer Blocks



Plummer block series SV2
(unit type, stepped bore type / for cylindrical bore bearings)

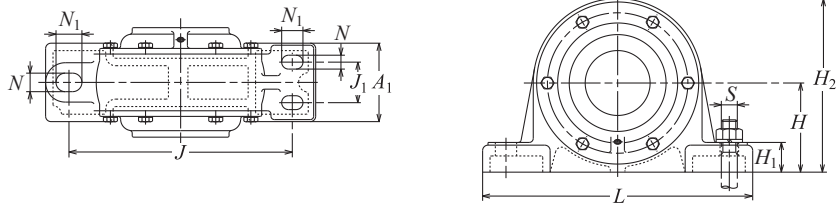

Plummer Blocks

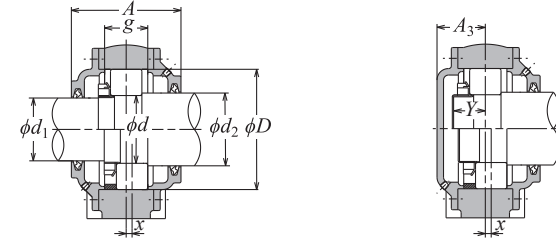

Shaft penetration type

Shaft end type

d 25-140 mm

Shaft diameter mm	Plummer block number		Dimensions mm													Oil filler / drain plug size	Reference dimension S	Mass kg		
			mm																	
			d	d ₁	d ₂	D	H	J	J ₁	N	N ₁	A	L	A ₁	A ₃				H ₁	H ₂
25	20	30	SV205	52	45	130	—	16	20	73	165	46	31	22	85	27	R1/8	M14	2	2.0
30	25	35	SV206	62	50	150	—	16	20	80	185	52	34	22	95	30	R1/8	M14	2	2.6
35	30	45	SV207	72	56	150	—	16	20	85	185	52	37.5	22	106	33	R1/8	M14	2	3.1
40	35	50	SV208	80	60	170	—	16	20	95	205	60	40.5	25	118	37	R1/8	M14	2	4.3
45	40	55	SV209	85	63	170	—	16	23	98	205	60	42.5	25	125	39	R1/8	M14	2	4.3
50	45	60	SV210	90	67	170	—	16	23	100	205	60	42.5	25	128	39	R1/8	M14	2	4.6
55	50	65	SV211	100	71	210	—	16	23	106	255	70	47	28	140	42	R1/8	M14	2	5.5
60	55	70	SV212	110	80	210	—	21	25	112	255	70	47	30	155	46	R1/8	M18	2	6.5
65	60	75	SV213	120	85	230	—	21	25	118	275	80	50	30	165	49	R1/8	M18	2	9.5
70	60	80	SV214	125	90	230	—	21	25	118	280	80	50	30	175	50	R1/8	M18	2	10
75	65	85	SV215	130	90	230	—	21	25	118	280	80	50	30	175	50	R1/8	M18	2	10
80	70	90	SV216	140	100	260	—	25	30	136	315	90	58	32	195	56	R1/8	M22	2	14
85	75	95	SV217	150	100	260	—	25	30	140	315	90	60	32	195	56	R1/8	M22	2	15
90	80	100	SV218	160	112	290	—	25	30	150	345	100	65	35	224	62	R1/8	M22	2	20
95	85	110	SV219	170	112	290	—	25	30	165	345	100	72.5	35	224	62	R1/8	M22	2	20
100	90	115	SV220	180	125	320	56	23	32	170	380	110	75	40	243	70	R1/8	M20	4	26
110	100	125	SV222	200	132	350	60	23	32	190	410	120	82	45	265	82	R1/4	M20	4	30
120	110	135	SV224	215	140	350	60	23	32	190	410	120	82	45	280	82	R1/4	M20	4	36
130	115	145	SV226	230	150	380	65	23	32	200	450	130	87	50	300	86	R1/4	M20	4	44
140	125	155	SV228	250	160	420	80	23	32	218	500	150	96	50	315	94	R1/4	M20	4	52

Combination of self-aligning ball bearings Bearing number	Applied part		Nut number	Washer number	Reference dimension mm Y ²⁾	Rubber seal number	Shaft dia. mm
	Combination of spherical roller bearings						
	Bearing number	Stabilizing ring Number ¹⁾ Quantity					
1205S	SR 52× 6	2	—	—	17	—	—
2205S	SR 52× 9	1	22205EAW33	SR 52× 9	1	AN05 AW05X	25
1206S	SR 62× 7	2	—	—	18	—	—
2206S	SR 62×10	1	22206EAW33	SR 62×10	1	AN06 AW06X	30
1207S	SR 72× 8	2	—	—	19	—	—
2207S	SR 72×10	1	22207EAW33	SR 72×10	1	AN07 AW07X	35
1208S	SR 80× 9.5	2	—	—	21	—	—
2208S	SR 80× 7	2	22208EAD1	SR 80× 7	2	AN08 AW08X	40
1209S	SR 85×10	2	—	—	22	—	—
2209S	SR 85× 8	2	22209EAD1	SR 85× 8	2	AN09 AW09X	45
1210S	SR 90× 9.5	2	—	—	24	—	—
2210S	SR 90× 8	2	22210EAD1	SR 90× 8	2	AN10 AW10X	50
1211S	SR100×10.5	2	—	—	25	—	—
2211S	SR100× 8.5	2	22211EAD1	SR100× 8.5	2	AN11 AW11X	55
1212S	SR110×12	2	—	—	26	—	—
2212S	SR110× 9	2	22212EAD1	SR110× 9	2	AN12 AW12X	60
1213S	SR120×13	2	—	—	28	—	—
2213S	SR120× 9	2	22213EAD1	SR120× 9	2	AN13 AW13X	65
1214S	SR125×13	2	—	—	28	—	—
2214S	SR125× 9.5	2	22214EAD1	SR125× 9.5	2	AN14 AW14X	70
1215S	SR130×12.5	2	—	—	30	—	—
2215S	SR130× 9.5	2	22215EAD1	SR130× 9.5	2	AN15 AW15X	75
1216S	SR140×15	2	—	—	32	—	—
2216S	SR140×11.5	2	22216EAD1	SR140×11.5	2	AN16 AW16X	80
1217S	SR150×14	2	—	—	34	—	—
2217S	SR150×10	2	22217EAD1	SR150×10	2	AN17 AW17X	85
1218S	SR160×15	2	—	—	35	—	—
2218S	SR160×11	2	22218EAD1	SR160×11	2	AN18 AW18X	90
—	—	—	23218EMD1	SR160× 9.6	1	—	—
1219S	SR170×15	2	—	—	37	—	—
2219S	SR170× 9.5	2	22219EAD1	SR170× 9.5	2	AN19 AW19X	95
1220S	SR180×18	2	—	—	39	—	—
2220S	SR180×12	2	22220EAD1	SR180×12	2	AN20 AW20X	100
—	—	—	23220EMD1	SR180× 9.7	1	—	—
1222S	SR200×22	2	—	—	42	—	—
2222S	SR200×14.5	2	22222EAD1	SR200×14.5	2	AN22 AW22X	110
—	—	—	23222EMD1	SR200×12.2	1	—	—
—	—	—	22224EAD1	SR215×12	2	—	—
—	—	—	23224EMD1	SR215× 6	1	AN24 AW24X	120
—	—	—	22226EAD1	SR230×11	2	—	—
—	—	—	23226EMD1	SR230× 6	1	AN26 AW26	130
—	—	—	22228EAD1	SR250×13	2	—	—
—	—	—	23228EMD1	SR250× 6	1	AN28 AW28	140

1) The stabilizing ring indicates the outside diameter and width dimension.
2) Dimension Y indicates the reference dimension from the shaft center to the end in the case of the shaft end shape.
Note: 1. SV220 or larger plummer blocks are provided with a lifting eye bolt.

Note: 2. Dimension x applies to plummer block numbers using one stabilizing ring and indicates the value of deviation from the bearing center to the plummer block center. The value is 1/2 of the width dimension of the stabilizing ring.

● Plummer Blocks

NTN

Plummer block series SV2
(unit type, stepped bore type / for cylindrical bore bearings)

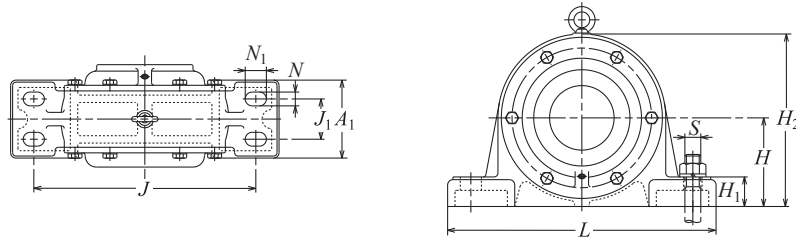

d 150–320 mm

Shaft diameter mm	Plummer block number	Dimensions mm													Oil filler / drain plug size	Reference dimension S	Mass kg			
		d	d ₁	d ₂	D	H	J	J ₁	N	N ₁	A	L	A ₁	A ₃				H ₁	H ₂	g
150	SV230	135	165	270	170	450	92	29	42	236	540	160	105	60	335	103	R1/4	M24	4	62
160	SV232	140	175	290	190	470	92	29	50	250	560	170	112	60	375	113	R1/4	M24	4	75
170	SV234	150	190	310	200	560	92	29	50	258	660	180	116	65	405	122	R1/4	M24	4	87
180	SV236	160	200	320	200	560	92	29	50	258	660	180	116	65	405	122	R1/4	M24	4	98
190	SV238	170	210	340	212	580	104	33	54	300	680	190	137	65	425	130	R1/4	M27	4	110
200	SV240	180	230	360	224	610	130	33	54	300	740	224	136	85	450	138	R1/4	M27	4	130
220	SV244	200	250	400	250	680	148	36	60	330	820	250	151	95	500	154	R1/4	M30	4	196
240	SV248	220	260	440	280	740	166	40	66	340	880	280	156	100	560	170	R1/4	M33	4	260
260	SV252	240	280	480	300	790	180	43	72	370	940	300	173	105	600	184	R1/4	M36	4	318
280	SV256	260	300	500	315	830	190	43	72	390	990	315	185	110	630	186	R1/4	M36	4	336
300	SV260	280	320	540	335	890	200	46	78	410	1060	335	196	115	670	202	R1/4	M39	4	433
320	SV264	300	340	580	355	930	215	49	84	440	1110	355	211	120	710	218	R1/4	M42	4	507

● Plummer Blocks

NTN

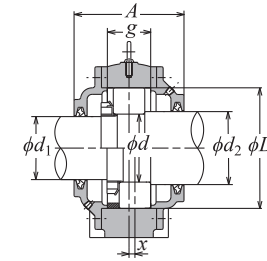

Shaft penetration type

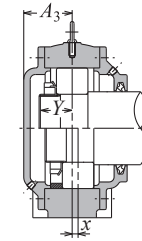

Shaft end type

Applied part		Reference dimension mm	Rubber seal number		Shaft dia. mm
Combination of self-aligning ball bearings	Combination of spherical roller bearings		d ₁ side	d ₂ side	
Bearing number	Stabilizing ring Number ¹⁾ Quantity	mm			
—	—	65	ZF30	GS37	150
—	—	76	ZF30	GS37	150
—	—	71	ZF32	GS39	160
—	—	83	ZF32	GS39	160
—	—	75	ZF34	ZF42	170
—	—	87	ZF34	ZF42	170
—	—	76	ZF36	ZF44	180
—	—	89	ZF36	ZF44	180
—	—	80	ZF38	ZF46	190
—	—	94	ZF38	ZF46	190
—	—	84	ZF40	GS50S	200
—	—	90	ZF44	ZF54	220
—	—	98	ZF44	ZF54	220
—	—	98	ZF48	ZF56	240
—	—	105	ZF48	ZF56	240
—	—	107	ZF52	ZF60	260
—	—	107	ZF52	ZF60	260
—	—	114	ZF56	ZF64	280
—	—	114	ZF56	ZF64	280
—	—	114	ZF60	ZF68	300
—	—	114	ZF60	ZF68	300
—	—	122	ZF64	GS72	320
—	—	122	ZF64	GS72	320

1) The stabilizing ring indicates the outside diameter and width dimension.
2) Dimension Y indicates the reference dimension from the shaft center to the end in the case of the shaft end shape.
Note: 1. SV220 or larger plummer blocks are provided with a lifting eye bolt.

Note: 2. Dimension x applies to plummer block numbers using one stabilizing ring and indicates the value of deviation from the bearing center to the plummer block center. The value is 1/2 of the width dimension of the stabilizing ring.