

## 1. Classification and characteristics of rolling bearings

### 1.1 Structure

Most rolling bearings consist of **rings with a raceway** (inner ring and outer ring), **rolling elements** (either balls or rollers) and a **cage** as shown in Fig. 1.1 (Fig. A through Fig. H). The cage separates the rolling elements at regular intervals, holds them in place within the inner and outer raceways, and allows them to rotate freely.

**Raceway (inner ring and outer ring) or raceway washer<sup>1)</sup> (shaft or housing)**

The surface on which rolling elements roll is called the **"raceway surface."** The load placed on the bearing is supported by this contact surface.

Generally the inner ring fits on the axle or shaft and the outer ring in the housing.

Note 1: The raceway of thrust bearings is called the "raceway washer," the inner ring is called the "shaft raceway washer" and the outer ring is called the "housing raceway washer."

### Rolling elements

Rolling elements are classified into two types: **balls** and **rollers**. Rollers come in four types: **cylindrical**, **needle**, **tapered**, and **spherical**. **Balls** geometrically contact with the raceway surfaces of the inner and outer rings at **"points"**, while the contact surface of **rollers** is a **"line"** contact. Theoretically, rolling bearings are constructed to allow the rolling elements to rotate orbitally while also rotating on their own axes at the same time.

### Cage

**Cages function to maintain rolling elements at a uniform pitch** so a load is never applied directly to the cage and to prevent the rolling elements from falling out when handling the bearing. Types of cages differ according to the way they are manufactured and include: **pressed**, **machined** and **formed cages**.

### 1.2 Classification

Rolling bearings are divided into two main classifications: **ball bearings** and **roller bearings**. Ball bearings are classified according to their bearing ring configurations: **deep groove type** and **angular contact type**. Roller bearings on the other hand are classified according to the shape of the rollers: **cylindrical**, **needle**, **tapered** and **spherical**. Rolling bearings can be further classified according to the direction in which the load is applied; **radial bearings** carry radial loads and **thrust bearings** carry axial loads. Other classification methods include: 1) number of rolling rows (**single**, **double**, or **4-row**), 2) **separable** and **non-separable**, in which either the inner ring or the outer ring can be detached.

There are also bearings designed for special applications, such as: precision rolling bearings for machine tools, bearings for special environments, as well as linear motion bearings (linear ball bearings, linear roller bearings and linear flat roller bearings). Types of rolling bearings are given in Fig. 1.2. For more detailed information, please refer to the page that introduces each bearing.

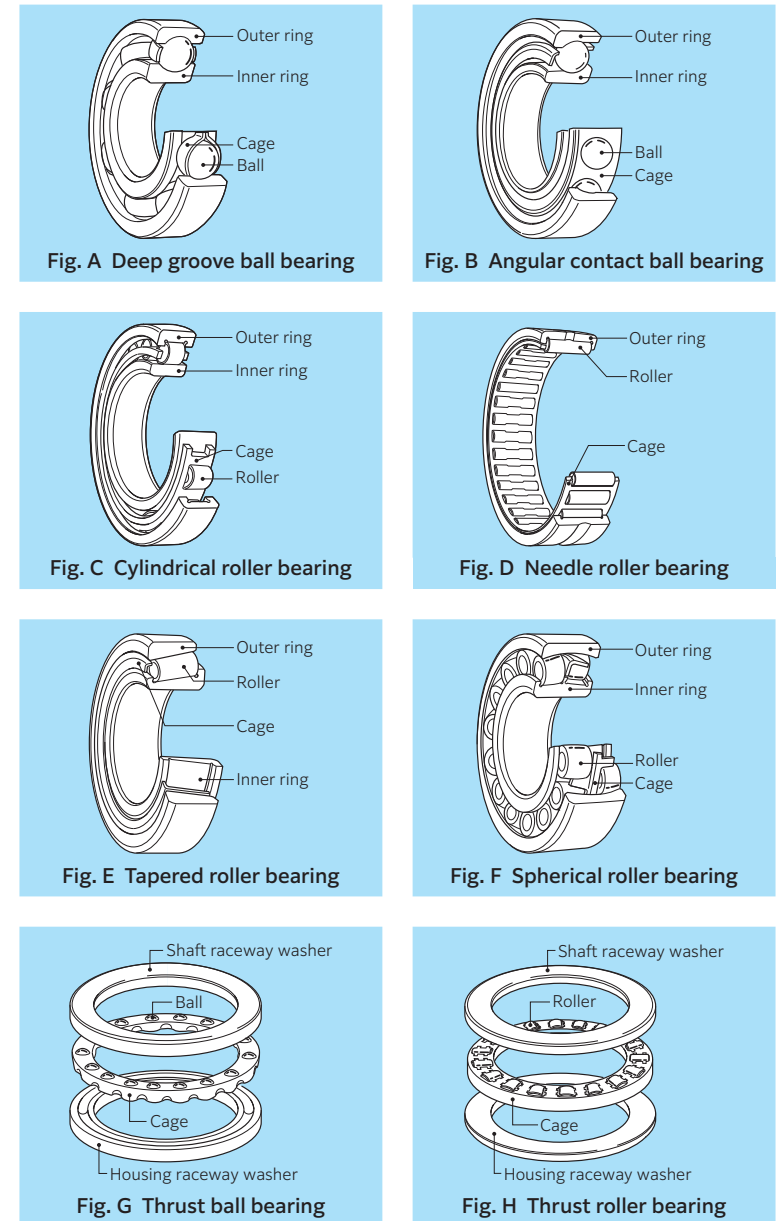

Fig. 1.1 Rolling bearing

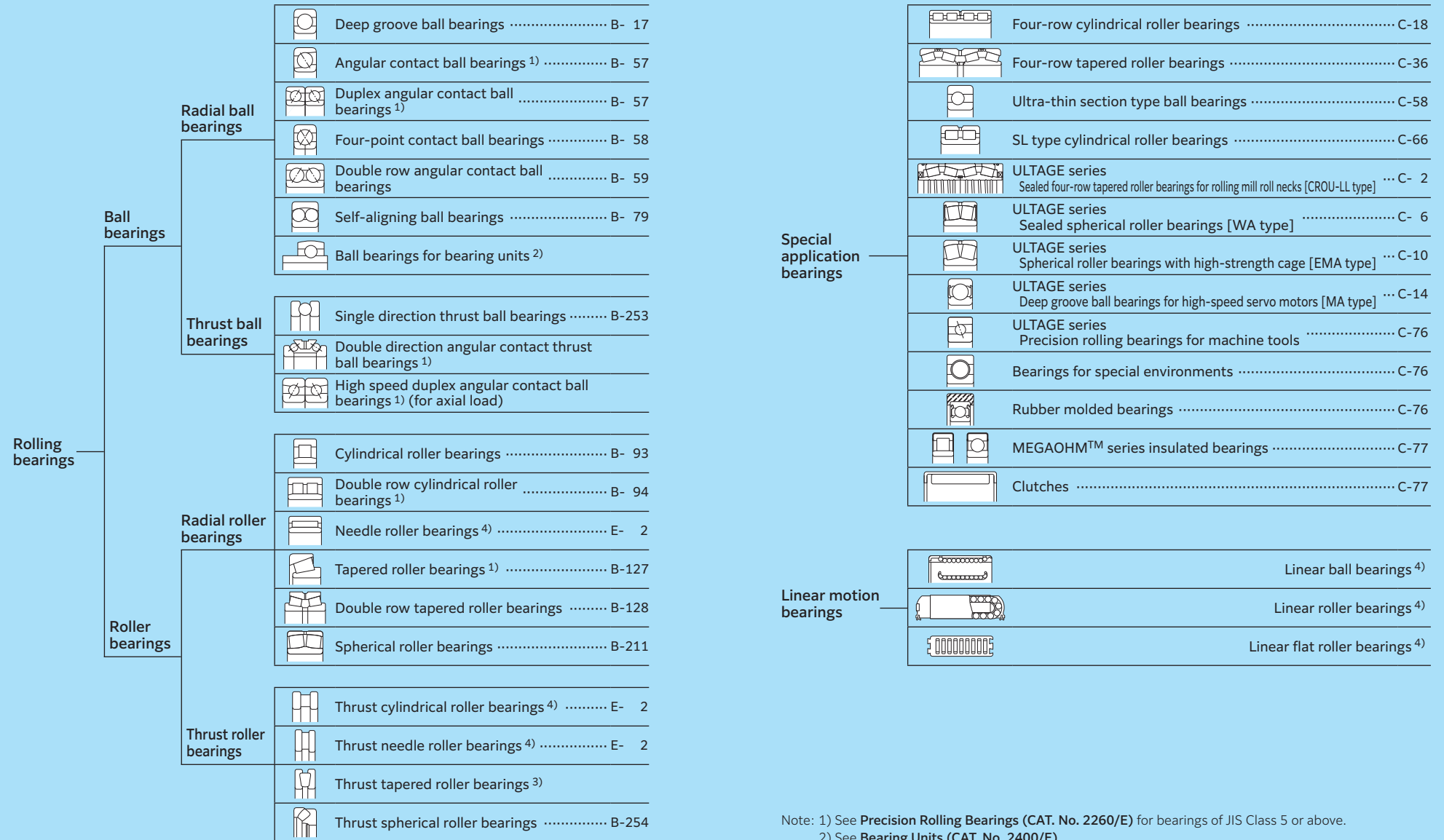

Fig. 1.2 Classification of rolling bearings

Note: 1) See Precision Rolling Bearings (CAT. No. 2260/E) for bearings of JIS Class 5 or above.  
 2) See Bearing Units (CAT. No. 2400/E).  
 3) See LARGE BEARINGS (CAT. No. 2250/E).  
 4) See Needle Roller Bearings (CAT. No. 2300/E).

## 1.3 Characteristics

### 1.3.1 Characteristics of rolling bearings

Rolling bearings come in many shapes and varieties, each with its own distinctive features. However, when compared with sliding bearings, rolling bearings all have the following advantages:

- (1) The **starting friction coefficient** is lower and there is little difference between this and the **dynamic friction coefficient**.
- (2) They are internationally standardized, **interchangeable** and readily obtainable.
- (3) They are easy to lubricate and consume less **lubricant**.
- (4) As a general rule, **one bearing** can carry both radial and axial loads at the same time.
- (5) May be used in either high or low temperature applications.
- (6) **Bearing rigidity** can be improved by **preloading**.

Construction, classes, and special features of rolling bearings are fully described in the boundary dimensions and bearing numbering system section.

### 1.3.2 Ball bearings and roller bearings

Table 1.1 gives a comparison of ball bearings and roller bearings.

**Table 1.1 Comparison of ball bearings and roller bearings**

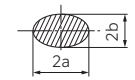
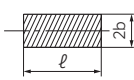
	Ball bearing	Roller bearing
Contact with raceway	 <p><b>Point contact</b> Contact surface is oval when a load is applied.</p>	 <p><b>Linear contact</b> Contact surface is generally rectangular when a load is applied.</p>
Characteristics	Because of point contact, where there is little rolling resistance, ball bearings are suitable for low torque and high-speed applications. They also have superior acoustic characteristics.	Because of linear contact, rotational torque is higher for roller bearings than for ball bearings, but rigidity is also higher.
Load capacity	Load capacity is lower for ball bearings, but radial bearings are capable of bearing loads in both the radial and axial direction.	Load capacity is higher for rolling bearings. Cylindrical roller bearings equipped with a lip can bear slight axial loads. Combining tapered roller bearings in pairs enables the bearings to bear an axial load in both directions.

### 1.3.3 Contact angle and bearing type

A contact angle is an angle made by a line that connects the contact point of the inner ring, rolling element, and outer ring in the radial direction when a load is applied on the bearing (see Fig. 1.3).

Bearings with a **contact angle of 45° or less** have a much greater radial load capacity and are classed as **radial bearings**; whereas bearings which have a contact angle over 45° have a greater axial load capacity and are classed as **thrust bearings**. There are also bearings classed as complex bearings which combine the loading characteristics of both radial and thrust bearings.

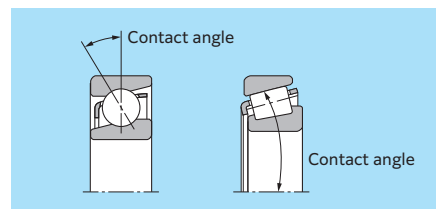

**Fig. 1.3 Contact angle**

### 1.3.4 Load acting on bearing

Types of loads applied on rolling bearings are given in Fig. 1.4. A moment load is caused by an unbalanced load and misalignment.

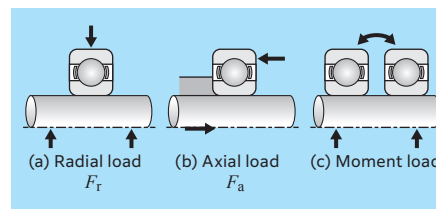

**Fig. 1.4 Types of load**

### 1.3.5 Standard bearings and special bearings

The boundary dimensions and shapes of bearings conforming to international standards are interchangeable and can be obtained easily and economically all over the world. It is therefore better to design mechanical equipment that can use standard bearings.

However, depending on the type of machine they are to be used in, and the expected application and function, a non-standard or specially designed bearing may be best. Bearings that are adapted to specific applications, and “unit bearings” which are integrated (built-in) into a machine's components, and other specially designed bearings are also available.

The features of typical standard bearings are as follows:

#### Deep groove ball bearing

The most common type of bearing, deep groove ball bearings are widely used in a variety of fields. Deep groove ball bearings can include shielded bearings or sealed bearings with grease to make them easier to use.

Deep groove ball bearings also include bearings with a locating snap-ring to facilitate positioning when mounting the outer ring, expansion compensating bearings which absorb dimension variation of the bearing fitting surface due to housing temperature, and TAB bearings that are able to withstand contamination in the lubricating oil.

**Table 1.2 Configuration of sealed ball bearings**

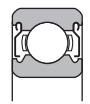
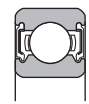
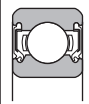
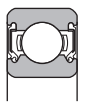
Type and code	Shielded type	Sealed type		
	Non-contact type ZZ	Non-contact type LLB	Contact type LLU	Low torque type LLH
Structure				

**Angular contact ball bearing**

The line that unites the point of contact of the inner ring, ball and outer ring runs at a certain angle (contact angle) in the radial direction.

Angular contact ball bearings are generally designed with three contact angles (see **Table 1.3**).

Angular contact ball bearings can support an axial load, but cannot be used by themselves because of the contact angle. They must instead be used in pairs or in combination (see **Table 1.5**).

Angular contact ball bearings include double row angular contact ball bearings for which the inner and outer rings are combined as a single unit (see **Table 1.4**). The contact angle of double row angular contact ball bearings is 25°.

There are also four-point contact bearings that can support an axial load in both directions by themselves. These bearings however require caution because problems such as excessive temperature rise and wear could occur depending on the load conditions.

**Table 1.3** Contact angle and codes

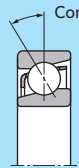

Contact angle and contact angle codes			
Contact angle	15°	30°	40°
Contact angle code	C	A <sup>1)</sup>	B

Note: 1. Contact angle code has been abbreviated as "A".

**Table 1.4** Configuration of double row angular contact ball bearings

Type and code	Open type	Shielded type ZZ	Non-contact sealed type LLM	Contact sealed type LLD
Structure				

**Table 1.5** Combinations of duplex angular contact ball bearings

Type and symbol	Back-to-back arrangement DB	Face-to-face duplex DF	Tandem arrangement DT
Structure			

$\ell$  : Distance between load centers

**Cylindrical roller bearing**

Cylindrical roller bearings use rollers for rolling elements, and therefore have a high load capacity. The rollers are guided by the ribs of the inner or outer ring. The inner and outer rings can be separated to facilitate assembly, and both can be fit with a shaft or housing tightly. If there are no ribs, either the inner or the outer ring can move freely in the axial direction. Cylindrical roller bearings are therefore ideal to be used as so-called "free side bearings" that absorb shaft expansion. In the case where there are ribs, the bearing can bear a slight axial load between the end of the rollers and the ribs. Cylindrical roller bearings include the HT type which modifies the shape of the roller end face and ribs for increasing axial load capacity, and the EA type and E type with a special internal design for enhancing radial load capacity. The EA type is standardized for small-diameter sizes.

**Table 1.6** shows the basic shapes.

In addition to these, there are cylindrical roller bearings with multiple rows of rollers and the SL type of full complement roller bearings without a cage.

**Table 1.6** Types of cylindrical roller bearings

Type code	Type NU Type N	Type NJ Type NF	Type NUP Type NH (NJ HJ)
Structure			

**Tapered roller bearing**

Tapered roller bearings are designed so the inner/outer ring raceway and apex of the tapered rollers intersect at one point on the bearing centerline. By receiving a combined load from the inner and outer ring, the rollers are pushed against the inner ring rib and are guided by the rib.

Induced force is produced in the axial direction when a radial load is applied, so it must be handled with a pair of bearings. The inner ring with rollers and outer ring come apart, thus facilitating mounting with clearance or preload. However, after assembly the clearance is hard to manage and requires special attention. Tapered roller bearings are capable of supporting large loads in both the axial and radial directions.

**NTN** also has a line of carburizing (case hardened) steel bearings designed for longer life (ETA-, etc.). **NTN** tapered roller bearings also include bearings with two and four rows of tapered rollers for extra-heavy loads.

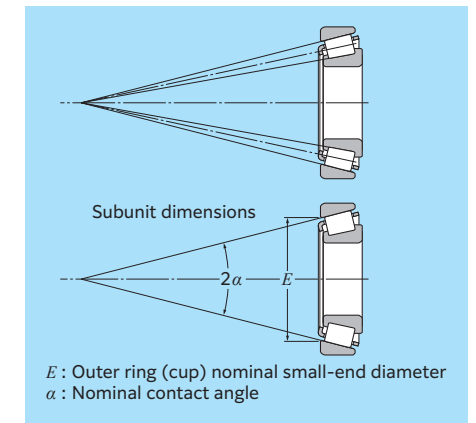

**Fig. 1.5** Tapered roller bearings

**Spherical roller bearing**

Equipped with an outer ring with a spherical raceway surface and an inner ring which holds two rows of barrel-shaped rolling elements, **NTN** spherical roller bearings are able to adjust center alignment to handle inclination of the axle or shaft.

There are a variety of spherical roller bearing types that differ according to their internal design.

In addition to cylindrical bore inner rings, spherical roller bearings can be produced with a tapered bore inner ring. The tapered bore bearing can easily be mounted on a shaft by means of an adapter or withdrawal sleeve. The bearing is capable of supporting heavy loads, and is therefore often used for industrial machinery. When a heavy axial load is applied to the bearing, the load on rollers of one row is not applied, and can cause problems. Attention must therefore be paid to operating conditions.

**Table 1.7 Types of spherical roller bearings**

Type	ULTAGE series		
	Type EA	Type EM	Type EM (large size)
Structure			
Type	Type B	Type C	Type 213
Structure			

**Thrust bearing**

There are many types of thrust bearings that differ according to the shape of the rolling element and application.

Allowable rotational speed is generally low and special attention must be paid to lubrication.

In addition to the types shown in **Table 1.8** below, there are various other types of thrust bearings for special applications.

**Table 1.8 Types of thrust bearings**

Type	Single direction thrust ball bearings	Thrust needle roller bearings
Structure		 AXK type  AS type raceway washer  GS/WS type raceway washer
Type	Thrust cylindrical roller bearings	Thrust spherical roller bearings
Structure		 Allowable angle

**Needle roller bearing**

Needle roller bearings use needle rollers as rolling elements. The needle rollers are a maximum of 6 mm in diameter and are 3 to 10 times as long as they are in diameter (JIS B 1506 rolling bearings roller). Because the bearings use needle rollers as rolling elements, the cross-section is thin, but they have a high load capacity for their size. Due to the large number of rolling elements, bearings have high rigidity and are ideally suited to oscillating motion.

There are various types of needle roller bearings, and just a few of the most representative types are covered here. For details, see the special catalog “**Needle Roller Bearings (CAT. No. 2300/E).**”

**Table 1.9 Main types of needle roller bearings**

Type	Needle roller bearing with cage
Structure	
Type	Solid type needle roller bearings
Structure	
Type	Drawn cup needle roller bearings
Structure	
Type	Cam follower    Roller follower
Structure	

**Bearing unit**

A unit comprised of a ball bearing inserted into various types of housings. The housing can be bolted onto machinery and the inner ring can be easily mounted on the shaft with a setscrew.

This means the bearing unit can support rotating equipment without a special design to allow for mounting. A variety of standardized housing shapes are available, including pillow block and flange types. The outside diameter of the bearing is spherical just like the bore diameter of the housing, so it is capable of aligning itself on the shaft.

For lubrication, grease is filled inside the bearing, and foreign particles are prevented from entering with a shaft riding seal and slinger shield.

For details, see the special catalog “**Bearing Units (CAT. No. 2400/E).**”

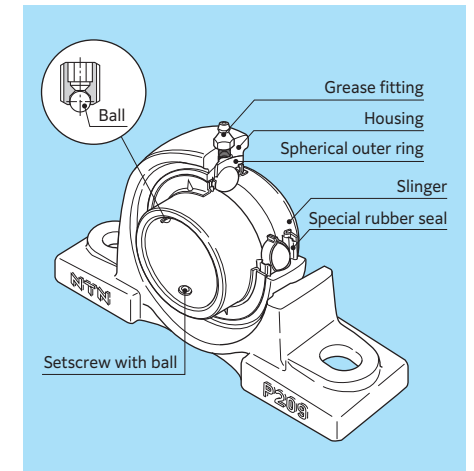

**Fig. 1.6 Bearing unit with grease fitting**