

For New Technology Network

NTN[®]

NTN Corporation



NTN Report 2014

for the year ended
March 31, 2014



Profile

Aerospace
Jets, rockets, and satellites around the world



Agricultural machinery
Agricultural machinery worldwide



Wind turbine
Land-based and offshore wind turbines



Construction machinery
Resource mining and civil engineering



Medical equipment
CT scanners and artificial hearts



Rolling stock
High-speed railways around the world



Machine tool
High-speed-rotation machinery

Industrial Machinery Applications

Enabling high performance in the rotating parts of a range of industrial machinery



Creative Technology Supports Worldwide Industry and Energy-Saving Lifestyles

Outline (as of March 31, 2014)

Corporate name: NTN Corporation

Trademark: NTN

Date founded: March 1918

Head Office:

3-17, 1-chome, Kyomachibori, Nishi-ku,
Osaka 550-0003, Japan

Representative:

Hiroshi Ohkubo, President

Number of employees:

Consolidated: 22,156

Non-consolidated: 5,050

Fiscal term: March

Capitalization: 54.3 billion yen

Net Sales:

Consolidated: 639.0 billion yen

Non-consolidated: 321.4 billion yen

Editorial Policy

NTN believes the active disclosure of management plans and business results, as well as its basic policy for corporate social responsibility (CSR), CSR activities, and environmental preservation initiatives, among other information, will help garner the understanding and support of all stakeholders. This "NTN Report," which since the fiscal year ended March, 31 2010 has combined the "Annual Report" and the "CSR Report," is part of this active approach to information disclosure. This report has been edited with reference to the International Integrated Reporting Framework of the International Integrated Reporting Council.

Forward Looking Statements

This report contains forecasts and projections regarding NTN's future plans, strategies, and business results. Please understand that actual business results may vary from the projections made herein by the Company.

Automotive drive system
More compact and lightweight transmissions that are fuel efficient and safe



Automotive Applications

Contributing to energy saving of automobile through more compact, lighter weight and lower torque

EV system
In-wheel Motor System, various module products



Automotive wheel
Better fuel efficiency and a more comfortable ride



Sale of automotive repair parts (auto parts)
Expanding business in Europe, the Americas, and Asia

Aftermarket Applications

Meeting the maintenance needs in the industrial machinery and automotive applications

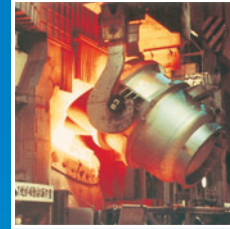

MRO (Maintenance, Repair, and Overhaul) business
Maintenance and replacement of bearings



Product training
Training on choosing optimal bearings and their proper use



Technical support
Mobile training units offer technical services for customers

* Photos are cross-sectional models of products.

Provides People Everywhere with Safe, Dependable,



CONTENTS

Financial Highlights 3
 Non-Financial Highlights 5
 NTN's Strengths 7
 To Our Stakeholders 9
 Interview with the Top Management 11

Feature:
Medium-Term Management Plan "Revival 2014" – Progress and Future 17

1. Emergency Measures 18
 Short-Term Measures to Generate Profit

2. Centralization of Management Resources 18
 Centralization on Priority Fields

3. Structural Reform 20
 Mid-Term Business Structural Reform

4. Expansion of New Products and New Business 21
 Towards Further Growth

At a Glance 23

Aftermarket 25
 Industrial Machinery Market 27
 Automotive Market 29

Research and Development 31

CSR Activities Report 32

Corporate Governance 33
 Focus 41
 Social and Environmental Responsibility 44

Third-Party Opinion 61
 Financial Section 62
 Report of Independent Auditors 89
 Investor Information 90
 Global Network 91

Financial Highlights

NTN Corporation and consolidated subsidiaries

Net sales

639 billion yen

(Billions of yen)

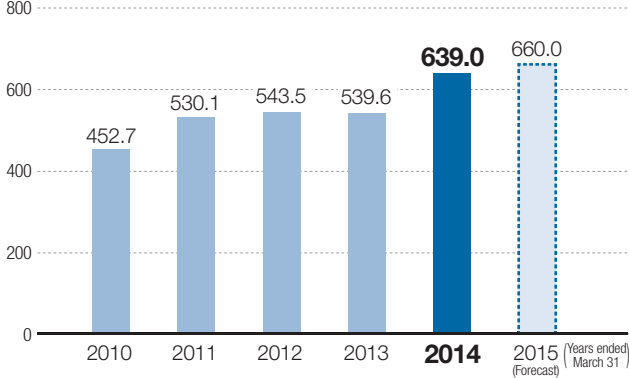

Operating income

33 billion yen

(Billions of yen)

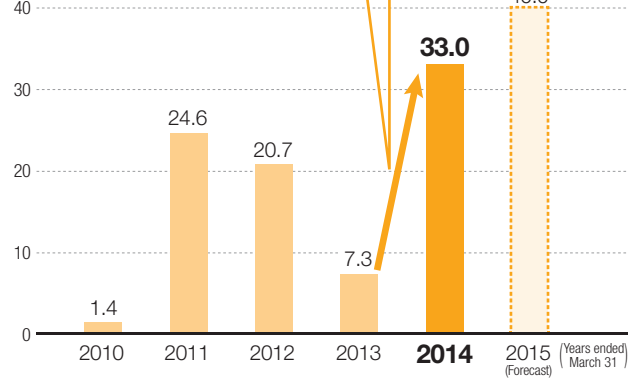

Inventories / Inventory turnover ratio

Inventories **166.5** billion yen
Inventory Turnover Ratio **3.8** times

(Billions of yen)

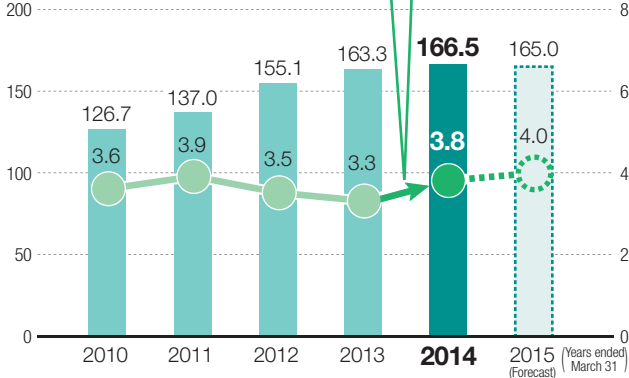

Operating margin

5.2%

(%)

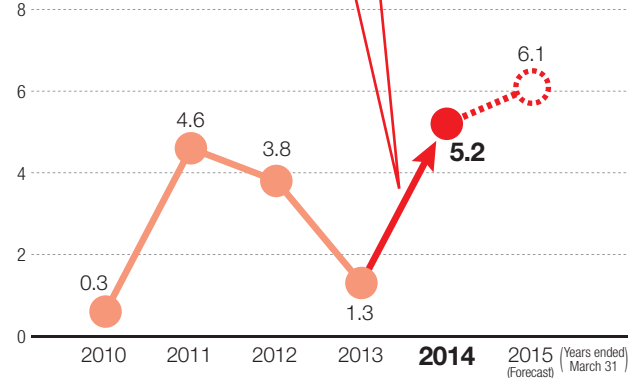

Percentage of net sales by business sector

Aftermarket **16%** Industrial Machinery **16%** Automotive **68%**

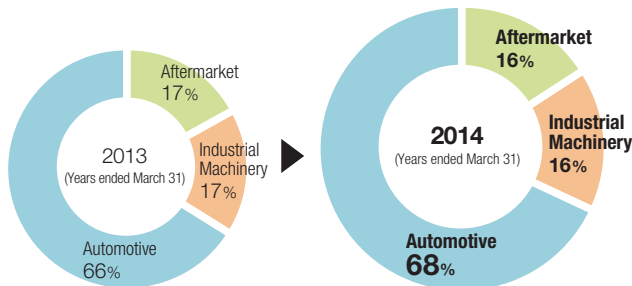

Percentage of net sales by region

Overseas sales ratio **72%**

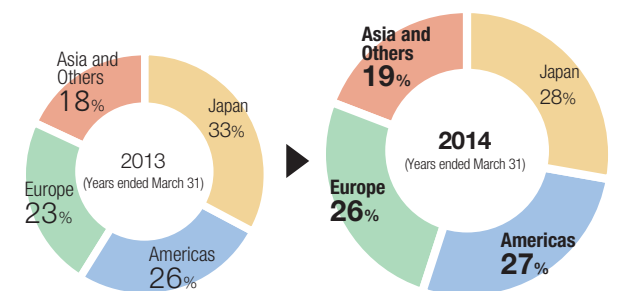

Net income (loss)

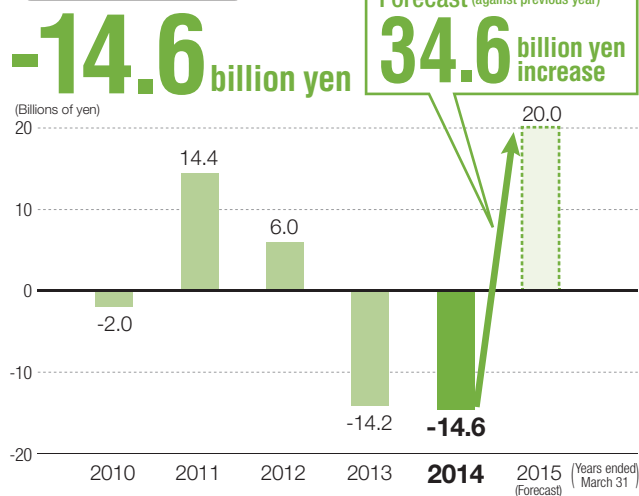

Capital expenditures / Depreciation

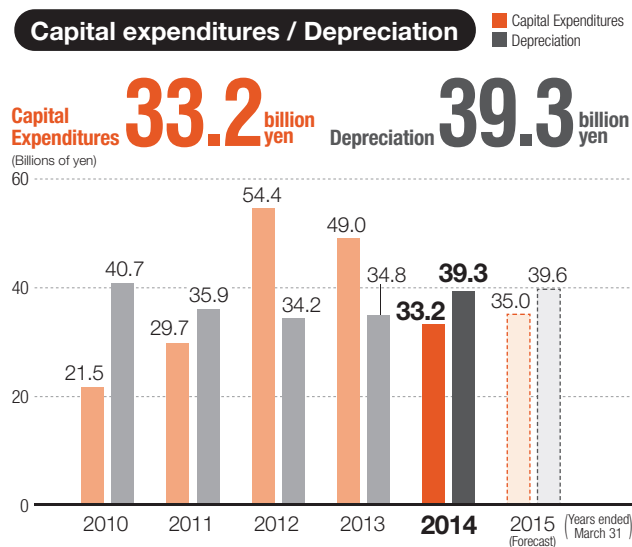

Net income / Average total assets (ROA)

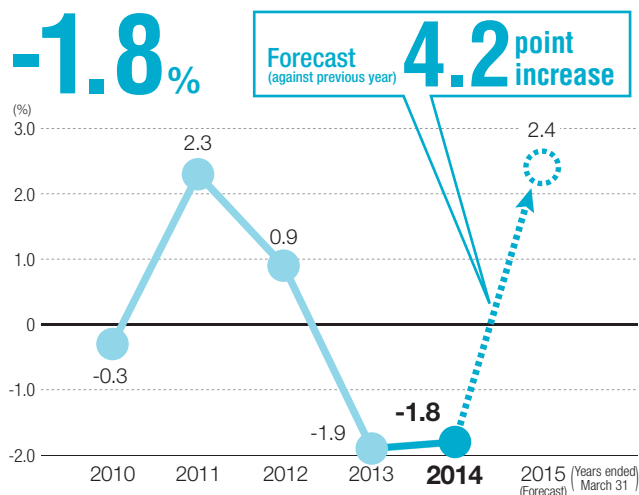

Net income / Average shareholders' equity (ROE)

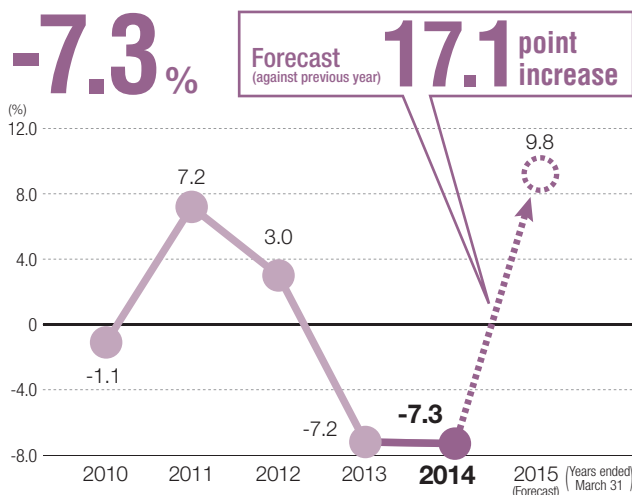

Net D/E ratio

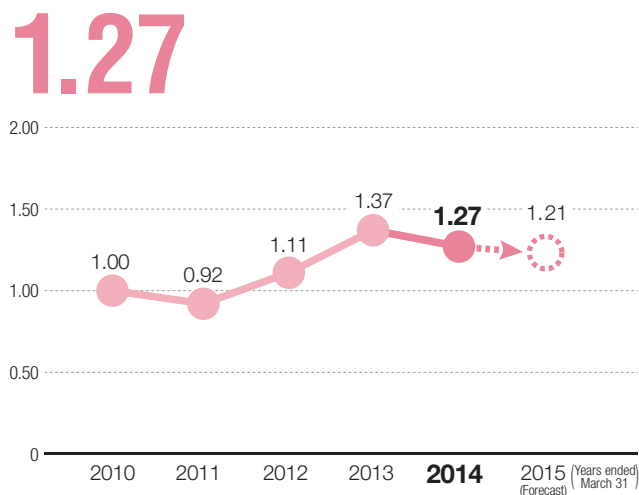

NTN-ROI*

* NTN-ROI = Net operating income after tax / (Inventories + tangible fixed assets)

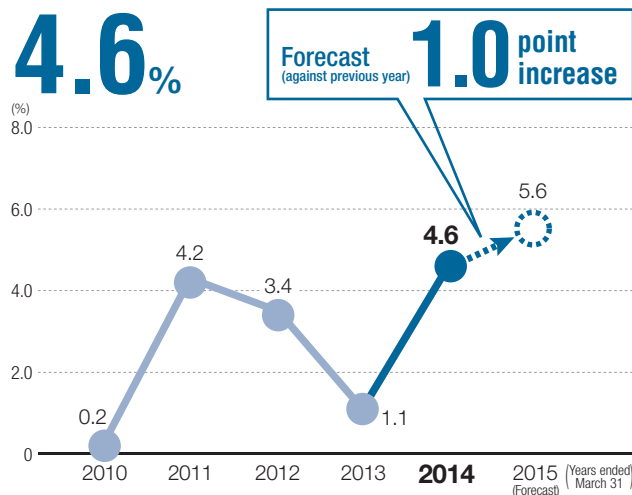

Non-Financial Highlights

Based on the International Integrated Reporting Framework of the International Integrated Reporting Council.

Manufacturing capital



Local procurement ratio

84%

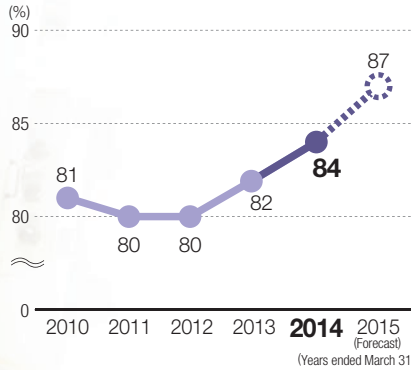

Overseas production ratio

49%

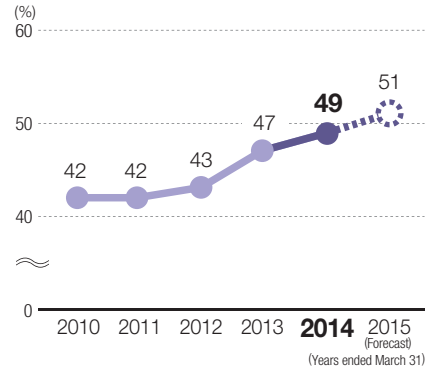

Natural capital

Total CO₂ emissions: Based on fixity coefficient (0.381) (See page 56.)

Total CO₂ emissions

(NTN group companies in Japan)

272,000 tons/year

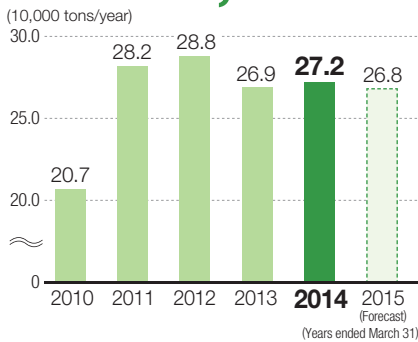

Electricity consumption

(NTN group companies in Japan)

496 GWh

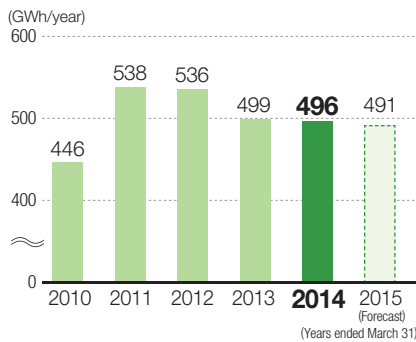

Landfill waste

(NTN group companies in Japan)

480,000 tons/year

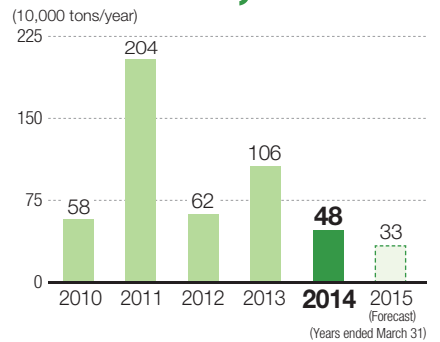

Human capital



Percentage of employees overseas

64%

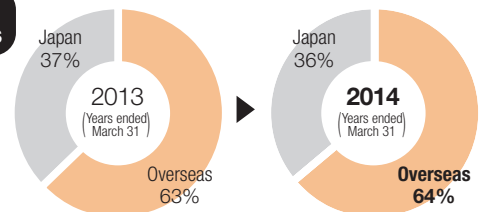

Percentage of female managers

(NTN Corporation only)

3.4%

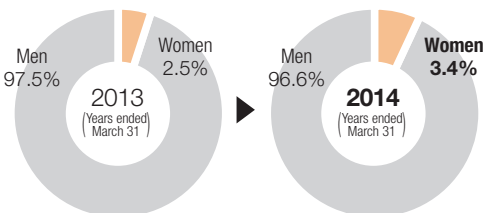

Intellectual capital



Ratio of R&D expenditures to net sales

■ R&D Expenditures (Billions of yen) ● Ratio of R&D Expenditures to Net Sales (%)

R&D Expenditures 17.8 Billions of yen
Ratio of R&D Expenditures to Net Sales 2.8%

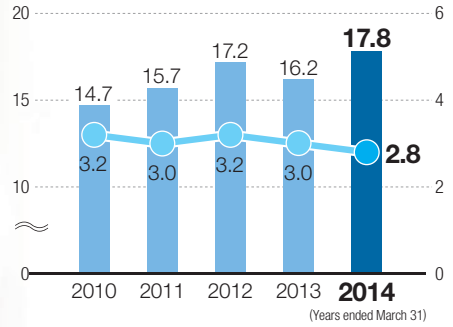

Water usage

(NTN group companies in Japan)

1,930,000 m³/year

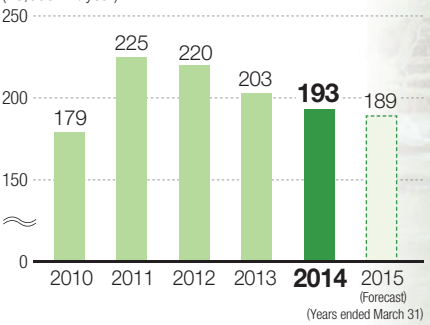

Social capital

Overall assessment of customer satisfaction surveys

(NTN group companies in Japan)

“Very good” and “Good” accounted for 89%

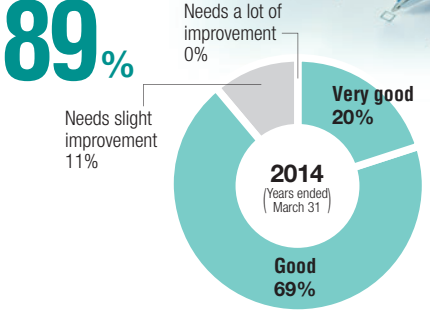

NTN included in SRI Indices

Dow Jones Sustainability Asia Pacific Index
FTSE4 Good Global Index
Morningstar Socially Responsible Index

MEMBER OF
Dow Jones Sustainability Indices
 In Collaboration with RobecoSAM



FTSE4Good



Only NTN Can Do It

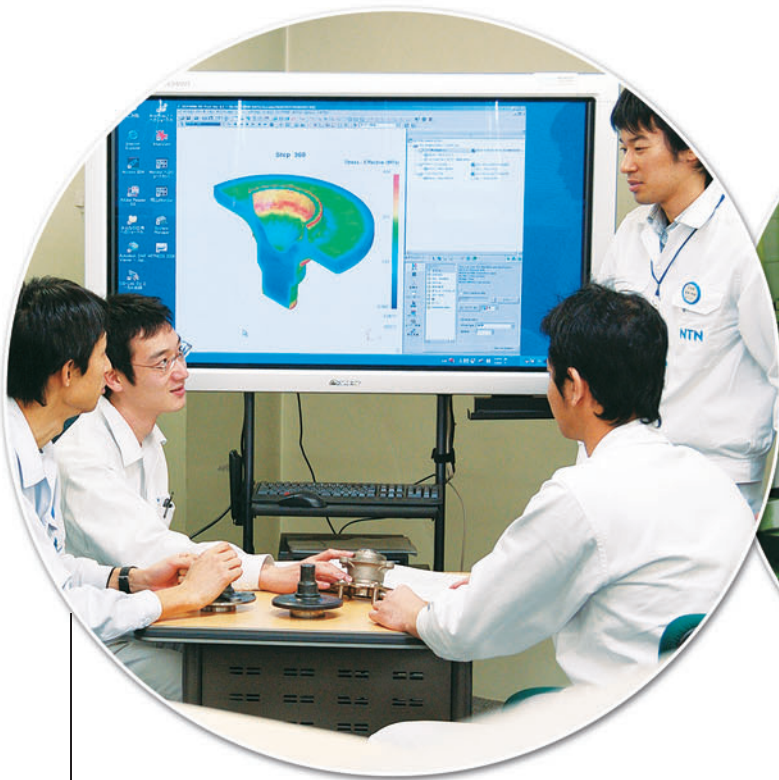

Research and Development

Developing High-Value-Added System Products that Incorporate Proprietary Materials, Design Technology, and Electronic Control

Key themes of NTN's research and development include "environmental protection" and "new energy contributions." In recent years, we have been moving from individual components to module and system products as we come out with products with increasingly higher added-value.

Procurement, Production

Meeting Customer Needs around the World through Local Procurement, Local Production, and Local Provision

NTN's production system is geared to meeting regional needs around the world. A consistent local manufacturing system from material procurement all the way to assembly of finished products shortens production lead time, reduces inventory of products in process, and lowers material costs.

Development system

Worldwide **4** R&D bases
(Japan, Americas, Europe, China)

R&D as percentage of net sales

2.8%
(Fiscal year ended March 31, 2014)

4 Worldwide R&D Bases

- ADVANCED TECHNOLOGY R&D CENTER
- PRODUCTION ENGINEERING R&D CENTER
- NTN R&D CENTER
- INDUSTRIAL TECHNICAL CENTER

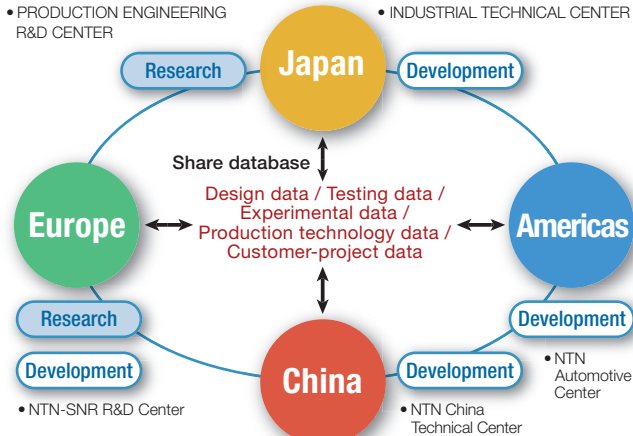

Local procurement ratio

84%
(Fiscal year ended March 31, 2014)

Local procurement ratio (%)

(Compared to 10 years ago)

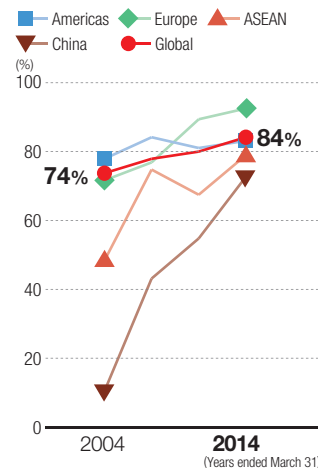

Overseas production ratio

49%
(Fiscal year ended March 31, 2014)

Overseas production ratio (%)

(Compared to 10 years ago)

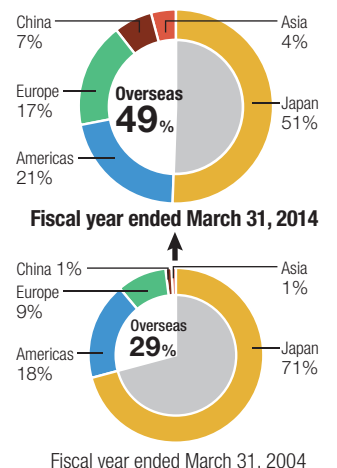



Sales

Doing Business with Many Car and Industrial Machinery Manufacturers through a Global Sales Network

With a system of three business headquarters (Aftermarket, Industrial Machinery, and Automotive), 37 sales bases in Japan and 94 overseas, and a network of distributors stretching around the world, we have an increasing number of sales channels through which to market and sell our products. We are improving our IT-driven sales system for distributors so that we can further improve our service.

Extreme Environments

Providing Products that Withstand Harsh Conditions in Industries Such as Aircraft and Space

NTN is certified to supply the world's four major jet engine manufacturers with bearings that are used in the engines of jumbo jets, where temperatures reach 200°C. We also provide products to a large number of high-speed railways worldwide, whose trains operate at speeds of over 250km/h.

Share of world market

Overseas sales ratio



Aircraft

Rolling stock



Hub bearings*

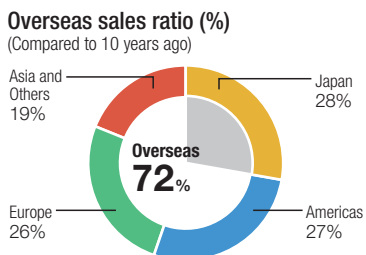

Constant-velocity joints

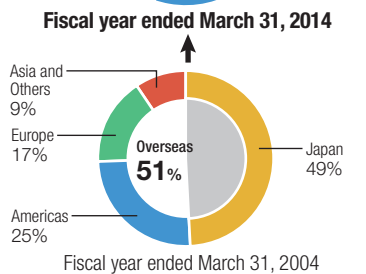

Aircraft

TGV (France's high-speed rail service)



* Photos are cross-sectional models of products.

Taking on Challenges Under a New System in Aiming for the Next Stage of Growth



President's Message

My name is Ohkubo, recently appointed as the President of NTN. I plan on addressing the various issues that are present today with a sense of speed and a spirit of challenge in order to complete the two-year Medium-term Management Plan "Revival 2014," which has been implemented since April 2013. We also are aiming for continued growth through 2018, the year that the company celebrates its 100th anniversary since foundation, and well into the future.

I look forward to your understanding and support of NTN's future efforts as we prosper together in exciting new business fields.

President

History

1977: Joined NTN
1985: NTN USA Corp.
1995: Accounting Department
1996: NTN-BCA Corp.
2004: Deputy Manager,
Finance Department
2005: NTN Europe Corp.
2010: Executive Officer
2012: Director
2013: Managing Director
June 2014: President

Corporate Philosophy

“We shall contribute to international society through creating new technologies and developing new products.”

For New Technology Network

1. Creation of original technologies.
2. Offering the technologies for additional values and service that are suitable for each customer and end user.
3. Improvement of employees' standard of living, distribution of fair returns to stockholders, and contribution to society based on the steady growth of our business.
4. Promotion of globalization, and formation of management systems / corporate organization which are essential for NTN, as an international leading company.

NTN's Accomplishments and Challenges

The NTN Group has made compliance a top priority and is striving to strengthen its systems for complying with laws and regulations including Anti-Monopoly and competition laws. NTN management expresses gratitude to all relevant personnel including the shareholders for their understandings and their professional efforts during the past period related to recent investigations regarding Anti-Monopoly and competition law issues in areas including Japan, Europe, and Singapore. The NTN Group will continuously strengthen the system to thoroughly comply with laws and regulations, social norms, ethics, and in-house regulations on a global basis, thereby further promoting business activities through fair and sincere competition.

During the fiscal year under review, the Japanese economy saw a moderate recovery reflecting the downward revision of the yen and other factors. Looking at the overseas economy, the U.S. economy continued a moderate recovery, the European economy was also picking up gradually, and the Chinese economy achieved a stable economic expansion, while other emerging countries saw a continuing slump in their economic condition.

In such an environment, the NTN Group is aiming to “reform business structure to generate profit” as part of the group's two-year Medium-term Management Plan “Revival 2014.” To

achieve this, NTN has been implementing various policies such as expanding sales in the highly profitable aftermarket and the industrial machinery market, and improving profits of the automotive business based on the three core businesses - the Aftermarket Business Headquarters that was established last year, the Industrial Machinery Headquarters, and the Automotive Business Headquarters.

Growth Efforts

We follow our Corporate Philosophy in conducting a range of efforts aimed at attaining medium- and long-term growth.

NTN aims to ensure ongoing profits by further increasing business profitability and efficiency of assets, and by strengthening the financial structure essential to ensure stable returns to all stakeholders. As a company formed around the concept of monozukuri, NTN will always remain at the forefront of developing innovative new technologies and will back these actions up with specific developments in monozukuri and hitozukuri (personnel development). Social responsibility, such as compliance with legal standards and conservation of the global environment, forms the backbone of a global company, and will be strengthened even further as the foundation for the Group's management.

The NTN Group would like to take this opportunity to ask for the continued support of our stakeholders.

Overall performance in the fiscal year ended March



Q1 What is the current situation with NTN and the Anti-Monopoly Act, and what is your policy on ensuring thorough compliance?

A We have strengthened our control systems in Japan and overseas in order to reconfirm that we are abiding by all laws and regulations.

In June 2012, we received an indictment filed by the Tokyo District Prosecutors Office (TDPO) on suspicion of having violated the Japan Anti-Monopoly Act in relation to the domestic sale of bearings, and in March 2013, we received a cease and desist order and surcharge payment order (for 7.231 billion yen) from the Japan Fair Trade Commission (JFTC). Because the assertions by the JFTC and TDPO are greatly different from the company's views of the facts, we appealed the JFTC's orders. And we are presenting a defense of the Company during the trial.

In March 2014, we underwent settlement procedures under EU competition law, and we received a notification to the effect that it imposes fines of 201,354 thousand euros (yen equivalent of 27,023 million yen at the average rate during the consolidated fiscal year ended March 31, 2014) on suspicion that our European Group Companies violated the EU Competition Law. And we estimated a loss expected to occur in the future and included 35 million yen in extraordinary loss for the consolidated fiscal year ended March 31, 2014 against the progress of an investigation of the Competition Commission of Singapore. In May 2014, we and our consolidated subsidiary in Singapore received a decision from the Competition Commission of Singapore to the effect that it imposes fines of 455 thousand Singapore dollars (yen equivalent of 37 million yen at the average rate during the current consolidated first quarter).

There are ongoing investigations of the bearing industry by the United States Department of Justice and the Korea Fair Trade Commission but no charges against the company or its subsidiaries have been filed in those jurisdictions. And we and our subsidiaries in the U.S. and Canada are defendants in a number of class action suits.

Our management expresses gratitude to all relevant personnel

including the shareholders for their understanding and their professional efforts during the past period.

As for our management system in Japan and overseas, in April 2014, the Company newly established the CSR Headquarters with the aim of strengthening a system for supervising the sections (CSR Department, Legal Department, Fair Trade Promoting Department) involved in the corporate social responsibility, developing global activities, and pursuing compliance with legal norms and social responsibilities throughout the Group. Overseas, the Company also newly launched the Internal Control Section within general managers' offices in each overseas region in a bid to build and strengthen compliance systems, including the strengthening of efforts to ensure compliance with the Anti-Monopoly Act. Using this new management system, the NTN Group will work as one to ensure compliance with laws and the thorough implementation of CSR.

Q2 What was the market environment and performance in the fiscal year ended March 31, 2014?

A Net sales and operating income both made significant improvements.

In the fiscal year ended March 31, 2014, the Japanese economy enjoyed moderate recovery thanks to factors including a correction in the value of the yen. While newly emerging countries continued to grow slowly, the U.S. enjoyed moderate recovery, Europe bounced back, China steadied off, and the result was an overall favorable market environment.

Against this background, the NTN Group has been implementing numerous measures with the aim of "Reforming Business Structure to Generate Profit" under our "Revival 2014" medium-term management plan, which we launched in April 2013. The result was net sales of 639 billion yen (up 18.4% over the previous year), a dramatic improvement over the previous year. On the profit side, operating income was 33 billion yen (up 353.5% over the previous year) and ordinary profit was 28.7 billion yen (against 2.5 billion the previous year), both representing drastic improvements.

However, apart from 27 billion yen in losses related to the Anti-Monopoly Act, which was calculated as an extraordinary loss, there were 2 billion yen in impairment losses, 1.6 billion yen for provision of reserve for losses on support of affiliates, and 1.4 billion yen in reorganization expenses, all of which added up to a net loss for the fiscal year of 14.6 billion (against a 14.2 billion yen net loss last year).

Q3 What was the situation in each region and what measures did you take?

A We were able to increase sales and profits in all world regions.

In Japan, sales were down for industrial machinery applications

31, 2014 and medium-term management plan

but were up in the automotive applications due to increased customer demand; the result was overall net sales in Japan of 323.6 billion yen, little changed from the previous year (up 2.4% over the previous year). In operating income, meanwhile, the effect of exchange rates and a decrease in fixed costs such as labor resulted in a large increase in profits, with operating income of 25.6 billion yen (up 160.2% over the previous year).

In the Americas, sales were up overall in the aftermarket applications and automotive applications, and exchange rate effects were positive, resulting in net sales of 171.8 billion yen (up 24.1% over the previous year). Operating income was 2.6 billion yen (against the loss of 3.2 billion yen booked in the same period in the previous year), primarily due to the elimination of temporary costs resulting from an additional burden imposed on production lines in coping with increased sales to the automotive applications in the previous year.

In Europe, net sales were 182.4 billion yen (up 33.5% over the previous year), due to increases in the aftermarket and automotive

applications driven by a recovery in customer demand, as well as the effects of exchange rates. Operating income was 2.1 billion yen (against the loss of 0.2 billion yen booked in the same period in the previous year), driven by increased sales.

In Asia, while the aftermarket and industrial machinery applications dropped, a recovery in business with Japanese manufacturers in China in the automotive market, newly started production from new orders, and the effect of exchange rates resulted in net sales of 113.8 billion yen (up 32.7%). Operating income was up significantly to 4.4 billion yen (up 517.8%) thanks to the effects of increased sales.

Q4 What kind of market environment and business performance do you forecast for the fiscal year ending March 31, 2015?

A We are aiming to continue increasing sales and profits by implementing measures under “Revival 2014”.

For the fiscal year ending March 31, 2015, we expect the U.S.

Performance in the Fiscal Year Ended March 31, 2014 and Forecast for the Fiscal Year Ending March 31, 2015

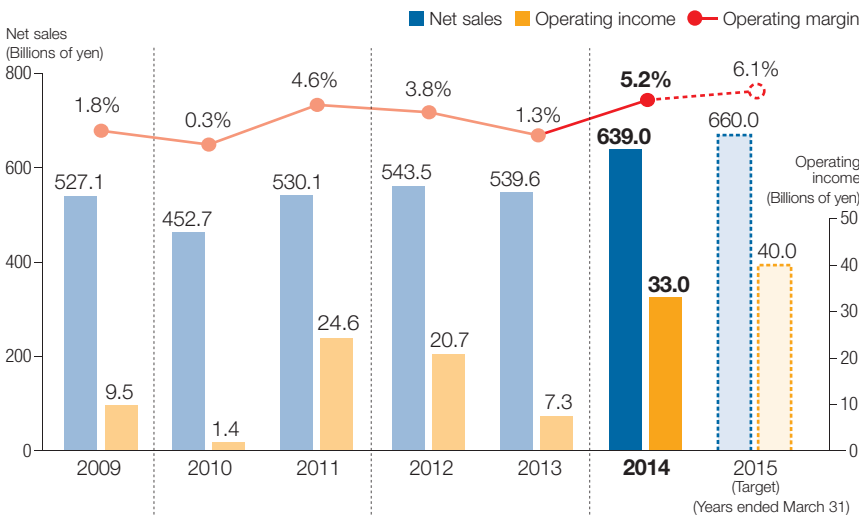

Fiscal year ended March 31, 2014 (Results)
 Net sales: **639** billion yen
 Operating income: **33** billion yen
 Operating margin: **5.2%**
 Net income: **-14.6** billion yen
 Full-year dividend: **2** yen (resumed)

Accomplish “Revival 2014”

Fiscal year ending March 31, 2015 (Forecast)*
 Net sales: **660** billion yen
 Operating income: **40** billion yen
 Operating margin: **6.1%**
 Net income: **20** billion yen
 Full-year dividend: **5** yen

Note: Exchange rate for fiscal year ending March 31, 2015: 1\$US=¥100 yen, 1€=¥130

Continue “Reforming Business Structure to Generate Profit”

Interview with the Top Management

and European economies to make a moderate recovery. However, Japan may feel the effects of a higher consumption tax and uncertainty looks to continue in emerging economies. In this situation, in the second year of our “Revival 2014” medium-term management plan we will continue implementing numerous measures under our basic policy of “Reforming Business Structure to Generate Profit.”

By carrying out these various measures, our forecast for the entire fiscal year ending March 31, 2015 calls for net sales of 660 billion yen (up 3.3% over the previous year), operating income of 40 billion yen (up 21.2% over the previous year), ordinary profit of 33 billion yen (up 15.1% over the previous year), and net profit of 20 billion yen (against the loss of 14.6 billion yen booked in the same period in the previous year). Performance estimates for the fiscal year ending March 31, 2015 are based on an exchange rate of 1\$US=¥100 yen, 1€=¥130.

Note: Consolidated subsidiaries of the Company in the United States and South Korea have been investigated by the respective authorities in relation to competition law, and multiple civil action lawsuits (class action lawsuits) have been launched against the Company and its American and Canadian consolidated subsidiaries. As such, this situation has not been taken into consideration in the above forecast.

Q5 What will be the dividend for the fiscal year ended March 31, 2014?

A The dividend was 2 yen per share.

The NTN Group considers rewarding its shareholders an

issue of foremost importance. Regarding dividends, from a medium- and long-term perspective, the Company’s goal is to provide a steady and sustainable dividend, which it will determine on the basis of its consolidated performance, dividend payout ratio, and business environment.

The dividend for the fiscal year ended March 31, 2014 was undecided at first, but based on performance trends and an overall assessment of factors including the management environment, we have decided to resume the dividend at 2 yen per share. As for the dividend for the fiscal year ending March 31, 2015, we intend to pay 5 yen per share (interim dividend of 2.5 yen, year-end dividend of 2.5 yen).

Q6 How is “Revival 2014” progressing?

A We are working to reform business structure to generate profit through the three key pillars of “Improving profitability,” “Improving asset efficiency,” and “Better management framework.”

The NTN Group embarked upon its two-year medium-term management plan, “Revival 2014,” to cope with changes in the business environment. Based on the plan’s basic policy of “Reforming business structure to generate profit,” we are pursuing profit-making in four key ways: carry out emergency measures, centralize management resources, carry out structural reform, and expand new products and new business.

Progress of Medium-Term Management Plan “Revival 2014”

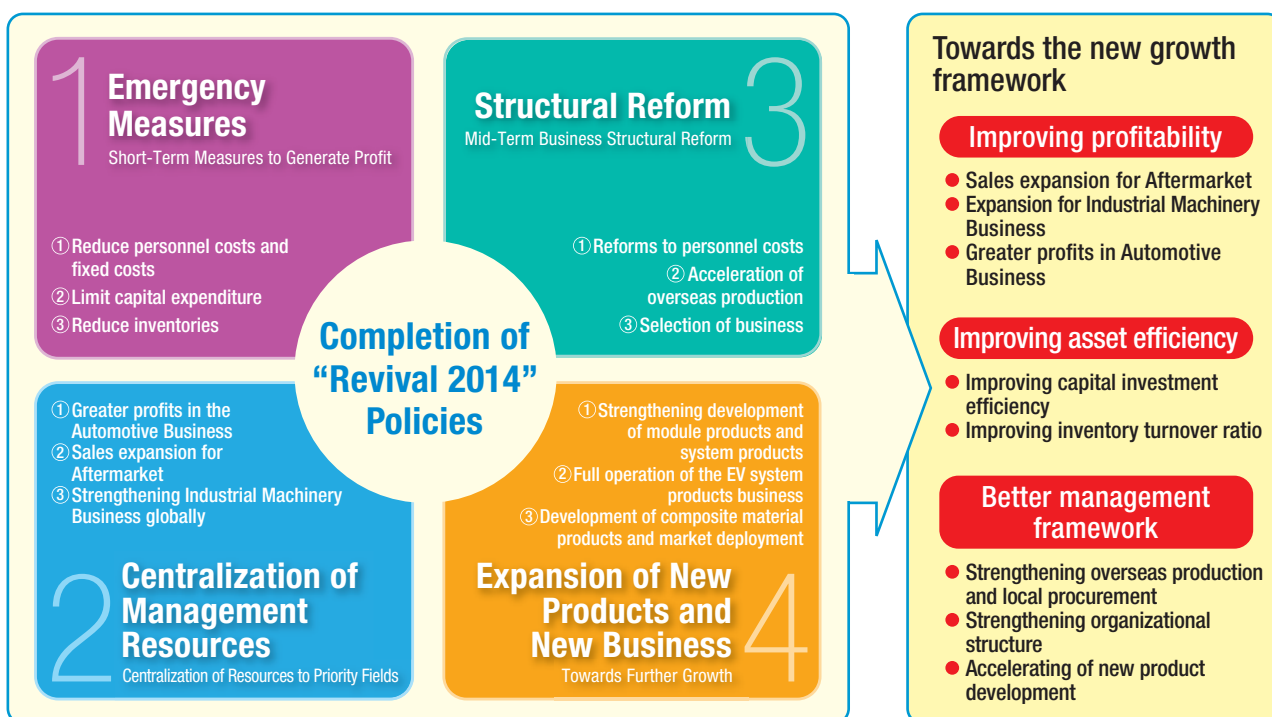

These will allow us to achieve the new growth pillars of improving profitability, improving asset efficiency, and better management framework, and thus realize the main goal of “Revival 2014”: “Reforming Business Structure to Generate Profit.”

Below is an overview of progress on the aforementioned three key pillars of “Revival 2014.”

Progress in “Improving Profitability”

- **We are stepping up efforts to achieve greater profits in the automotive applications, and to strengthen aftermarket applications and industrial machinery applications.**

For two consecutive years starting in the fiscal year ended March 31, 2012, the automotive business was in the red, and improving profitability there is a top priority. To this end, efforts include revamping product design and production methods, and increasing local procurement for pre-process items.

In the fiscal year ended March 31, 2014, positive effects including recovery in Europe and China and growth in the Americas helped us achieve a 22% increase in net sales in automotive applications and an operating income of 12 billion yen, putting us in the black for the first time in three years.

Our biggest focus in improving profitability is expanding sales in the highly profitable aftermarket applications. To strengthen our repair services for MRO (Maintenance, Repair, and Overhaul) business aimed at social infrastructure industries such as steel, mining, and paper, we are providing monitoring and technical analysis services for bearing operations, and technical classes for customers via mobile training units, and we are reinforcing our abilities throughout the supply chain.

Thanks to these measures, in the fiscal year ended March 31, 2014 the aftermarket applications enjoyed significant improvement, with net sales of 103.8 billion yen (up 16% over the previous fiscal year) and operating income of 17.7 billion yen (up 20% over the previous fiscal year).

Also crucial to improving profitability is expansion for the industrial machinery business. To expand sales in the



aftermarket, it is important above all to use original parts, and we will boost sales in growth sectors and step up business in China and ASEAN.

In the fiscal year ended March 31, 2014, factors including strong business for wind turbines in the Americas resulted in increases in both net sales and operating income in the industrial machinery business, with the latter showing particularly remarkable improvement at 120% over the previous fiscal year.

Progress in “Improving Asset Efficiency”

- **Besides striving for capital investment with high business efficiency, we are working to improve the inventory turnover ratio.**

“Improving Asset Efficiency” is crucial to corporate growth. Under “Revival 2014,” we are carrying out measures focused on capital investment and inventory.

We are totally revising our past policy on capital investment as we proceed with reduction measures based on keeping the investment amount within the allowance for depreciation. As well, we are striving to achieve efficient management that boosts productivity while making the most of less capital investment: we are doing this through measures that include responding to increasing world demand by raising the operational efficiency of existing facilities, shifting facilities from Japan to countries where production volume is expected to increase, revising facilities’ specifications, and reducing unit cost.



Product training session for customers

Interview with the Top Management



In the fiscal year ended March 31, 2014, inventory was 166.5 billion yen, a slight increase over the previous year on a monetary basis; however, this was due partly to exchange rate effects, and in fact we were able to decrease inventory volume. The inventory turnover ratio improved from 3.3 times in the fiscal year ended March 31, 2013 to 3.8 times in the fiscal year ended March 31, 2014. Our policy is to improve the inventory turnover ratio to 4 times.

Progress in “Better Management Framework”

- Working towards “on local site with local materials by local personnel”* by training human resources and strengthening organizational structure globally

First and foremost in “Better Management Framework” is working towards achieving “on local site with local materials by local personnel.”

The overseas production ratio in the fiscal year ended March 31, 2014 was 49%, a large increase over the 43% of two years previous. The target for the fiscal year ending March 31, 2015 is 50% or more. We have also been working on local procurement, with a local procurement ratio of 84% in the fiscal year ended March 31, 2014, up significantly over the 80% of two years previous. However, to benefit from the current low yen, we are urging customers to accept a change to different materials as we gradually do so in accordance with currency exchange rates.

We are also striving to strengthen organizational structure. To strengthen the CSR capabilities of worldwide NTN Group companies, in April 2014 we established the CSR Headquarters, which encompasses the former CSR Department and Legal Department, and Fair Trade Promoting Department. Also in April 2014, we strengthened internal control functions in various world regions by appointing an Internal Control Section in the General Managers’ offices of overseas subsidiaries. To better go on the offensive in the aftermarket business, we increased personnel in the Aftermarket Business Headquarters. We also strengthened the systems for direct visits to customers and technical services by establishing three branches (East Japan, Central Japan, West Japan) and new divisions in areas such as sales and engineering and production planning and management.

Furthermore, because of the necessity of developing global human resources who can implement our policy of “on local site with local materials by local personnel” in any country in the world, we established the Global Human Resource Development Department. This division will lead our efforts to train a diverse range of personnel who can convey techniques and skills from mother factories in Japan to worldwide production sites.

* “On local site with local materials by local personnel”: Establish a system in which NTN’s local employees manage business using locally sourced equipment and materials.

Improving asset efficiency

Capital expenditures and depreciation

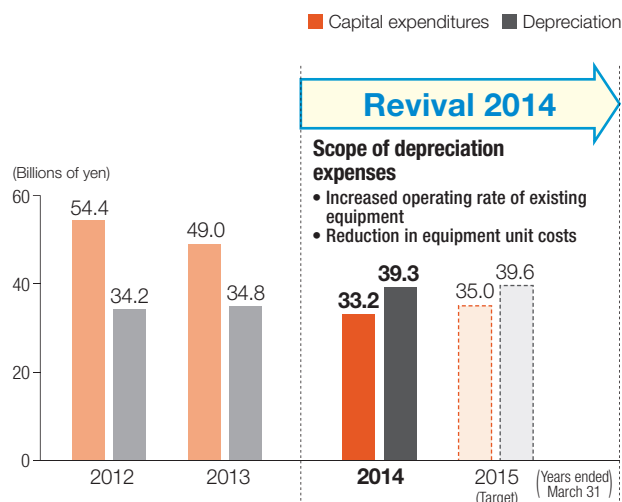

Inventories and inventory turnover ratio

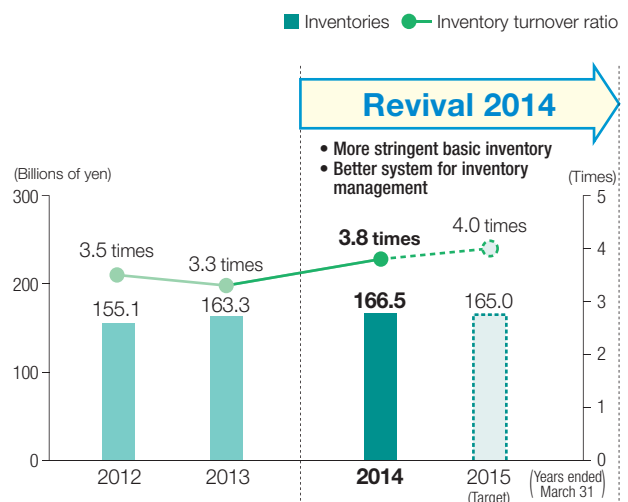

● Accelerating development of high-value-added module and system products

We are focusing on accelerating new product development. For a manufacturer like NTN, the heart of the management framework is the development of highly competitive products for customers around the world. Under “Revival 2014,” we are stepping up efforts in the areas of module and system products, composite material products, and EV system products.

Key among these is the mass-production of module and system products. By moving from individual components to module and system products, we are not only making products smaller and lighter but also reducing the number of parts and the amount of assembly labor. This also creates barriers to companies infringing on our intellectual property rights.

NTN has over the years made individual components such as bearings and constant-velocity joints, along the way adding peripheral components to its product lineup as it progresses to products such as bearing units and hub bearings. Today, we are focusing on module products with new part combinations, such as bearings with sensors and IC tags. In doing so, we have earned a superb reputation for products such as the “Ball Screw Drive Module for Electric Hydraulic Brake” (released in April 2013), and “Mechanical Clutch Unit (MCU) for Next-generation Steering” (released in November 2013).

We are also working on new products and technologies that support the future of NTN; for example, our Condition Monitoring System (CMS) for wind turbines, the “Wind Doctor™,” which combines control technologies and bearings, and In-wheel Motor Systems for compact EVs.



Ball Screw Drive Module for Electric Hydraulic Brake

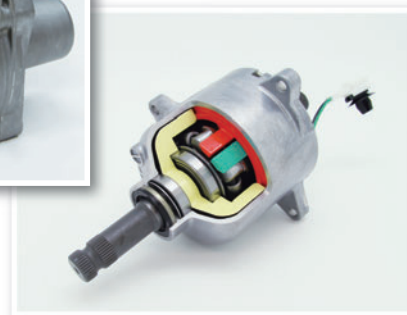

Mechanical Clutch Unit (MCU) for Next-generation Steering*

* Photos are cross-sectional models of products.

Q7 Tell us about your thoughts for future CSR plans and measures.

A We will work towards the realization of a sustainable society by meeting the public’s expectations in economic, environmental, and social aspects.

NTN works towards the realization of a sustainable society by meeting the public’s expectations to make CSR efforts, such as boosting economic value, reducing environmental impact, and contributing to communities, part of the company’s business activities.

For example, we strive to achieve thorough corporate governance, strengthen compliance, improve risk management, and reduce environmental impact.

In April 2014, we revised our organizational structure through the establishment of the CSR Headquarters. To continue meeting the expectations of our customers, suppliers, employees, shareholders, local citizens, and other stakeholders, the entire NTN Group will take on all necessary CSR challenges. (See page 42 for details.)

Better Management Framework (on local site with local materials by local personnel)

Overseas production ratio

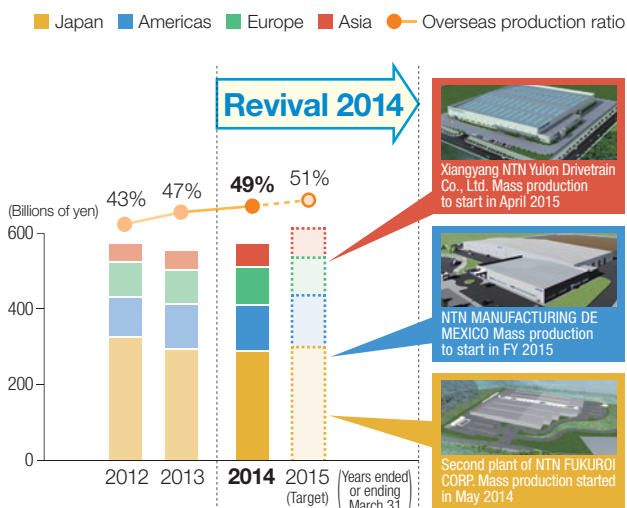

Local procurement ratio

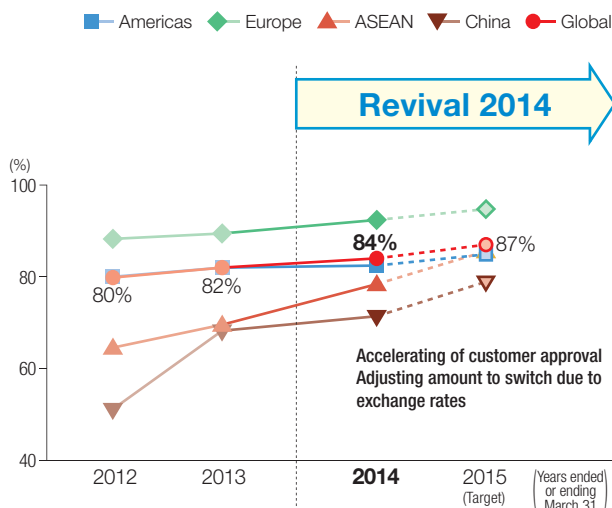

Medium-term Management Plan “Revival 2014” – Progress and Future

With the aim of “reforming business structure to generate profit,” the NTN Group announced its “Revival 2014” two-year medium-term management plan in February 2013. All divisions of the group are enacting measurements steadily based on this plan to achieve targets for the fiscal year ending March 31, 2015. This feature reports on progress thus far on “Revival 2014” and at NTN’s outlook for future growth.

Economic Effect against Operating Income of Main Policies

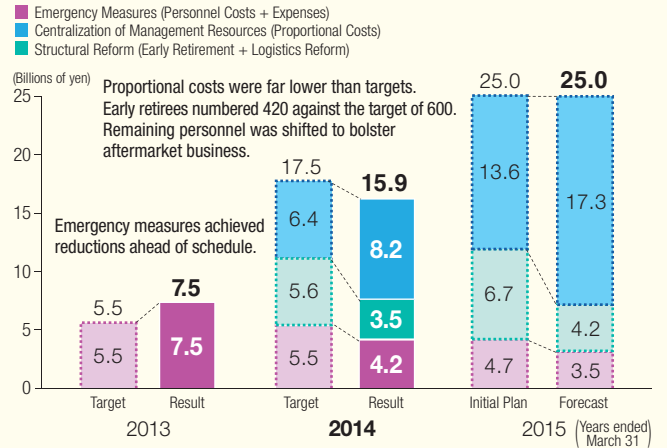

1 Emergency Measures

Short-Term Measures to Generate Profit

- ① Reduce personnel costs and fixed costs
- ② Limit capital expenditure
- ③ Reduce inventories

3 Structural Reform

Mid-Term Business Structural Reform

- ① Reforms to personnel costs
- ② Acceleration of overseas production
- ③ Selection of business

2 Centralization of Management Resources

Centralization on Priority Fields

- ① Greater profits in Automotive Business
- ② Sales expansion for Aftermarket
- ③ Strengthening Industrial Machinery Business globally

4 Expansion of New Products and New Business

Towards Further Growth

- ① Strengthening development of module products and system products
- ② Full operation of the EV system products business
- ③ Development of composite material products and market deployment

Medium-term Management Plan “Revival 2014”
(Announced February 2013)
Applicable Period
April 2013 to March 2015
(2 year period)

Basic Policy
Reform Business Structure to Generate Profit

1 Emergency Measures

Short-Term Measures to Generate Profit

Under “Revival 2014,” emergency measures aimed at generating profit were begun in the second half of 2012 as short-term measures. The main policies are reduction of personnel costs, reduction of fixed costs, reduction of inventories, limitation of capital expenditure, and abolishment and sale of assets.

(Billions of yen)

Main Policies	Fiscal year ended March 31, 2013		“Revival 2014” (2 Years) Plan
	Plan	Result	
Reduce personnel costs	2.0	3.0	28
Reduce fixed costs	3.5	4.5	74
Limit capital expenditure	48.0	49.0	Limit to 51 billion yen, under depreciation costs over two years
Reduce inventories	157.0	163.3* (154.1)	Reduce up to 145 billion yen in two years
Abolish, sell assets	10.0	121	—

* Excluded exchange rates

1 Reduce personnel costs and fixed costs

To reduce personnel costs, we reduced salaries and bonuses, mainly at NTN and existing group companies. We also offered early retirement options to 600 employees, and 420 applied for this. Remaining employees were mostly diverted to the aftermarket business that the company focuses on. These measures resulted in personnel cost reductions of approximately 3 billion yen in the fiscal year ended March 31, 2013.

To reduce fixed costs, we looked at all divisions, mainly at NTN and existing group companies, analyzing expenses that contribute directly to profits and promoted to cut these. As a result, we were able to reduce fixed costs by approximately 4.5 billion yen, above our plan for the fiscal year ended March 31, 2013.

2 Limit capital expenditure

Under “Revival 2014”, we reviewed all past capital expenditures and decided on a policy of keeping investments to less than the value of depreciation. In the fiscal year ended March 31, 2013, as a result of measures that included utilizing existing equipment, moving equipment in Japan to overseas sites, increasing local procurement of equipment, and developing inexpensive equipment, capital expenditures were 49 billion yen, within our plan excluding exchange-rate effects. The result for the fiscal year ended March 31, 2014 was even lower, 33.2 billion yen, and less than depreciation.

While continuing to meet increasing demand around the world, we are doing everything possible to expand business while enacting measures that minimize investment amounts.

3 Reduce inventories

To reduce inventories, we reduced inventory of products and products in process through company-wide projects and the use of IT systems. Inventory was 163.3 billion yen in the fiscal

year ended March 31, 2013, which included exchange-rate effects, and on a volume base it was actually 154.1 billion yen, 2.9 billion yen below our plan of 157 billion yen. In the fiscal year ended March 31, 2014, inventory was up slightly to 166.5 billion yen, but this includes exchange-rate effects and on a volume base it represents a further decrease. The inventory turnover ratio increased to 3.8 times, and we will continue to strive to reduce inventory as well as boost the turnover ratio to 4 times in maximizing capital efficiency.

We are also working to reduce capital through measures such as booking impairment losses on unnecessary equipment and buildings, and incurring extraordinary losses from soil purification by selling the former site of TAKARAZUKA WORKS.

2 Centralization of Management Resources

Centralization on Priority Fields

The second main policy of “Revival 2014” is centralization of management resources. We are proceeding with measures in three areas that we have decided require crucial influxes of management resources: greater profits in the automotive business, sales expansion for the aftermarket, and strengthening the industrial machinery business globally.

1 Greater profits in Automotive Business

Reviewing design and manufacturing methods

To increase profits in products for the automotive business, we are reviewing our design and manufacturing methods. We are thoroughly reducing costs through efforts such as introducing technologies to standardize parts and unify product models, and using reasonably priced materials. **Figure 1**

In product development, we are working towards greater profit in the automotive business through early market introduction of high-value-added products. These include the EBW Drive Shaft (released in May 2014), in which the inboard outer ring, which was previously specifically designed and manufactured for each model, is standardized, and in which the cup section and stem (shaft) section are welded using electron beam welding; and the Press Connect Spline Hub Joint (released May 2012), which allows for lighter weight and eliminates backlash in fittings through the use of a proprietary fitting method.

Expand local procurement of steel and pre-process parts

To increase profits in the automotive market, we are working to procure more steel and pre-process parts locally. By using locally procured materials and accelerating the local integrated production of parts from pre-processes, we can reduce shipping costs, avoid exchange-rate risks, reduce manufacturing lead-time, and cut material costs.

Besides using more inexpensive, high-quality steel in countries like China and Korea, we are proceeding with cost reductions made possible by free trade agreements. For example, by importing steel to Thailand from Korea, and shipping products made in Thailand to around the world, we are reducing customs duties.

For forging and turning, we are accelerating the development of local manufacturers to take up pre-process production, thus expanding local procurement of pre-process parts. We currently have about 300 overseas suppliers (conducting forging and turning, and making parts), a number that represents a 10-fold increase over 10 years.

We will continue to strengthen partnerships with local manufacturers in order to manufacture more pre-process parts locally through joint business. (Our initial target for the global local procurement rate for the fiscal year ending March 31, 2015 was 90%; however, we are now aiming for an 87% rate due partly to the benefits of the current weak yen.)

2 Sales expansion for Aftermarket

Establishment of the Aftermarket Business Headquarters

In October 2013, we established the Aftermarket Business Headquarters to expand sales in the aftermarket. Besides increasing the number of aftermarket business personnel, we established three sales offices (East Japan, West Japan, Central Japan), and new departments including Sales Engineering Planning and Production Planning. We are also expanding and reorganizing our sales network, and we will expand in flourishing demand markets such as Indonesia, Russia, Eastern Europe, and China.

To strengthen our system of provision, we began operations at the Kuwana-Inabe Plant in April 2013 to specialize in individual products and multi-product small-lot production for the aftermarket business. This will allow us to more quickly

and flexibly satisfy customer needs and thus expand sales. Regarding distribution, we concentrated our best-selling products at aftermarket stock centers in Japan. This allows us to better provide these products to all regions and ensure that we do not run out of them, thus ensuring we take advantage of all opportunities for sales.

Expand the auto parts business

The auto parts business is a key target of the aftermarket business. In this field, we are focused on automotive bearings and kit sales that combine peripheral components. We have a product lineup that gives superior convenience to customers with products such as axle kits and fan-belt kits, and it represents our shift from general purpose items to high-quality, high-value-added products and thus greater profitability. Utilizing our years of experience in combining components, we are providing kits for engine and wheel applications of passenger cars and large trucks, constantly expanding our product lineup to meet new application needs, as well as moving our marketing activities beyond just the conventional markets of Europe and the Americas to encompass Asia and other regions. **Figure 2**

Utilizing our dedicated auto parts catalogue, we are proposing combinations by unit in an easy-to-understand manner, thus contributing to boosting our share of the world market for the aftermarket.

Expand the MRO business

Another key target is the MRO* business, which covers bulk contracts for equipment repair for customers in industrial fields like steel, paper, port facilities, and mining. We strive to offer our users and distributors technical diagnoses, training, and other guidance by providing timely maintenance proposals with equipment diagnostic technologies such as monitoring and data analysis based on an NTN database of when our industrial machinery customers need to change their bearings,

Centralization of Management Resources —Centralization on Priority Fields—

Figure 1 Example of standardized parts (drive shaft)

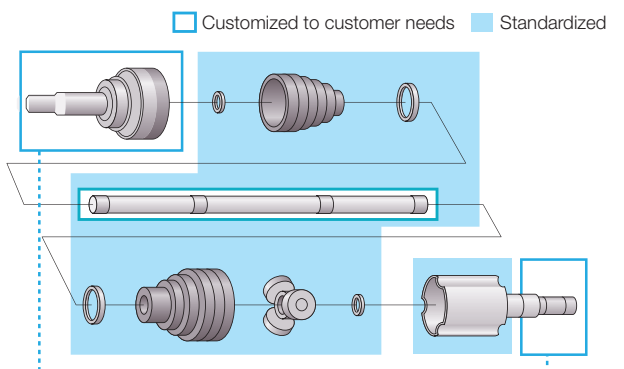

Depending on parts differences between models, such as shaft length and shape, and on the degree of necessity, it is possible to combine parts with a unified design

Figure 2 Auto parts kit

Providing a kit that combines automotive bearings and peripheral components



Figure 3 Technical service unit

Visits customer sites and provides services that lead to new orders



and utilization of technical service units that visit our customers with bearings and maintenance tools. **Figure 3**

In April 2013, our mobile training units embarked on tours of customer sites, providing technical services and support for repair and maintenance using maintenance tools, and in the process helped boost the brand image of NTN.

* MRO: Maintenance, Repair, and Overhaul

3 Strengthening Industrial Machinery Business globally

Expand sales in growth industries

In the industrial machinery business, a key effort involves expanding sales in growth industries. We are conducting marketing activities in earnest with a focus on sectors that are expected to continue growing worldwide, including aerospace, rolling stock, wind turbines, machine tools, and agricultural machinery. **Figure 4**

In aerospace, in October 2012 we were recognized as an official supplier of Pratt & Whitney to mass-produce bearings for the PurePower® family of jet engines, and mass-production and delivery is scheduled to start in June 2014. In June 2013, we received our first order to mass-produce bearings for the Rolls-Royce Trent XWB new jet engine. This made us the first and only bearing manufacturer in Japan to be certified to supply products to the world's four major jet engine manufacturers.

In the growing worldwide market for wind power systems, we plan to further boost marketing of new products, such as bearings for wind turbines, and our Condition Monitoring System (CMS) for wind turbines, the "Wind Doctor™," a proprietary system developed by NTN.

Expand sales in low-share regions

Another key effort in the industrial machinery business is to expand sales in regions where we still have a low market share. We are particularly strengthening business in target sectors

such as wind turbines, construction machinery, machine tools, and rolling stock in China and ASEAN. In the fiscal year ended March 31, 2014, we took large-scale orders for contacts in rolling stock, including high-speed railways and light rapid transit (LRT), and we delivered prototypes in anticipation of new orders. In machine tools and agricultural machinery as well, sales were gradually expanding as we took new orders in China.

In China and ASEAN, quality standards are improving for local products and customers are demanding bearings with high added value, and this is prompting us to step up marketing to local manufacturers. Making use of the NTN China Technical Center in Shanghai, we are matching design and development to the demands of local customers so that we can shorten the time it takes until we receive product orders.

3 Structural Reform

Mid-Term Business Structural Reform

With the aim of building a strong corporate structure, we are reforming our business structure with an eye on the medium term under "Revival 2014". The three pillars of these efforts are reforms to personnel costs, which accompany expansion of overseas production; acceleration of overseas production, which is carried out medium to long term; and selection of business, which includes reform of distribution processes and withdrawal from a part of business in precision equipment.

1 Reforms to personnel costs

Under strategies to expand overseas production, we are shifting the numbers of personnel between different regions and reforming the personnel cost structure in order to reduce personnel costs. As a result of increasing the number of personnel overseas, the percentage of NTN employees

Figure 4 Sectors and strategies in the industrial machinery business

Rolling stock

- Expansion of manufacturing in Japan and Europe
- High-speed technologies help increase market share



Construction machinery

- Four manufacturing bases* expands range of sales to local manufacturers

* In Japan, the Americas, Europe, and Asia



Machine tools

- Using high-speed and environmental technologies to secure new orders



Aerospace

- For world's four major jet engine manufacturers
- Increasing production capacity in Japan and Europe



Wind turbines

- Manufacturing in Japan, China, and Europe
- Marketing the "Wind Doctor™" around the world



Robots, gear boxes

- Expansion of bearings with sensors and composite material products



Agricultural machinery

- Four manufacturing bases, more applications for constant-velocity joints

For New Technology Network
NTN®

overseas at the end of fiscal year ended March 31, 2014 was approximately 64%, with the Asian region adding about 500 people in a year. Overseas employees will continue to account for an increasing percentage of NTN as a whole.

And based on our philosophy of “on local site with local materials by local personnel,” we will hire more local human resources and increase and train local managers who will act as key personnel.

2 Acceleration of overseas production

We are accelerating the move of our production to demand regions so as to establish a production system that is unaffected by exchange rates. To make the most of existing equipment, as a rule we produce local products at local sites, and we are responding to new demand by moving manufacturing equipment from Japan to overseas bases. In the fiscal year ended March 31, 2014, the local production rate increased by 2% to 49% year on year, and we will continue to increase this with a medium- and long-term view and achieve greater profits in the automotive business.

As for items currently mass produced in Japan, to spread risk and boost productivity through the latest Monozukuri, we are moving production to newly established subsidiary plants. At NTN’s own plants, we are boosting profitability through efforts including focusing on the manufacture of high-value-added products such as module products and system products.

3 Selection of business

Under our selection of business efforts, in April 2014 we established NTN LOGISTICS CO., LTD., a subsidiary that integrates production logistics and sales logistics functions. Logistics costs will be lowered through various efforts: more

efficient transportation through centralized management of finished products, semi-finished products, and procured parts; elimination and consolidation of logistics centers; reviews and improvements of packaging specifications; and elimination various aspects of wasted work by visualization of logistics costs. Furthermore, we are striving to provide services that thoroughly satisfy customers, including improving logistics quality and implementing safety and environmental measures, and we are striving to contribute to society.

To raise the profitability of the group as a whole, we are pulling out of some precision equipment products in the industrial machinery business, and we are shifting employees in these categories to development and marketing functions in new product and business areas as we strive to restructure our business.

4 Expansion of New Products and New Business

Towards Further Growth

The fourth main part of “Revival 2014” is the expansion of new products and new business in order to achieve further growth. Here, we are carrying out a range of measures based on three pillars: strengthening development of module products and system products, full operation of the EV system products business, and development of composite material products and market deployment.

1 Strengthening development of module products and system products

NTN is evolving towards what we call module products and system products. The module products we develop are new

Expansion of New Products and New Business —For Further Growth—

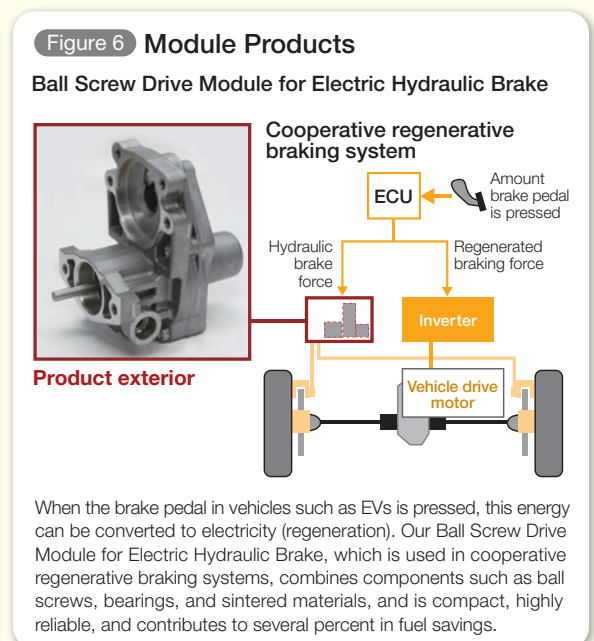
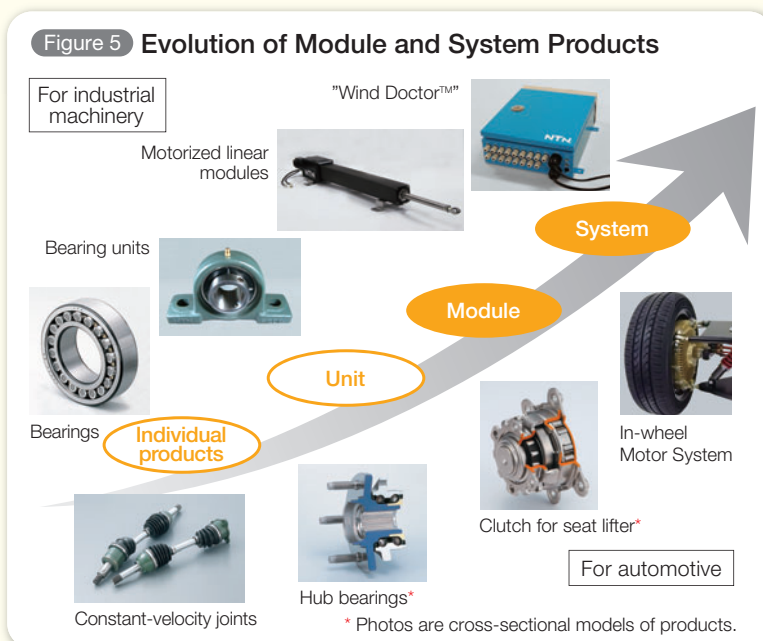

combinations of our years of experience in individual products such as bearings and constant-velocity joints and peripheral components, along with products including sensors, actuators and other components. System products represent an advanced integration of mechatronics technologies and control technologies. **Figure 5**

Not only do these module products and system products help reduce the number of components and help make finished products smaller and lighter; they also reduce the amount of assembly man-hours by customers and give products added value. As exemplified by products like our Ball Screw Drive Module for Electric Hydraulic Brake (released in April 2013), we will continue to step up development of module products through new combinations of components. **Figure 6**

We are also focusing on developing system products, like our Condition Monitoring System (CMS), the "Wind Doctor™," for wind turbines (released June 2012), that integrate our proprietary advanced mechatronics technologies such as sensor technologies and control technologies. This will boost profitability and lead to the creation of new services and solutions that help us achieve further growth.

2 Full operation of the EV system products business

NTN is creating future technologies by focusing on research and development in the EV field. We have an increasing number of demonstration businesses underway in which our next-generation EV system products developed with proprietary technologies are being used in actual vehicles and by commuters in tests on public roads. Starting in October 2011, we teamed up with the municipal government of Iwata City in Shizuoka for a social demonstration test, and in June 2013 in Annecy City, France,

we began the first demonstration test in the world of a microcompact EV equipped with the in-wheel motor as a registered vehicle conducted on public roads. **Figure 7**

In Japan, in the fiscal year ended March 31, 2014, microcompact EVs in Shizuoka Prefecture using NTN's In-wheel Motor System became the first such compact cars registered in Japan and underwent testing on public roads. In Ise City, Mie Prefecture, the In-wheel Motor System was used in the first microcompact mobility car in Japan. As well, NTN's technology is used in converted EVs being used as official city vehicles for the municipal government of Kuwana City, Mie Prefecture.

Through such demonstration businesses, we are moving more quickly towards the practical application of our EV system products.

3 Development of composite material products and market deployment

NTN has built up a range of material technologies, exemplified by sintered bearings using metal powder, and plastic bearings using high-performance materials. We are now expanding our business into new spheres with new and advanced functional materials made possible by combining these existing proprietary technologies with the molding and manufacturing technologies of NIPPON KAGAKU YAKIN Co., Ltd., which joined the NTN Group in 2011. Amorphous core is one of our flagship composite material products, and it is a focus of attention for its use in reactors in the rapidly expanding EV and hybrid market, and as MRI choke coils in increasingly highly functional medical equipment. **Figure 8**

We are moving ahead in developing numerous composite material products that utilize the NTN Group's range of material technologies, taking these technologies to market and thus further strengthening our management framework.

Figure 7 EV System Products

In-wheel Motor System



The In-wheel Motor System incorporates an In-wheel Motor and a control system that is linked to sensor information. Incorporating a motor into each wheel makes the car's interior more spacious, and makes possible a car capable of "pivot turn" and "lateral move".



Demonstration business in France

Figure 8 Composite Material Products

Plastic materials (BEAREE)



Low Torque Seal Ring



Sliding Bearing Unit for High Load Applications

Sintered Metal (BEARPHITE)



Corrosion Resistance BEARPHITE



Hybrid BEARPHITE HP

Magnetic Material (NIKAMET)



Injection Bond Magnet

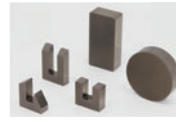

High Performance Magnetic Core

Amorphous Core



For EVs and HEVs



Used in converters for EVs



For medical equipment

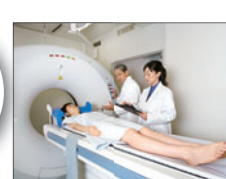

Used in MRI choke coils

The amorphous core is made through the injection molding of magnetic material comprising a mixture of amorphous powder and resin. Its applications include EVs and HEVs, and choke coils in medical equipment.

▼ Net Sales in Each Business Application as Percentage of Total Sales

Aftermarket Applications

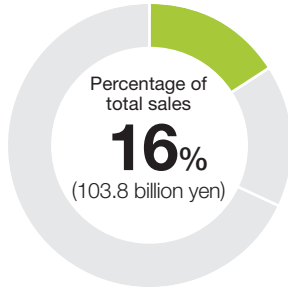

This business covers aftermarket bearing sales for general machinery through distributors, the aftermarkets for mining, paper, and steel machinery, as well as the aftermarket for automotive repair parts (auto parts). We provide increasingly more bearings of all types to customers around the world.

Net Sales and Operating Income for the Aftermarket

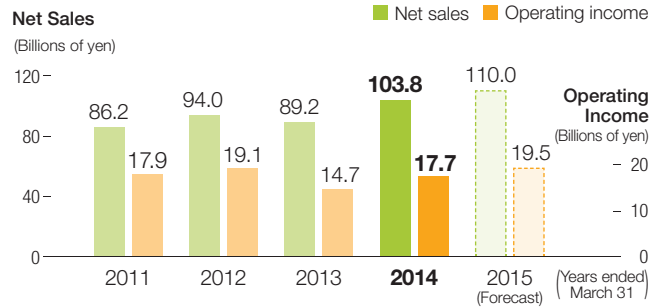

Industrial Machinery Applications

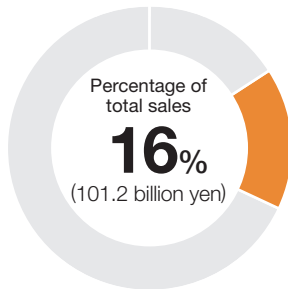

This business covers a range of industrial machinery sectors including construction machinery, agricultural machinery, aerospace, office equipment, wind turbines, machine tools, and rolling stock. We are working to expand sales by integrating new technologies into all sizes of bearings.

Net Sales and Operating Income for the Industrial Machinery

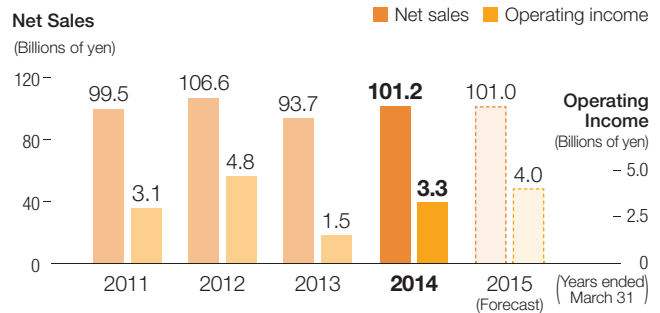

Automotive Applications

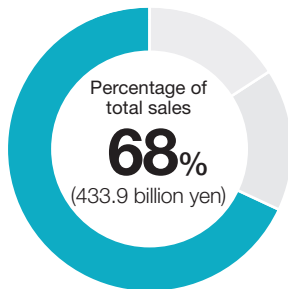

This business covers the automotive and automotive-related market. With the main products of hub bearings, constant-velocity joints, and needle roller bearings, NTN provides the world's automotive and automotive-related companies with new technologies and products.

Net Sales and Operating Income in Automotive Applications

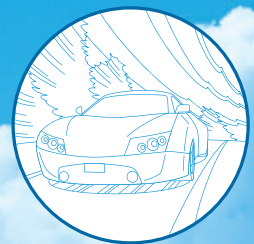
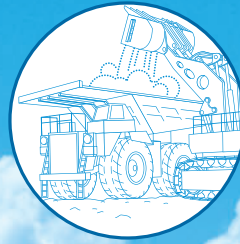
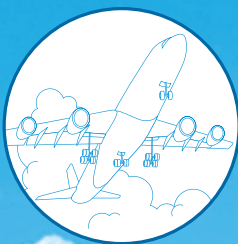
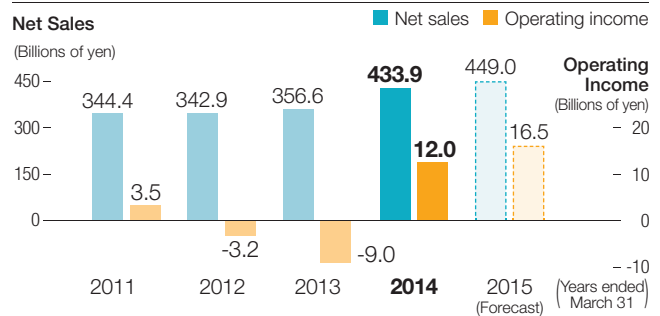

Reference: Net Sales by Region

Japan

Percentage of total sales

28%

(Billions of yen)

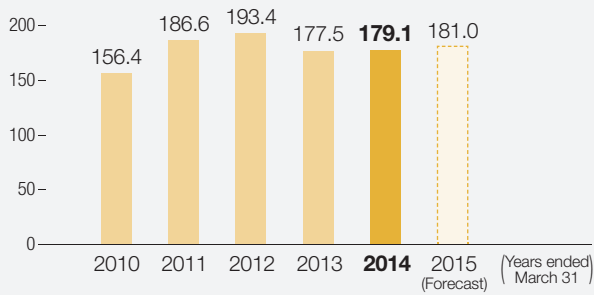

In the aftermarket applications, sales were down due to a drop in the aftermarket for industrial machinery. In industrial machinery as well, due to a drop in customer demand in China and other Asian countries, sales were down in construction machinery and other sectors. In the automotive applications, despite a drop following the end of the Japanese government's eco-car subsidy, sales were up overall thanks to factors including increased customer demand.

Europe

Percentage of total sales

26%

(Billions of yen)

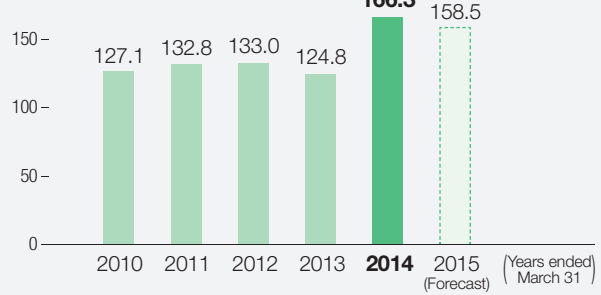

In the aftermarket applications, sales were up on demand recovery from customers in the automotive aftermarket sector. Sales in industrial machinery applications were little changed from the previous year, although the automotive applications saw a rise in sales thanks to a recovery in customer demand.

Americas

Percentage of total sales

27%

(Billions of yen)

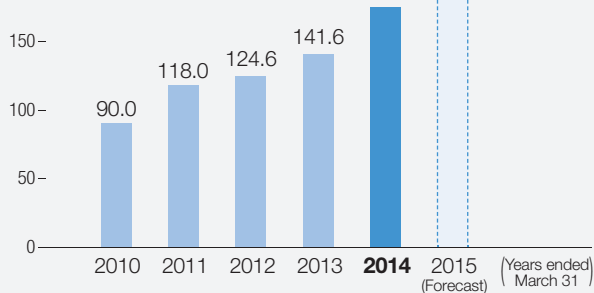

Sales were up in the aftermarket applications thanks to a recovery in customer demand in the automotive aftermarket sector. Industrial machinery saw a drop, particularly in sectors such as construction machinery. In the automotive applications, however, sales were up overall thanks to factors including increased customer demand.

Asia and Others

Percentage of total sales

19%

(Billions of yen)

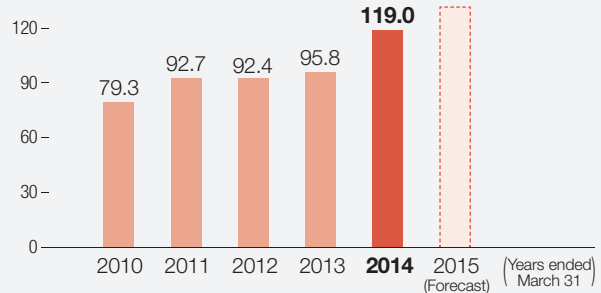

Aftermarket sales were down on decreases in industrial machinery aftermarket products. In the industrial machinery applications, sales were up in China on the strength of increased customer demand for wind turbines but were down in other parts of Asia as customer demand decreased. In the automotive applications, sales were down due to slower customer demand in Asian countries, although China saw a sales increase thanks to a recovery in business to Japanese manufacturers in that country and mass production of new projects.

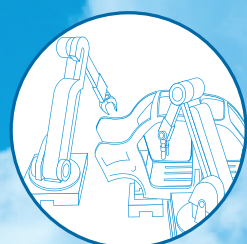
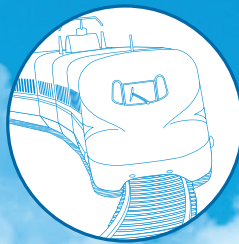
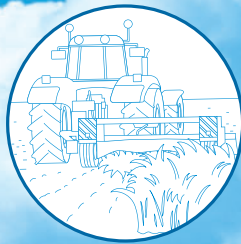
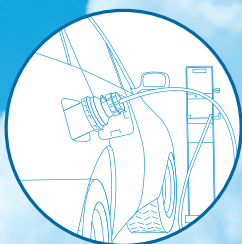

Aftermarket Applications

We are Utilizing Our Engineering Capabilities to Expand the Aftermarket Applications.

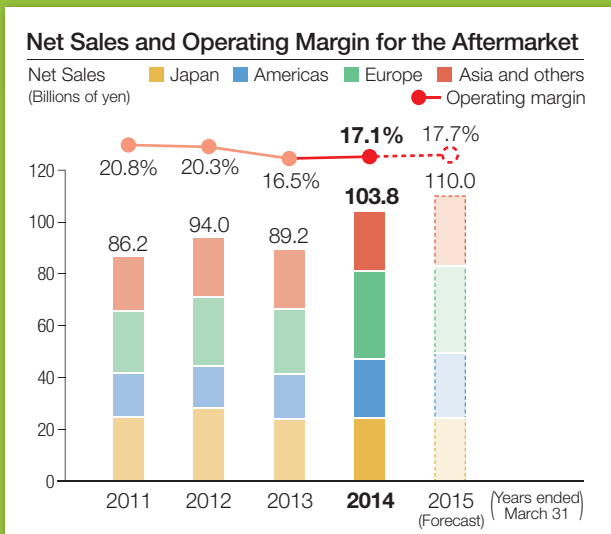

Results in the Fiscal Year Ended March 31, 2014

Net sales in the aftermarket applications were 103.8 billion yen, up 14.6 billion yen (16.4%) over the previous fiscal year.

Amidst slumping demand worldwide in industrial machinery, sales were down in the aftermarket for industrial machinery, but this was offset by strong sales in auto parts for the automotive aftermarket sector in the Americas, Europe, and other regions.

Operating income was up 3 billion yen (20.4%) to 17.7 billion yen thanks partly to positive exchange rate effects.

Overview of the Fiscal Year Ending March 31, 2015

In the fiscal year ending March 31, 2015, we forecast an increase in Asian countries for both industrial machinery and automotive, which we will take advantage of by stepping up our technical services via mobile training units to increase MRO (Maintenance, Repair, and Overhaul) orders and by increasing the number of new distributors for auto parts. We are introducing new products for automotive in the Americas, where we will work to boost sales through collaboration among our three North American subsidiaries.

Medium- and Long-Term Strategies

We are looking to expand MRO for industrial machinery, not just in the focus markets of Europe and the Americas but also in Russia, Eastern Europe, Turkey, Africa, and other regions. We still expect further growth in China, ASEAN, India, and other regions, and in Japan we will tap new demand for MRO through methods including more direct visits to customers in target segments. In the automotive applications as well, we will step up sales activities in markets where we forecast large growth in demand for car repair parts; that is, regions where car ownership is dramatically increasing, including China, ASEAN, India, Russia, Eastern Europe, and South America.

We will also continue boosting our engineering capabilities, such as through the use of mobile training units conducting technical services and on-site training courses. To boost supply chain capabilities, we will commit to delivery due dates and boost inventory of top-selling products, and we will expand the product lineup through efforts including expansion of production at a dedicated plant, establishment of aftermarket stock centers and maintenance of a global inventory replenishment system. Under a strong organizational structure for not just sales but also the production and engineering divisions as well, we will focus on these various efforts as we work to expand our aftermarket business.



Fukumatsu Kometani
Executive Director

Main Product Lineups for the Aftermarket Applications

* Photos are cross-sectional models of products.

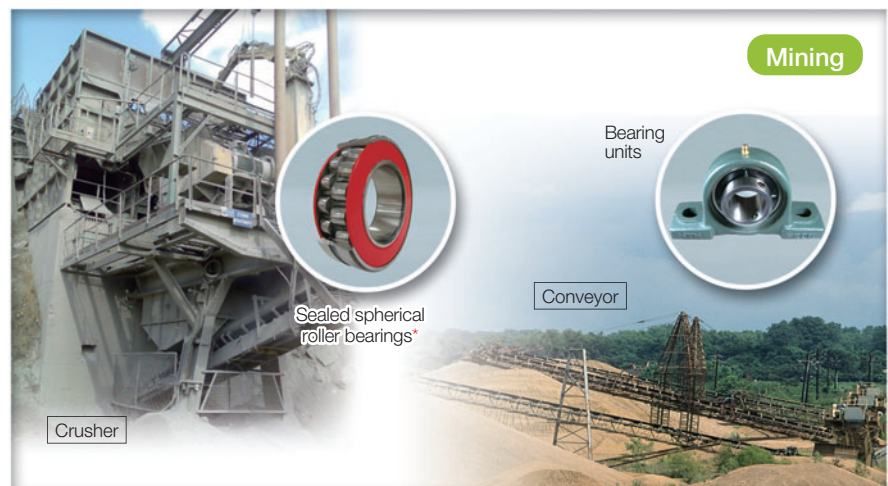

At a Glance

Q Topics

NTN Develops Handy Type Failure Detection Device

Using its years of experience in bearing diagnostic technology, NTN has developed an industry first: a device with outstanding portability for measuring and analyzing the vibration of bearings. The device utilizes a smartphone to send vibration data via the internet to a server for calculation and analysis. The input and output is also displayed on the smartphone, which makes for an extremely compact and portable vibration measurement system.

The device boasts a range of functions, such as the ability to upgrade to the latest usage environment through integrated processing and control by data calculation and analysis software; determine damaged parts of the bearings when there is a problem; and remotely monitor the state of the equipment. This product will go on sale in Japan sometime in 2014.

We will offer improved diagnostic and analysis devices and continue to expand our aftermarket business by strengthening our technical services.



Handy Type Failure Detection Device

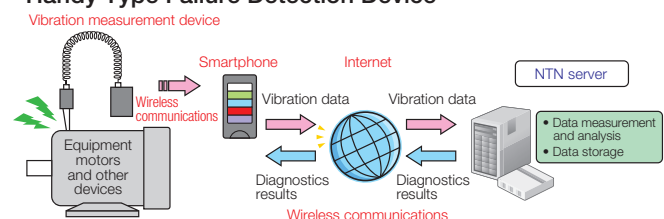

Industrial Machinery Applications

We are Focusing on Expanding Sales in the World's Growth Sectors.

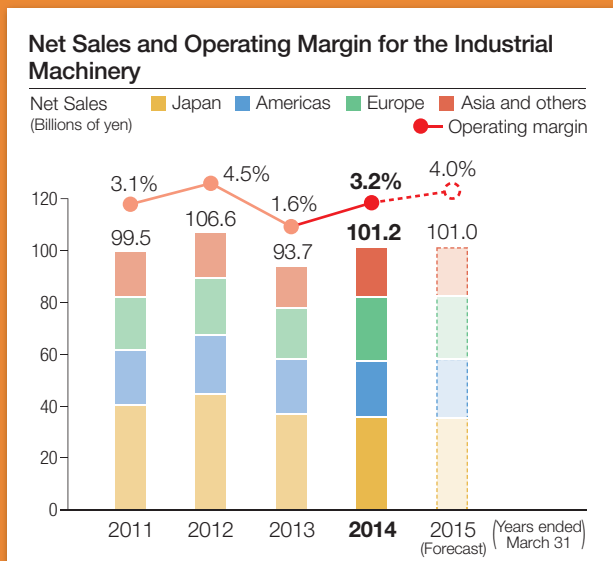

Results in the Fiscal Year Ended March 31, 2014

Net sales in the industrial machinery market were 101.2 billion yen, up 7.5 billion yen (7.9%) over the previous fiscal year.

Amidst slumping demand in construction machinery worldwide, in China this sector recovered and demand was up in the wind turbine and rolling stock sectors as well. Strong sales were recorded for rolling stock and aircraft in Japan and Europe, and for wind turbines in the Americas.

Operating income was 3.3 billion yen, up 1.8 billion yen (113.8%) over the previous fiscal year due to a decrease in fixed costs such as labor and favorable effects of exchange rates.

Overview of the Fiscal Year Ending March 31, 2015

We are being cautious overall in our predictions for the fiscal year ending March 31, 2015. This is due to a drop in demand when compared with the rush in demand for construction machinery in the previous year in the high-volume market of Japan, an expected delay in demand recovery in Europe due to instabilities including the situation in the Ukraine, and decreased demand in North America for agricultural machinery. At the same time, we foresee new orders in machine tools, strong sales in aircraft, and a rise in products for robotics.

Medium- and Long-Term Strategies

Our global business focus will continue to be on expanding sales in growth industries. Against a background of increasing population, energy supply issues, and economic development in newly emerging countries, we will step up technological development in expected growth markets such as agricultural machinery, wind turbines, machine tools, construction machinery, rolling stock, aircraft, and robots. As well, by expanding sales to local manufacturers demanding ever-higher quality, and strengthening business in China and ASEAN regions by maximizing the NTN China Technical Center, we are looking to expand sales in regions where our market share is still low.

Regarding product strategy, we are expanding the lineup of our ULTAGE Series, which boasts the world's highest load capacity and high-speed rotational performance for construction machinery, wind turbines, gear boxes, and hydraulic equipment, as well as a wide range of other general industrial machinery and aftermarket sectors. We are working to shift further from individual components to system products such as our Condition Monitoring System (CMS) for wind turbines. And we are working behind the scenes to better satisfy the needs of a range of customers by offering them an even higher level of QCDD (quality, cost, delivery, and development).

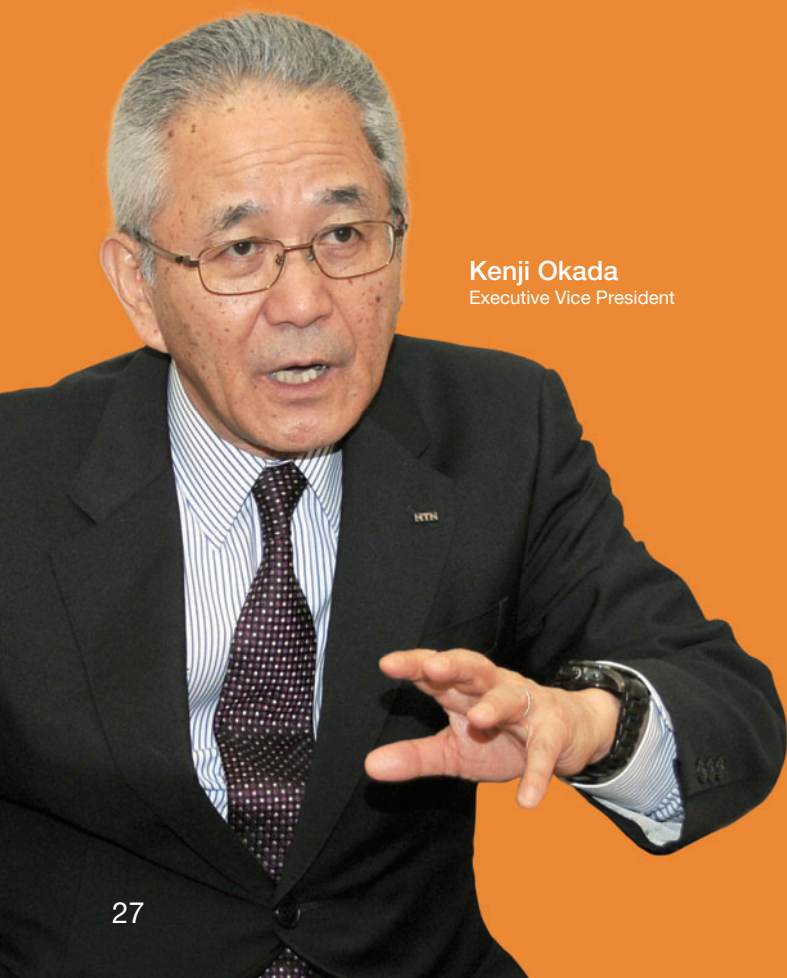

Kenji Okada
Executive Vice President

* Photos are cross-sectional models of products.

IC Tag Integrated Bearing

Condition Monitoring System (CMS) for wind turbines: the "Wind Doctor"TM

Construction machinery bearings
At work in resource mining and civil engineering

Agricultural machinery bearings
Contributing to food demand with high quality products

Gearbox bearings
Supporting industrial machinery robots

Aerospace bearings
At work in jet engines around the world

Office equipment bearings
Supporting smooth operation in copiers and multifunctional printers

Wind turbine bearings
Meeting growing demand in renewable energy and other areas

Machine tool bearings
High-precision support for high-speed-rotation

Rolling stock bearings
Providing safety for the world's high-speed railways

Hydrodynamic bearings
Used for HDDs and thin fan motors

Medical equipment bearings
Used in CT scanners and artificial hearts

Main Product Lineups for the Industrial Machinery Market

Bearing Technical Calculation System for Machine Tool Spindles (Image)

Customer → Send by e-mail → NTN
NTN → Receive by e-mail → Customer
Available 24 hours a day, 365 day a year

Motorized Linear Module for Tracking System for Solar Heat/Solar Light Power Generation

At a Glance

Q Topics

NTN Receives the 2013 "CHO" MONODZUKURI Innovative Parts and Components Award, Nippon Brand Award

For its Parallel Link High Speed Angle Control Equipment, a compact angle positioning device that allows high-speed, high-precision positioning over two-degrees of freedom and a wide range of moving angles, NTN received the Nippon Brand Award at the 2013 Cho Monodzukuri Innovative Parts and Components Awards sponsored by the Nikkan Kogyo Shimbun, Ltd.

The awards panel chose the NTN product for a number of reasons. A proprietary parallel link mechanism* consisting of two spherical links ensures a compact design and a wide range of movement, and the newly developed drive mechanism allows coordinated control of the angles of each of the stationary arms for high-speed positioning. The product allows high-speed application and application from various angles of substances such as grease and adhesive, which means high-speed processing of complex shapes. A special teaching console supports superior operability. The product is expected to contribute to more advanced automation and robotics technologies in production equipment.

* Mechanism comprising of three sets of similar link systems between the moving and stationary link hubs. Each link system consists of a rotating L-shaped arm attached to the outer circumference of the moving and stationary link hubs, and a rotatable connected intermediate link connecting the axis of rotation of the end of each hub in a single location.

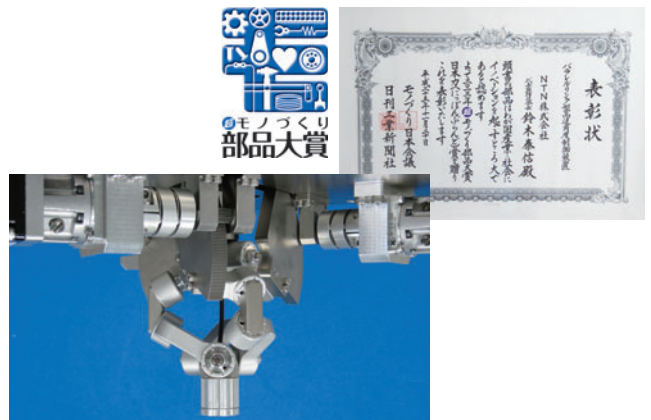

Automotive Applications

We Have Successfully Tackled the Challenge of Improving Profitability.

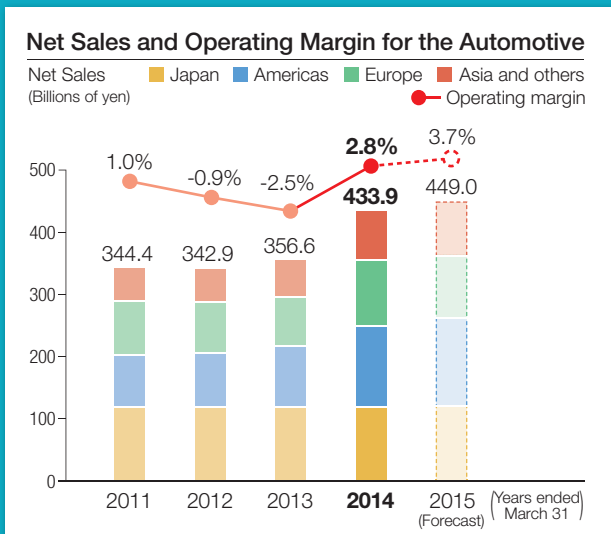

Yoshinori Terasaka
Managing Director

Results in the Fiscal Year Ended March 31, 2014

Net sales in the automotive applications were 433.9 billion yen, up 77.3 billion yen (21.7%) over the previous fiscal year.

The increase in car production around the world boosted customer demand in the Americas and Europe and pushed up sales. In China, there was a major recovery in customer demand particularly among Japanese manufacturers, while demand was up in Japan as well.

Operating income was 12 billion yen (compared to an operating loss of 9 billion the previous year). This was due to factors including the effect of increased sales, decreased proportional costs, the dissolution of temporal costs incurred in the previous year because of an increased burden on production lines resulting from higher sales in the Americas and exchange rate effects.

Overview of the Fiscal Year Ending March 31, 2015

For the fiscal year ending March 31, 2015, we anticipate a large increase in sales due to newly secured orders from Japanese manufacturers and local manufacturers, particularly in China and other Asian countries.

Medium- and Long-Term Strategies

For the medium and long term, production volume will decrease in Japan as car makers move production overseas, while we also forecast continued high production volume in the North American market. We also anticipate that the market will expand in ASEAN countries and India, and that China will continue its growth as the world's largest market.

Against this background, we will not only expand sales in these emerging regions but also successfully boost profitability by continuing measures that include increasing local procurement and increasing the use of local steel and low-price steel.

In the area of product development, we will supplement our strengths in axle bearings and constant-velocity joints by accelerating development of module and system products, a third pillar of business that will distinguish us from our competitors. And besides standardizing parts to further boost productivity, we will strive to promptly provide customers with technology suggestions and samples that will make NTN an indispensable partner.

Main Product Lineups for Automotive Market

* Photos are cross-sectional models of products.

Transmission



Tapered roller bearings



Thrust needle roller bearings

Steering

Constant-velocity joints for steering*



Seat

Clutch for seat lifter*



Third generation hub bearings*

The world No.1



CVT



Hollow ball screw units*



Wheel applications

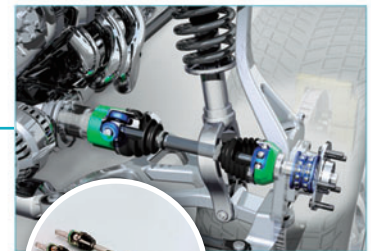

Constant-velocity joints*

The world No.2

Engine, accessories



High-load resin pulleys



Auto tensioner units*



Needle roller bearings for rocker arm

At a Glance

Topics

Development of "Mechanical Clutch Unit (MCU) for Next-generation Steering"

NTN has developed and released the Mechanical Clutch Unit (MCU) for Next-generation Steering, which went on sale in 2013 and has been adopted by Nissan Motor Company for its Direct Adaptive Steering.

The product contributes to the realization of a backup mechanism for the Direct Adaptive Steering. The MCU has a compact layout consisting of an electromagnetic clutch and roller clutch. The electromagnetic clutch is energized when the Direct Adaptive Steering function activates, which releases the roller clutch, which in turn transmits steering input to the tires via electrical signals. If a malfunction is detected in the Direct Adaptive Steering, power to the electromagnetic clutch is turned off and the roller clutch is instantaneously connected to transmit steering input to the tires via a mechanical link. A high load capacity design ensures a high level of reliability when the mechanical link is active.

NTN is aiming for further market deployment of the MCU as a core technology product for next-generation steering systems.



Mechanical Clutch Unit for Next-generation Steering*

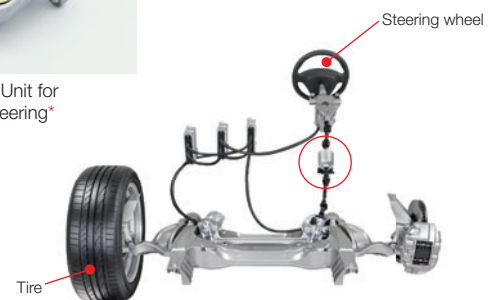

[Example of application]

Research and Development

Worldwide Research and Development into New Products and Technologies that Anticipate Market Needs

Development System Capable of Rapid Response to the Needs of Local Customers around the World

The NTN Group conducts global research and development at four regionally independent, self-contained R&D bases. At the R&D bases in Japan and Europe, we conduct elemental technology and other basic research, as well as research into cutting-edge technologies. At the same time, so that we can quickly respond to customer needs in various regions, the R&D bases are self-contained centers that can carry out independent technological services such as development of individual products, assessment for certification, surveys, and analysis. We are stepping up the functions of the NTN China Technical Center in Shanghai, which is central to collaborations with industry, academia, and government in conducting development projects, and which hosts demonstration testing related to environmental fields.

The research results and technological information garnered from NTN's R&D bases are compiled on databases for sharing among the worldwide NTN Group.

Development for the Industrial Machinery Market Meeting Needs in a Range of Sectors through Advanced Bearing Technologies

Besides the promising growth sector of wind power systems, we are also positioning aircraft, machine tools, rolling stock, construction machinery, robotics, and agricultural machinery as key sectors where advanced bearing technology is in demand. For these sectors we are developing new products and module systems that respond to market needs. One target area for NTN is offshore wind turbines, which is seeing increasing numbers of installations worldwide. For this market, we have developed and plan to introduce the world's smallest class of CMS^{*1}, which remotely monitors the state of the various parts of a wind turbine. We have already begun selling the CMS for both practical use and demonstration test purposes on land-based wind turbines around Japan.

In NTN's core product area of spherical roller bearings, we are expanding our ULTAGE^{*2} series, which boasts the world's highest standard. Besides increasing sales of ULTAGE in key sectors and the steel industry, we are continuing to evolve this product series and develop module and system products in response to new market needs.

*1 CMS: Condition Monitoring System

*2 "ULTAGE" (a name created from the combination of "ultimate," signifying refinement, and "stage," signifying NTN's intention that this series of products be employed in diverse applications) is the general name for NTN's new generation of bearings that are noted for their industry-leading performance.

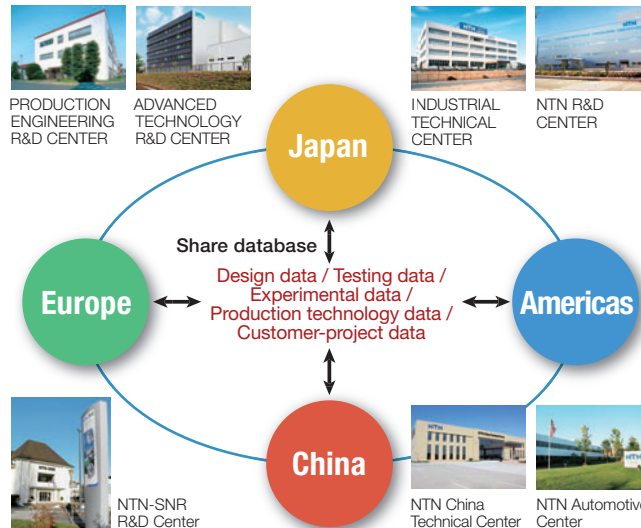

Automotive Applications Providing a Diverse Range of Products that Boost a Car's Energy Efficiency

Besides module products such as Ball Screw Drive Module for Electric Hydraulic Brake for hybrid cars, and the MCU^{*3} for next-generation steering systems, we have developed products that improve cars' fuel efficiency, like a Low Torque Seal Ring that allows transmissions to be smaller and have lower torque, and hub bearings with less friction loss.

For EVs, we have developed an In-wheel Motor System and an electromechanical brake system, and we are working with system suppliers to bring these products to market. We have also conducted demonstration projects in Japan and France of microcompact EVs equipped with our in-wheel system. In the fiscal year ending March 31, 2014, we began a similar demonstration project in Ise City, Mie Prefecture and are aiming for commercialization that will help local tourism promotion.

*3 MCU: Mechanical clutch unit

A Word from a Senior Executive Officer

Contributing to Worldwide Industry through the Power to Develop Proprietary Technologies

The NTN Group has always put the full force of its capabilities into creating products and technologies that are the best in the world and unrivalled among our competitors. In recent years, we have stepped up development of module products and system products, which combine existing products like bearings and sintered materials with peripheral components such as direct-acting parts, gears, motors, and sensors, all of which are operated with control technology. We are actively proposing these module and system products to our customers, who reap the benefits of shorter man-hours for design and assembly, a shorter development period, and lightweight, compact products. We are also offering improved service

solutions through bearing diagnosis and analysis on various types of equipment. An example is releasing CMS, which remotely monitors the state of a wind turbines.

Developments are proceeding at companies in the NTN Group; for example, on magnetic materials that will be used for the power unit of hybrid cars; and on resins and sintered alloys whose specific properties are exploited to make composite-material products. Through research and development activities like these, we are giving birth to high-precision, high-quality products and technologies that will contribute to the advancement of industries around the world.



Yuki Yoshi Hagimoto
Senior Executive Officer

CSR Activities Report

Corporate Governance

G overnance	33
Governance, Compliance	33
Disclosure of Information	39
Officers	40

Focus

1 Managing Energy is a Key Management Challenge	41
--	----



2 Establishing a Global CSR Implementation System to Strengthen Management Foundation	42
--	----



3 Targets for Our 100th Anniversary of Foundation More Female Employees, More Female Managers	43
--	----



Social and Environmental Responsibility

S ociety	44
Quality Management	44
Supply Chain Management	46
Human Resources Management	47
Contributions to Local Communities	49

E nvironment	50
Environmental Management	50
Prevention of Global Warming	56
Reducing Waste	58
Management and Reduction of Environmentally Hazardous Substances	59
Biodiversity	60

We are stepping up corporate governance and compliance throughout the NTN Group worldwide.

Strengthening Corporate Governance

Philosophy and System of Corporate Governance

NTN makes the implementation of highly efficient corporate governance a top management priority and we build systems that make management more efficient and robust.

We also strive to communicate with shareholders, investors, and other stakeholders by providing information in a prompt, accurate manner. This ensures more transparent management.

Continuously Strengthening Management Auditing Functions

NTN employs a corporate auditor-based governance system in which three of the four corporate auditors are from outside the company. Outside corporate auditors bring specialized knowledge in areas such as finance, management, and law, and they conduct audits in collaboration with in-house standing statutory auditors and the Internal Audit Department.

The Board of Directors, which includes two outside directors, makes decisions on important matters and

oversees business execution, and corporate auditors sit on the Board of Directors to give their opinions. In this way, we strive to maintain and improve transparency and fairness of the Company's management supervision system.

We also employ the Executive Officer System to ensure swift decision-making and business execution.

The Board of Directors, based on set regulations, makes decisions on the selection and dismissal of representative directors and directors with special titles, as well as the designation and cancellation of duties delegated to directors. After director candidates are decided on at the Board of Directors meeting, they are nominated and voted in at the general shareholder meeting. This ensures transparency and fairness.

Compensation Based on Regulations

The upper limit for the compensation for officers is voted on at the general shareholder meeting, and the compensation and bonuses for directors are decided on by the Board of Directors based on its regulations. Statutory auditors negotiate their compensation. NTN has no system of retirement benefits.

Corporate Governance Structure

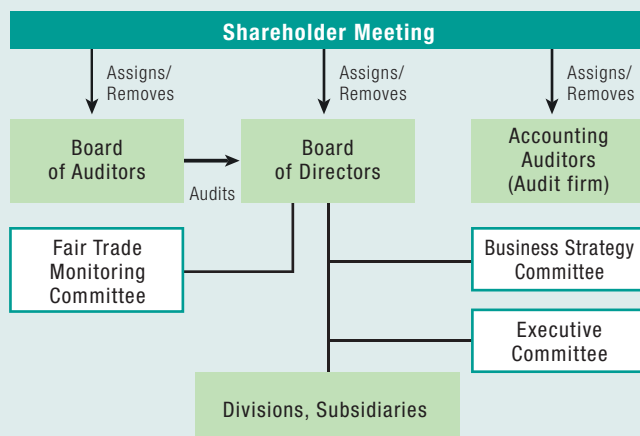

Board of Directors:

The role of the Board of Directors is to make decisions relating to fundamental business policies, statutory matters, and important management issues, and to supervise the performance of duties by its members. The board holds regular meetings at least once per month, with extraordinary meetings also convened at any time when necessary.

Business Strategy Committee:

The Business Strategy Committee discusses fundamental business policies and important management strategies, with meetings held twice per month.

Executive Committee:

NTN introduced the Executive Officer System in the fiscal year ended March 31, 2005 to enable swift decision-making and business execution. Reviews of monthly performance are conducted by the Executive Committee, comprising Directors and Executive Officers.

Corporate Auditors:

NTN has four corporate auditors, two of who are standing auditors (with three of the four being outside auditors). The auditors are responsible for auditing the performance of duties by members of the board. Auditors attend board meetings and express their opinions as part of their efforts to maintain and improve the transparency and fairness of the Company's management supervision system. The system is structured to enable standing auditors to participate and express their opinions during meetings of the Business Strategy and Executive committees. The corporate auditors also strive to increase the efficiency of the overall auditing process, meeting regularly to coordinate their own corporate audits, independent public auditing firm audits, and internal audits. There are no special business relationships or interests between the outside auditors and NTN.

Fair Trade Monitoring Committee:

Chaired by the NTN President, the committee exerts practical control to ensure fair trading in compliance with the Antimonopoly Act and Subcontracting Act, and also monitors and provides advice regarding training and educational activities.

NTN's Efforts to Comply with the Antimonopoly Act

The NTN Group has made compliance a top priority and is striving to strengthen its systems for complying with laws and regulations.

In June 2012, NTN and former executives received an indictment filed by the Tokyo District Prosecutors Office (TDPO) on suspicion of having violated Japan's Antimonopoly Act in relation to the domestic sale of bearings. In March 2013, we received a cease and desist order and surcharge payment order (for ¥7.231 billion) from the Japan Fair Trade Commission (JFTC). Because the assertions by the JFTC and TDPO are greatly different from NTN's views of the facts, NTN is currently asserting our defense in both hearing and criminal proceedings.

Starting in November 2011, NTN consolidated subsidiaries in Europe were suspected of violating EU competition laws and cooperated in an investigation by the European Commission. Following settlement procedures, in March 2014 the European Commission decided to impose fines of 201 million euros for violating EU competition laws with respect to sales of automobile bearings in Europe. NTN's Singapore subsidiary underwent an inspection from Competition Commission Singapore (CCS) starting in February 2013 and in May 2014 CCS issued its decision to impose fines of 455,652 Singapore dollars for the violation of Singapore competition law with respect to sales of aftermarket bearings in Singapore.

NTN subsidiaries in the U.S. and Korea are also under investigation by the relevant authorities in those countries.

As well, NTN and its subsidiaries in the U.S. and Canada are defendants in a number of class action suits.

We at NTN sincerely regret any concern that may have been caused to shareholders by these events.

The NTN Group has been committed and remains committed to ethical business activity and fair competition in compliance with all laws and regulations including the Antimonopoly Act.

(1) The construction of systems to ensure compliance with the Antimonopoly Act

In April 2012, we established the Fair Trade Monitoring Committee to ensure fair trading in compliance with the Antimonopoly Act and the Subcontracting Act. It is under direct control of the Board of Directors and chaired by the president, with directors in charge of the sales and procurement departments in Japan and overseas, and outside directors and attorneys acting as committee members. In the past two years, this committee has convened 12 times.

In April 2014, CSR Headquarters were established in order to improve our ability to expand global activities, comply with laws and regulations, and implement the NTN Group's overall CSR. The Fair Trade Promoting Department became a part of CSR Headquarters.

(2) Continuous compliance activities for the Antimonopoly Act

The Fair Trade Promoting Department leads in-house training for directors, sales departments, and managers. In August 2012, it established five principles for preventing cartels and these were put on cards for employees to recite. In December 2012, it published and distributed the Antimonopoly Act Compliance Handbook. We also monitor progress and conduct guidance of our compliance with laws and regulations; for example, self-audits by employees and in-advance applications by employees to request an approval from the Fair Trade Promoting Department to participate in meetings with potential contacts with competitors, such as customer/supplier situations or collaborating for joint supply to OEMs at an OEM's requests.

Under our in-advance application system, we have employees who will take part in meetings with other companies, such as a Trade Association Meeting, sign and submit an agreement that says, "I will not have any discussions, such as regarding pricing information that would cause suspicion of NTN being in violation of the Antimonopoly Act. If such a topic should arise, I will explain that I cannot take part in such discussion and immediately excuse myself." It is also mandatory that NTN employees report any contacts different from those on the in-advance application and any unexpected contacts without an in-advance application so that we can have an overall picture of contacts with competitors.

Any reports or consultations from directors and employees are received through the consultation services of the Fair Trade Promoting Department and through a helpline, and we can provide a prompt answer or start investigation quickly.

The Audit Department also controls NTN's compliance system by auditing progress of the improvement measures taken in the relevant NTN departments.

At NTN's overseas bases, we are working to ensure control over our global activities by strengthening compliance systems that ensure we abide by antimonopoly and competition laws in various countries. We are establishing a system of responsibility for each of our business regions under the guidance of the Fair Trade Promoting Department, and our subsidiaries are holding compliance training for employees, conducting audits on matters such as the in-advance applications mentioned previously, and conducting self-audits to ensure ongoing compliance.

The NTN Group will use these various systems to conduct continuous education and awareness activities that strengthen overall control over our compliance.

Internal Control

Creating and Implementing Systems a Top Priority

In line with the basic framework for internal control as outlined in “On the Setting of the Standards and Practice Standards for Management Assessments and Audits Concerning Internal Control Over Financial Reporting (Council Opinions),” published by the Business Accounting Council, NTN has a basic policy for the structure of internal control. Based on this policy, we have made the creation and implementation of an internal control system a top priority of our risk management and compliance.

The Internal Audit Department is responsible for internal audits, and has been established as an independent auditing organization to audit business execution throughout the Company.

Pursuing Risk Management

Philosophy and System of Risk Management

System Implementation in Line with Basic Policy and Management Rules

In line with NTN’s Basic Policies, we have formulated our Risk Management Policy, and we have established the Risk Management Rules, which set out the systems and standards to follow in case of an emergency.

Based on these policies and rules, we have created an integrated system that prevents the occurrence of emergencies and provides.

Risk Management Policy

NTN Corporation hereby establishes the basic policy of NTN group to precisely manage the risk prevention and to quickly respond at the outbreak of various risks (i.e., the events that may prevent the accomplishment of business purpose and the operation of business) surrounding the business of NTN group.

- ① We shall make an effort to eliminate or reduce the various risks to the stakeholders, such as customers, suppliers, shareholders, investors and local communities, and executives and employees.
- ② We shall maintain the risk management system for prompt and proper measures against the risks and implement the company-wide and general risk management.
- ③ We shall implement the risk findings, risk analysis, risk assessment and risk measures according to the risk management plan and take proper preventative measures.
- ④ In the case of risk arising (emergency), we shall keep to minimize the damage expansion by initial risk countermeasures including the proper information transfer to inside and outside the Company.
- ⑤ We shall make an effort to keep and develop the stable business by monitoring the proper structure and implementation of the risk management on a daily basis.

Risk Management System

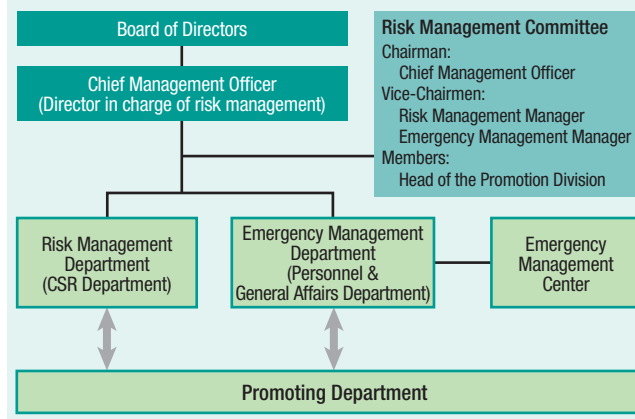

Risk Management Approach

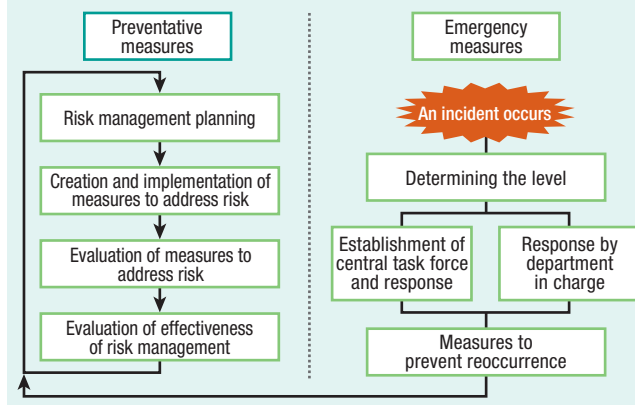

Setting Key Management Risks to Handle with the PDCA Cycle

We established the Risk Management Committee as an advisory body for managing risk. The committee leads focused risk measures. In the fiscal year ended March 31, 2014, the committee held meetings in May and October, and it checked plans and progress in dealing with focused risk matters, and ensured that other risk matters were being dealt with.

Main Focused Risks (Fiscal Year Ended March 31, 2014)

- Violation of Antimonopoly Act
- Violation of Subcontracting Act
- Violation of labor-related laws
- Insider trading
- IT problems
- Risks stemming from large-scale disasters
 - Default on contracts
 - Stoppage of distribution
 - Operational stoppage of NTN facilities
 - Bottleneck/standstill on the supply chain



Information security education e-learning site

Dealing with Key Risks

Legal Violations, etc.

Systems to Prevent Dishonesty and Ongoing Education

See pages 34 and 38 for NTN's efforts to prevent dishonest practices, including the violation of various laws.

IT Problems

Measures to Strengthen Information Security

In the fiscal year ended March 31, 2014, we formulated our Basic Policy on Information Security in order to boost in-house rules on information security.

All NTN employees, including temporary employees, have access to the Information Security Guide on the NTN intranet, and can also take e-learning courses in information security, all as part of NTN's efforts to make everyone fully aware of our information management methods. As well, sales sites in Japan have a Classified Information Protection Manual that details how to prevent information leaks. And all employees who carry company laptop computers are required to take the NTN Mobile Information Pledge.

Risks Stemming from Large-Scale Disasters

Considering Measures to Deal with Work Stoppages

With regards to hazard risks (external risks), assuming that a large-scale natural disaster causes work stoppage at multiple sites, we have measures aimed at preventing damage, minimizing damage, and restarting work. For example, situations that could arise in a natural disaster include defective products, leakage of hazardous or dangerous substances, damage or loss of IT equipment and electronic information, cut-off of procurement supplies, and stoppage of distribution functions. We are looking individually at measures for each of these situations.

To make business continuity plans (BCPs) for the prompt recovery and continuation of business following a natural disaster, NTN divisions share their policies on current and possible future BCPs and this cooperation leads to the formulation of updated measures. We also constantly improve systems for confirming the safe whereabouts of employees in case of a natural disaster.

CSR Management

CSR a Key to Corporate Philosophy System

NTN's corporate philosophy is "We shall contribute to international society through creating new technologies and developing new products." To realize this philosophy, in June 2006 we formulated the CSR Policy, one of NTN's Basic Policies.

Corporate Philosophy System

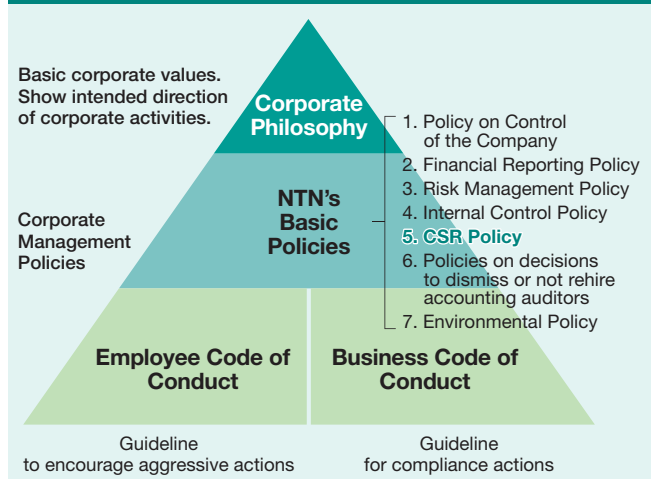

CSR Policy

- ① **Legal compliance/Policy for activities:** We shall comply with laws and regulations, endeavor to engage in fair competition, and carry out our business activities in an honest and ethical manner.
- ② **Customers:** We shall strive to develop new technologies and new products, as well as to provide safe and reliable products.
- ③ **Business partners:** We shall engage in fair and free competition, and at the same time establish excellent partnerships with our business partners.
- ④ **Stockholders/Disclosure of information:** We shall work to develop this corporation and increase stockholder return, while at the same time communicating broadly with society and actively disclosing information.
- ⑤ **Employees:** We shall value the individuality and diversity of our employees, work to create a safe and pleasant work place, and achieve comfort and prosperity.
- ⑥ **The environment:** With ample consideration to preserving the global environment and protecting the ecosystem, we shall work toward the creation of a sustainable, progressing society.
- ⑦ **Society:** We shall make every effort to interact meaningfully with society on a local level, and to engage in activities that contribute to society.
- ⑧ **International activities:** We shall, as a matter of course, obey all international rules as well as the laws of each country and each region that we operate in; we shall also respect local cultures and practices and contribute to local development.

Disseminating the Codes of Conduct Accordance with Basic Policies

In accordance with its CSR Policy, NTN formulated the Employee Code of Conduct, the guidelines for carrying out CSR activities, and the Business Code of Conduct, which all officers and employees must abide by.

These are written in the CSR Guidebook and the Pocket CSR Card that all NTN Group employees in Japan possess so that they can put CSR into action into their daily work.

Disseminating Codes of Conduct at Overseas NTN Group Companies

All NTN Group companies overseas disseminate Codes of Conduct that match their particular situation. For example, NTN-SNR ROULEMENTS in France formulated its Codes of Conduct in 2011 and put them in booklets that are distributed to all employees.

CSR Promotion Structure

CSR Department and CSR Committee Lead Activities

In 2006, we began our CSR activities in earnest with the establishment of the CSR Management Rules and the CSR Department. The CSR Department is a dedicated division for overseeing the NTN Group’s CSR activities as well as advancing and strengthening them. The CSR Committee is chaired by the head of the CSR Department and made up of the heads of relevant divisions. It systematizes CSR activity plans and CSR policies, and it deliberates on CSR issues across all divisions.

We pursue CSR throughout the entire NTN Group in Japan by appointing CSR managers and persons in charge of CSR

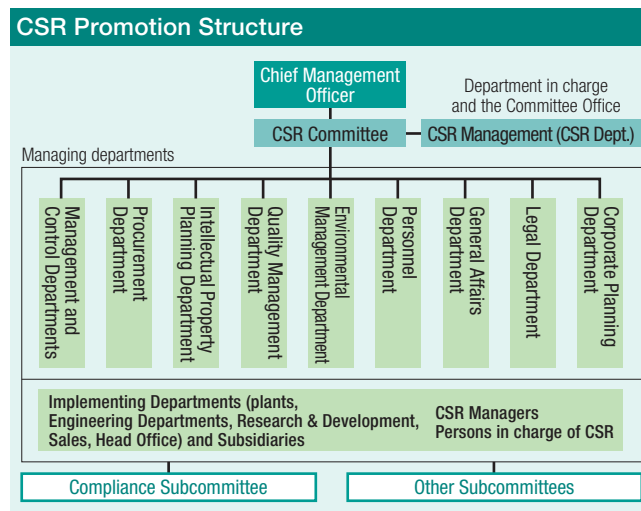

at all of our sites and at NTN Group companies in Japan.

In April 2014, the CSR Department was integrated into the CSR Headquarters along with the Legal Department and the Fair Trade Promoting Dept. It will collaborate with other divisions and play a key role in the robust management of NTN. (See page 42 for details.)

CSR Manager Appointed to Overseas Office of General Managers

NTN subsidiaries around the world plan and conduct CSR activities according to their own particular situation.

With laws and regulations relating to competition, corruption, and bribes becoming increasingly stricter around the world, starting in the fiscal year ending March 31, 2015 NTN has

Employee Code of Conduct

- 1 We respect social ethics and act as good members of society.
- 2 We have noble ambitions and always make efforts to brainstorm and achieve the set target.
- 3 We accept changes, have broad vision and act voluntarily.
- 4 We deepen mutual understanding and enhance the vitality of our work site.
- 5 Management and supervisors in particular, as faces of the corporation, improve their qualifications, make efforts to develop individuals, always take care of safety and show leadership.

Business Code of Conduct

- | | | | |
|--|---|--|--|
| 1 Compliance with laws and norms | 8 Respect for intellectual property rights | 14 Promotion of environmental preservation | 21 Strict distinction between public and private matters |
| 2 Pursuit of quality and safety | 9 Proper control of confidential information | 15 Positive contribution to society | 22 Confronting harmful social forces |
| 3 Compliance with the Anti-Trust Law | 10 Ensuring security by strengthening export controls | 16 Compliance with labor-related laws and company work rules | 23 Proper utilization of our information system |
| 4 Fair trade with suppliers | 11 Compliance with industrial laws | 17 Realization of a safe and positive work environment | 24 Prohibition of insider trading |
| 5 Honoring agreements | 12 Compliance with corporate accounting principles | 18 Respect for human rights | 25 Self-restraint regarding entertainment and gifts |
| 6 Refusal to engage in improper conduct with business partners | 13 Compliance with international rules | 19 Prohibition of sexual harassment | 26 Lawful donations/political donations |
| 7 Proper labeling and specification | | 20 Proper control of information about individuals | |



Helpline screen on the NTN intranet

decided to strengthen internal control at overseas subsidiaries under the guidance of the head office.

As a first step, in April 2014 we appointed an internal control section in the Office of General Managers of overseas subsidiaries. With the aim of improving the system of compliance at subsidiaries representing different world regions, these internal control sections will work with the CSR Department to help raise the group-wide level of CSR activities at NTN. (See page 42 for details.)

Furthering Compliance

Philosophy and System of Compliance

NTN defines compliance as not only abiding by laws and regulations, but also as having a system for thorough compliance with all social norms and rules.

Compliance Subcommittee Carries Out CSR Activities

NTN has the Compliance Subcommittee as an advisory body under the CSR Committee. This subcommittee is charged with comprehensively promoting and managing compliance initiatives for the entire Group.

Helpline Established

We have set up helplines inside and outside the company to offer consultation on compliance matters. In the fiscal year ended March 31, 2012, our helpline management rules were revised so that calls to the helpline related to competition laws (Antimonopoly Act, Subcontract Act) could be reported to the Fair Trade Monitoring Committee.

Besides the helpline, we also have a direct line for consultation with the Fair Trade Promoting Department.

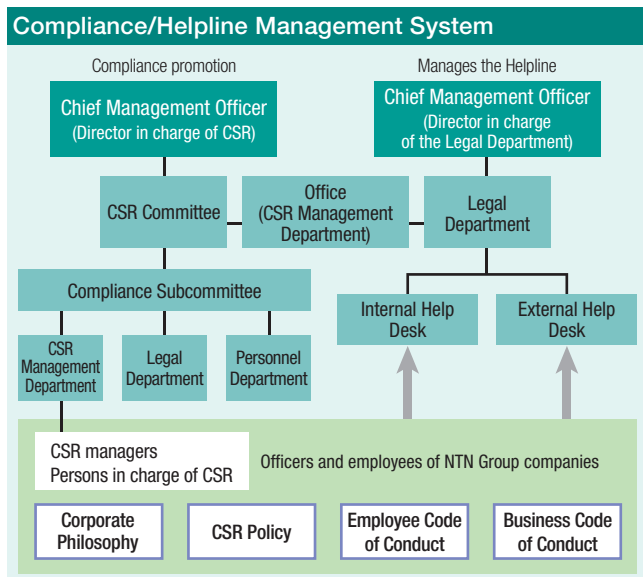

Ongoing Education Includes Compliance Comprehension Checkups for Management

NTN focuses on compliance-related education for both officers and employees. At NTN sites and Group companies in Japan, chiefly CSR managers and persons in charge of CSR plan educational activities and lead sessions on a range of topics for all levels of employees.

One focus is training for employees being promoted to managerial positions, who take self-learning with company-provided textbooks and online CSR comprehension tests. To ensure participants achieve a defined level of knowledge, they are required to take tests until they get a passing grade.

In addition, employees can raise their awareness by studying the latest news on compliance matters and case studies of legal violations on the compliance database of the intranet. Besides company-wide education, each workplace has its own systems in place, such as employee self-checks and feedback sessions that ensure its workers are constantly raising their awareness of compliance.

In the fiscal year ending March 31, 2015, we are administering periodic questionnaires to assess the results of our educational programs. The questionnaire data will be used to compare changes since the last questionnaire, administered to about 4,000 NTN employees in Japan in 2010, to help us improve future programs.

Compliance education is a focus at our overseas bases as well. In the fiscal year ended March 31, 2014, the Fair Trade Promoting Department led education sessions on the Antimonopoly Act. In the fiscal year ending March 31, 2015 and onwards, we plan to conduct compliance education led by internal control sections which we established in April 2014.

Results of Compliance Education (Fiscal Year Ended March 31, 2014)

Type	Content	Targets	Month	Number of participants
New employee training	<ul style="list-style-type: none"> As part of new employee training, time is set aside to teach CSR basics and NTN CSR activities. The focus is on compliance, and participants are taught to place high priority on CSR in all that they do. 	All new employees	April	81
Training for employees promoted to managerial positions	As key players in the implementation of compliance-centered action, managers reaffirm their knowledge of necessary compliance information.	Employees promoted to managerial positions	July-August	47

We strive to realize an open general shareholder meeting and release accurate information in a fair and timely manner.



IR briefing in the Noto district of Ishikawa Prefecture

General Shareholder Meeting

Our Goal: An Open General Shareholder Meeting

We have taken the following steps, such as making it easy to take part in general shareholder meetings, to streamline procedures for shareholders to exercise their voting rights.

Measures to Streamline Shareholder Voting Rights	
Swiftly mailing our general shareholder meeting notice	The law says shareholders must be notified two weeks prior to a shareholder meeting, but we send our notices seven days earlier than that (three weeks prior).
Scheduling meetings that avoid the dates that most companies set for such gatherings	To make it possible for as many shareholders as possible to attend a shareholder meeting, we avoid dates that most companies hold their meetings, and we take into account factors such as settlement and audit schedules.
Broadly notifying of our general shareholders meeting through the internet and other media	We publicize notices of our general shareholder meeting and other information through the Tokyo Stock Exchange and our website to reach as many shareholders and investors as possible.
Using electronic voting via the Internet	<ol style="list-style-type: none"> 1. We accept shareholder votes via mail and the Internet through the 5:25 p.m. close of business up to the day before the general shareholder meeting. 2. We have methods for dealing with cases in which there are overlapping votes by mail and the Internet, or where shareholders vote multiple times over the Internet. 3. We participate in the Electronic Voting Platform, which is managed by Investor Communications Japan (ICJ), an entity formed by the Tokyo Stock Exchange and other bodies, and which makes it possible for institutional investors to vote.
Other efforts	At the general shareholder meeting, we present some of the business report and settlement data as graphs, photos, and other visuals to complement the meeting chairperson's explanations.

IR Activities

Disclosing Accurate Information in a Fair and Timely Manner

We respond to the desire of shareholders and investors to receive accurate information in a fair and timely manner.

Timely Information Online

We focus on making information available for anyone to read by disclosing it on the Internet.

We satisfy timely disclosure requirements under Securities Listing Regulations by presenting information through the Company Announcements Disclosure Service on the website of the Tokyo Stock Exchange. On the NTN website, we release

timely information including our securities, quarterly report, business results, the NTN Report, annual and business reports, and materials from our results meetings.

For those who register on our website for the NTN newsletter, we send an email with the latest news as soon as it appears on our home page.

Explaining Policy at Seminars and Briefings

We provide as many opportunities as possible for stakeholders to hear about NTN management policy from the company's top management.

At seminars for individual investors hosted by large securities companies, NTN top management talk about our company. They also host visits to production sites in Japan.

On a regular basis, our executives convene results meetings, teleconferences, one-on-one gatherings, and other regular briefings for analysts and institutional investors. They also respond whenever there are questions or requests from investors. In the fiscal year ended March 31, 2014, we released as much information in as many ways as possible both in Japan and overseas, holding IR technology briefings and factory tours, and taking part in events sponsored by securities companies. We plan to step up our IR activities with events including an overseas IR roadshow.

NTN Included in SRI Indices

NTN Continues to be Included in Numerous SRI Indices

NTN has been included in several socially responsible investment (SRI) indices in the stock market for its aggressive efforts to protect the environment and contribute to society.

SRI Indices (As of March 2014)

MEMBER OF
Dow Jones Sustainability Indices
 In Collaboration with RobecoSAM



FTSE4Good



Officers (As of June 25, 2014)

Officers

Yasunobu Suzuki

Chairman

Hiroshi Ohkubo

President
Representative Director

Kenji Okada

Executive Vice President
Representative Director
Research and Development,
Quality Management,
Environmental Management
Corporate General Manager,
Industrial Business Headquarters

Hironori Inoue

Executive Director
Representative Director
Production, Procurement,
Logistics & Cost Planning

Fukumatsu Kometani

Executive Director
Corporate General Manager,
Aftermarket Business Headquarters
China, ASEAN & Oceania, India &
West Asia, Americas, Europe & Africa

Yoshinori Terasaka

Managing Director
Corporate General Manager,
Automotive Business Headquarters
EV Module Business Headquarters

Keiji Ohashi

Managing Director
Administration

Itsuji Gotou

Director
Corporate General Manager,
Finance Headquarters
Internal Audit Department

Hiroshi Nakano

Director
Corporate General Manager,
CSR Headquarters

Hideaki Miyazawa

Director
Deputy Corporate General Manager,
Automotive Business Headquarters
Americas Region

Hisaji Kawabata

Director
Outside Director

Akira Wada

Director
Outside Director

Akio Imanishi

Standing Audit &
Supervisory Board Member
(Outside)

Mizuho Hikida

Standing Audit &
Supervisory Board Member

Tadao Kagono

Audit &
Supervisory Board Member
(Outside)

Norifumi Ishii

Audit &
Supervisory Board Member
(Outside)

Executive Officers

Yukiyoshi Hagimoto

Senior Executive Officer
Research and Development,
Quality Management,
Environmental Management

Tetsuya Kondo

Senior Executive Officer
Deputy Corporate General Manager,
Aftermarket Business Headquarters

Hidefumi Tsuji

Senior Executive Officer
General Manager, China Region
Chairman,
NTN (CHINA) Investment Corp.

Eiichi Ukai

Senior Executive Officer
General Manager,
ASEAN & Oceania Region
General Manager,
India & West Asia Region

Takehiko Umemoto

Senior Executive Officer
Deputy General Manager,
Automotive Business Headquarters
General Manager,
EV Module Business Headquarters

Natsuhiko Mori

Senior Executive Officer
General Manager,
New Product Development R&D Center
Composite Material Product Division

Tetsuya Sogo

Senior Executive Officer
General Manager, Americas Region
President, NTN USA CORP.

Isao Ozako

Senior Executive Officer
Deputy General Manager,
Industrial Business Headquarters
General Manager, KUWANA WORKS

Takayuki Matsuo

Executive Officer
Deputy General Manager,
Corporate Strategy Headquarters

Yoshinobu Akamatsu

Executive Officer
General Manager,
Product Innovation Strategy Department

Toshinori Shiratori

Executive Officer
General Manager,
Corporate Strategy Headquarters
Manager,
Information Technology Department

Isao Koiwai

Executive Officer
Deputy General Manager,
Automotive Business Headquarters
General Manager, IWATA WORKS

Etsu Harima

Executive Officer
Deputy General Manager,
China Region
Director,
NTN (CHINA) Investment Corp.

Pete Eich

Executive Officer
Deputy General Manager,
Americas Region
President,
NTN BEARING CORP. OF AMERICA

Makoto Okasaka

Executive Officer
Deputy General Manager,
Automotive Business Headquarters

Kouji Kametaka

Executive Officer
Deputy General Manager,
China Region
Director,
NTN (CHINA) Investment Corp.

Jianping Zhu

Executive Officer
Deputy General Manager,
China Region
Director,
NTN (CHINA) Investment Corp.

Alain Chauvin

Executive Officer
General Manager,
Europe & Africa Region
President,
NTN-SNR ROULEMENTS

Kazuki Kawashima

Executive Officer
Deputy General Manager,
Industrial Business Headquarters
Manager,
Cost Development Department

Eiichi Nakamizo

Executive Officer
Deputy General Manager,
Industrial Business Headquarters

Yusuke Iyama

Executive Officer
Manager, Secretarial Staff

Kazuki Hagihara

Executive Officer
Deputy General Manager,
Americas Region

Katsuaki Miyake

Executive Officer
Deputy General Manager,
Automotive Business Headquarters
General Manager, OKAYAMA WORKS

Response to Energy Problems

Managing Energy is a Key Management Challenge

Focus 1

With steep rises in electricity costs, we are looking long term in making energy savings a key challenge in achieving business continuity.

The Most Important Environmental Challenge

The NTN Group uses large amounts of energy in processing metals, and since we began company-wide environmental protection activities in the 1990s we have continued to make energy savings and CO₂ emission reductions top environmental priorities. Recent years have seen Japan struggle with achieving a stable supply of energy, and electricity costs have increased sharply due to nuclear power plant stoppages and increases in fuel prices. Energy management has thus become an even more important factor to business continuity, and in response we are putting greater effort than ever into saving energy and reducing CO₂ emissions.

Long-Term Measures for Energy Savings and Adoption of Renewable Energy

In the fiscal year ended March 2014, we installed an EneMeter (energy usage meter) in our ADVANCED TECHNOLOGY R&D CENTER, allowing us to see how much electricity our air conditioning (a major consumer of power) is using on each floor of the building. This data will be used to improve energy efficiency. We are also continuing to study new energy-saving methods and technologies for our sites in Japan and around the world. (See pages 56 and 57 for details.)

We are also installing solar power and other renewable energy equipment when and where necessary. In the fiscal year ended March 31, 2014, while we did not install any new solar power generation equipment ourselves, we signed a contract with a solar power producer to rent our factory roofs for solar power generation equipment totaling approximately 1,500 kW. This is one way we are contributing to the spread of renewable energy in society as a whole.

NTN Energy-Saving and CO₂-Reduction Efforts

- ① Promote improved awareness of the NTN Group's Environmental Policy and set environmental targets.
- ② Obtain ISO 14001 certification.
- ③ Install energy-saving equipment.
- ④ Install renewable energy equipment.
- ⑤ Contribute to energy savings and CO₂ reductions in society as a whole; for example, collaborate in EV demonstration project, plant trees.

Solar panels at NTN AKAIWA CORP.

Breakdown of Energy Sources Used by NTN Group in Japan

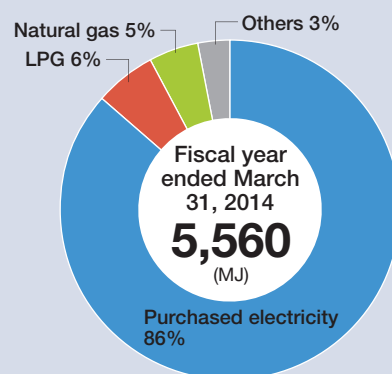

Renewable Energy Generated

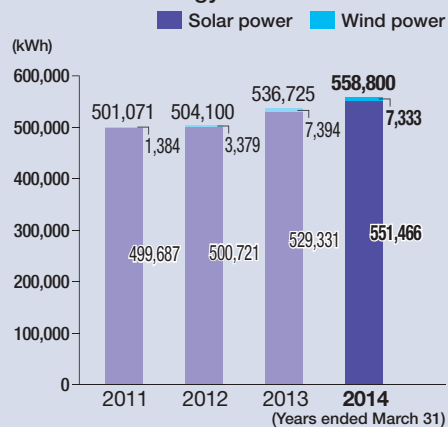

A Word from a Staff Member at the ADVANCED TECHNOLOGY R&D CENTER

Aiming for Advanced Energy Savings through Aggressive Adoption and Development of Environmental Technologies

At the ADVANCED TECHNOLOGY R&D CENTER, we make as much use as possible of renewable energy such as solar and wind power as a way to reduce CO₂ emissions. In January 2014, we installed an EneMeter to see how much each of our divisions was consuming, and this allowed us to create measures focusing on the equipment and building sections consuming the most energy. In December 2013, together with the Mie prefectural government, we installed micro-hydroelectric generation equipment on irrigation canals and have been testing them as power sources for outdoor lighting in Kumano city and as possible emergency power sources in natural disasters.

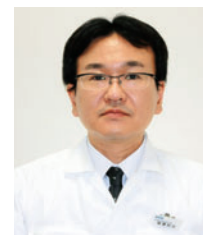

Tomoji Fukuzawa
Manager, Planning and Control Group,
ADVANCED TECHNOLOGY R&D CENTER

Strengthening CSR Management

Establishing a Global CSR Implementation System to Strengthen Management Foundation

We're establishing a worldwide system of corporate governance and compliance so that we can steadily grow and contribute to society.

Urgent Need to Revise CSR Management System in Face of NTN's Expanding Organization

Under our Corporate Philosophy we have striven for "contribution to society based on the steady growth of our business" and "a corporate organization essential as an international company." In recent years, however, as we establish more sites around the world, these Corporate Philosophy efforts have achieved different degrees of success in different regions around the world. In particular, we urgently need to strengthen our global corporate governance and compliance, both indispensable to minimizing management risk and building robust management. To this end, in April 2014 we established a new division, the CSR Headquarters, which encompasses the former CSR Dept. and Legal Dept., and the newly established Fair Trade Promoting Dept.

Key Challenges: Risk Management, Compliance, Fair Trade, and Social Contribution

CSR Headquarters is in charge of matters related to risk management, dissemination and implementation of compliance, fair trading, and social contribution. In April 2014, we appointed an internal control section in the Office of General Managers (the Americas, Europe/Africa, China, ASEAN/Oceania, India/West Asia). The job of these internal control sections is to monitor the state of CSR activities at NTN subsidiaries in the respective regions, lead CSR education and training, and overall make CSR an integral, widespread aspect of the subsidiaries' business.

CSR Headquarters can now work with this new overseas internal control sections to gauge the state of overall group activities, determine which activities take priority, and promote action to improve the level of CSR. This will allow for better information exchange and human resource interaction, and more widespread awareness of CSR.

Strengthening Systems for Global Governance and Compliance

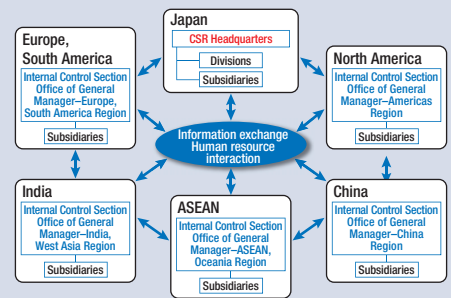

Key Efforts and Challenges

- Strengthen risk management**
 Revise Risk Management Rules and CSR Management Rules
 Establish a global system for risk management
- Implement compliance**
 Establish and strengthen a global system for compliance
 Utilize FTAs and establish and improve a secure export control system
 Provide high-quality legal services
 Improve employees' knowledge of legal matters
- Fair trade**
 Establish and strengthen a global system for compliance with the Antimonopoly Act
 Respond to criminal court action and administrative hearings, and to regulatory authorities in countries overseas
- Contribute to society**
 Carry out social contribution activities

A Word from a Staff Member in an Internal Control Section

Confirm Overseas Company Situations Firsthand and Formulate Effective Response Measures

I am in charge of leading CSR activities, such as strengthening the internal control system, in the Internal Control Section of the Office of General Manager—China Region. In doing so, I work closely with the CSR Headquarters and the compliance division of NTN (China) Investment Corporation.

Because I am here in China, I can closely gauge the situation and therefore plan and implement effective control and monitoring activities. I also help work on social contribution activities.



Tetsuo Yamamura
 Manager,
 Internal Control Section,
 Office of General
 Manager—China Region

Meeting in the internal control section in China



Fostering Diversity

Targets for Our 100th Anniversary of Foundation More Female Employees, More Female Managers

Focus **3**

The fiscal year ending March 31, 2018 is the target year for our new action plan. We will make use of female employees' talents company-wide to achieve further growth.

Tap Into Diverse Viewpoints and Ways of Thinking

In April 2014, we launched the Diversity Team project. To adapt to today's global market, we often must update our traditional ways of doing things. To come up with diverse ideas and points of view, it is essential that we utilize human resources who possess a range of views and philosophies and not get trapped in conventional thinking of men only or managers only. We believe that one way we can do this—and in the process solve the problem of a falling birth rate and boost corporate value—is to make the most of the women who comprise about 10% of our workforce. This is therefore the key target of our Diversity Team project.

Double the Number of Female Managers by the Fiscal Year Ending March 31, 2018

Under the Diversity Team project, we are working towards the target of doubling the number of female managers from the current 20 to 40 by 2018, the 100th anniversary of our foundation.

To start off, we plan to increase the number of women we hire, particularly science majors. We want to get these new young employees into product development as soon as possible and let them speak their opinions freely and aggressively so that they will become more motivated and interested in pursuing a career. In fact, we have already sent female engineers out on the front lines of sales. For example, in June 2013 one of our female engineers had a business trip to U.K. and gave a technical presentation to the customer on the mass-production process of our highly reputed aircraft bearings. We are also urging as many women as possible to participate in our ongoing overseas training system* so that they will become capable of working in any NTN global work setting.

In addition, we strive to change employees' way of thinking through in-house efforts such as training and seminars for both men and women. Work-life balance is another area we are putting increasing emphasis on.

Females as Percentage of All Employees and as Percentage of All Managers (NTN Corporation only)

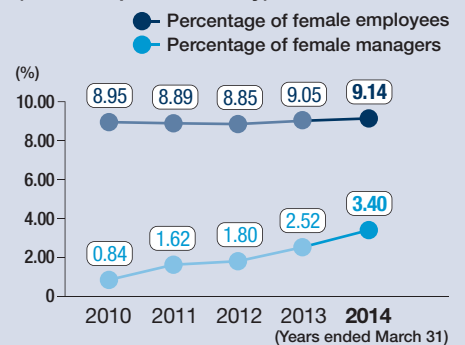

Three Pillars of Diversity

(1) Diversity Team kickoff

Planning and implementation of training plan
Boosting of management capabilities
Increasing number of female managers

(2) Plan to change male and female employees' way of thinking

Training sessions, seminars

(3) Planning of work-life balance measures

Region-specific managers, maternity and childcare support programs, Bear Kids Land (daycare facility on premises of IWATA WORKS), etc.

* Overseas training system: Young employees are selected from among applicants and sent to an overseas subsidiary for one year so that they can experience another country and learn how to communicate in a foreign culture.

Diversity Team members



A Word from a Diversity Team Member

Establishing a Gender-Neutral Workplace with Flexible Work Schedules Where We Can Use Our Talents to the Fullest

Under the Diversity Team project, my job is to get women more involved at NTN.

Companies have been focusing on work-life balance and flexible working schedules in recent years. I know firsthand about these trends because I have been taking advantage of NTN's reduced working hour system for child-rearing. I hope to use my personal experience in this area to help my team members create a range of valuable measures in support of diversity.



Aya Oota
Global Human Resource Development Dept.



Screen shot of G-QUICK website

We're working throughout the entire value chain to ensure quality on a global scale.

Quality Management Policy

Basic Policy of Quality, Quality Management Policy

Stipulate Basic Policy and Formulate Annual Management Policy

Under our Basic Policy of Quality, which forms the basic concept of all our manufacturing, we formulate quality management policies for each fiscal year and set down themes for maintaining and raising product quality.

In the fiscal year ended March 31, 2014, our target was to reduce the number of complaints in Japan and overseas to improve the NTN brand image and generate profit. By conducting quality audits and confirming that work processes were in line with our standards manual, we achieved our target for the second half of the year. We will strive to eliminate the number of complaints and defective products.

Basic Policy of Quality

Pursuit of appropriate quality that can suffice the functions and specifications required by customers.

- ▶ Quality that meets diversified needs in markets (Conformable quality)
- ▶ Superior quality to competitors' (Competitive quality)
- ▶ Quality that benefits producers (Economic quality)

Quality Slogan:

Quality is our future — Quality paves the way for our future.

Quality Management Policy in the Fiscal Year Ended March 31, 2014

As we start operations at new production bases around the world, we aim to contribute to the NTN brand and corporate profit by having all employees work towards our important quality theme of "Ensure global quality" and by eliminating all complaints.

▶ Point

Verify quality assurance and regularly confirm target achievements amidst increase in number of new bases as NTN globalizes.

Quality Management Policy for Fiscal Year Ending March 31, 2015

With the basic goal of maintaining and boosting trust among customers, we aim to improve the NTN brand value and contribute to corporate profit by having all employees strive to "ensure global quality," by eliminating all complaints, and by reducing the number of defective products.

Quality Management System

Management Certification for Various Production Items

Working Towards ISO 9001, ISO/TS 16949 and Other Standards

NTN Group works to achieve certification for quality management standards for its various production items.

Major Certification Achieved in Fiscal Year Ended March 31, 2014

ISO 9001 Certified at 32 production bases, 2 sales bases

Region	Base	Date of Certification
Japan	NTN HOUDATSU SHIMIZU CORP.	Fiscal year ended March 31, 2014
Japan	NTN AKAIWA CORP.	Fiscal year ending March 31, 2015 (scheduled)
Japan	NTN HAKUI CORP.	Fiscal year ending March 31, 2015 (scheduled)
China	Nanjing NTN Corp.	Fiscal year ended March 31, 2014

ISO/TS 16949 Certified at 24 production bases

Region	Base	Date of Certification
U.S.A.	NTA PRECISION AXLE CORP.	Fiscal year ended March 31, 2014
Japan	NTN AKAIWA CORP.	Fiscal year ending March 31, 2015 (scheduled)
India	Chennai Plant, NTN NEI Manufacturing India Private LTD.	Fiscal year ending March 31, 2015 (scheduled)

Besides certification for the ISO 9001 quality management system at production and sales bases in Japan and overseas, we are aggressively working to achieve certification for ISO/TS 16949, a quality management standard that automotive manufacturers demand.

And in 2010, NTN became Japan's first bearing manufacturer to obtain certification under the International Railroad Industry Standard (IRIS), the quality standard for the European railway industry. Together with the quality management certification of the Association of American Railroads (AAR) received in 1986, this shows we are a high-quality supplier to the railroad industry. NTN has also been certified for the AS/JISQ9100 and NADCAP standards for aerospace quality management.

Global Quality Management

Electronic System for Integrated Management of Quality Information

To speed up initial response to quality proposals at our worldwide bases and to streamline quality control work in the NTN Group, in January 2012 we installed the G-QUICK quality information control system.

In the fiscal year ended March 31, 2014, we added to the system a function that sends emails to registered users prompting them to update their information so that we can periodically compile on the system things like our complaint responses and customer reactions to these.

Dissemination of Basic Policy of Quality throughout Worldwide NTN Group

We have published Japanese, English, and Chinese versions of our Basic Policy of Quality and our Quality Control Handbook. These have been distributed to approximately 100 companies including NTN worldwide manufacturing, engineering, and distribution divisions, and suppliers. In the fiscal year ended March 31, 2014, we added a Thai version of these publications, and we plan to make Portuguese and Spanish versions. We have also put quality education materials on the e-learning section of our intranet.



Mobile training van

Working with Suppliers

NTN Group strives to boost quality by cooperating with the suppliers who provide us with raw materials and parts.

Every November is Quality Month at NTN, when we hold supplier quality improvement meetings to give suppliers the knowledge and know-how they need to improve their quality. In the fiscal year ended March 31, 2014, 100 suppliers took part.

As well, quality audits are conducted by the suppliers themselves using the NTN Group's check sheet for quality criteria. Based on these self-audit results, NTN conducts its own on-site audits at the location of suppliers so that we can help them continuously solve their quality issues. In the fiscal year ended March 31, 2014, we conducted on-site audits at 264 suppliers.

Enhancing Customer Satisfaction

Determining Customer Needs

NTN Sales Persons and Engineers for Each Customer

At NTN Group sales companies around the world, we appoint a sales person and an engineer to be in charge of each of our customers and sales agents. This allows us to quickly and accurately determine the needs and problems of each customer and thus offer the best responses and solutions.

We constantly work to improve the skills of these sales people and engineers. In Japan, we conduct TQM (Total Quality Management) activities, which include meetings and education gatherings at which sales people reflect on their weekly dealings with customers and think from the customer's perspective as a way to improve service. In the fiscal year ended March 31, 2014, we analyzed the situation of our customers in the current environment of the industry and focused on specifically how NTN could help them improve their situation.

NTN Engineers Provide Problem-Solving Opportunities

NTN Group holds periodic sessions where customers can get to know our products and technologies better and speak directly about their needs with our engineers. NTN companies hold traveling product exhibitions and technical seminars. For example, NTN BEARING CORP. OF AMERICA (NBCA) tours customer sites around the U.S.A. to give training on bearing basics and bearing use. NBCA is receiving an increasing number of requests for these training sessions from customers.

Customer Satisfaction Surveys

Once a year, we conduct customer satisfaction surveys on our products and services in which customers choose one of four levels of satisfaction in six survey items including quality, cost, and delivery. Survey results go to relevant

company divisions to be reflected in improved products and services.

In the fiscal year ended March 31, 2014, surveys were completed and sent in by 81 NTN customers worldwide.

Overall Assessment of Customer Satisfaction Surveys (Fiscal year ended March 31, 2014)



Strengthening Ties with Sales Agents around the World

Educating Sales Agents about NTN

NTN holds product briefings for its sales agents so that they can better convey information to NTN's end users. At various periodic training sessions for employees of sales agents, we deepen understanding of NTN products and technologies.

In the fiscal year ended March 31, 2014, we had large vans acting as mobile training units that toured bases in Japan and Korea, visiting sales agents to introduce aftermarket products and conduct demonstrations of maintenance and repair techniques.

In July 2013, we held our Domestic Distributor Association meeting in Japan with 61 sales agents. Besides honoring the top performing 24 sales agents, we held a product exhibit.

Information Exchange and Interaction at NTN Worldwide

In the fiscal year ended March 31, 2014, overseas group companies held gatherings for information exchange and interaction. An ASEAN-India sales agent meeting was held in April and an India sales agent meeting was held in February, each attended by 19 companies. In June, the 2nd Global Industrial Machinery/Aftermarket Conference was held, with representatives from Europe and the Americas, Asia, and China discussing marketing activities and NTN Corporation heads meeting with the management of three major sales agents from the Americas.

NTN (CHINA) Investment Corp. holds the Product Training School every year, and the four sessions in the fiscal year ended March 31, 2014 welcomed 87 members of 43 sales agents. Participants learned basic bearing knowledge and techniques such as how to mount and dismount bearings.

Based on fair and proper dealings, we strive to build a partnership with suppliers.



Suppliers meeting at IWATA WORKS

Procurement Policy

Selecting Partners in Line with Group Policy Building Partners Worldwide

Based on our Basic Procurement Policy, which we formulated with a view to fairness, equality, and global thinking, we have strived to select suppliers and build a relationship of trust with them. We have especially tried to build relationships with local overseas suppliers based on a philosophy of “on local site with local materials by local personnel.”*

In the fiscal year ended March 31, 2014, we continued our efforts from the previous year to cultivate multiple suppliers and establish suppliers adjacent to production bases. To spread and offset risk, we begin these efforts whenever new bases are established.

* “On local site with local materials by local personnel”: Establish a system in which NTN’s local employees manage business using locally sourced equipment and materials.

Basic Procurement Policy

- ① We stress quality, cost advantage, and on-time delivery from a global viewpoint, and we pursue stable procurement through prompt response to market changes.
- ② We abide by laws and ethics, and we promote fairness and equality in business.
- ③ Through procurement activities, we strive to conduct business in a manner that protects the environment and preserves resources.
- ④ We deepen understanding with suppliers, and we aim to create a partnership founded on trust that generates mutual prosperity.

Promotion of CSR Procurement

We go through several stages in choosing suppliers who are earnest in putting CSR into business action.

In the fiscal year ended March 31, 2014, we revised the basic contract, adding three clauses related to respect for human rights, rejection of relations with anti-social forces, and forbidding of bribes. We are also looking into methods for monitoring whether suppliers are abiding by our CSR Policy.

The U.S. Dodd-Frank Wall Street Reform and Consumer Protection Act has a Conflict Minerals Provision*. To comply with this, we have a database of the four minerals designated in the act. We also have a 24-7 reception system in Japan and other countries regarding our use of these minerals. As of the end of March 2014, we had received approximately 400 inquiries.

* Conflict Minerals Provision Act: Requires manufacturers to report and make public their use of four minerals (gold, tantalum, tin, and tungsten), as well as their derivatives, that are mined in the Democratic Republic of the Congo (DCR) and nine surrounding countries.

Conveying Policy through Briefings and Workshops

NTN holds suppliers meetings to explain NTN’s procurement policy and production volumes at production bases, as well as about how they can help in production activities and obtain ISO certification.

In the fiscal year ended March 31, 2014, we held two meetings attended by a total of 57 suppliers, who were asked to consider using new materials and new processes in the face of market competition. We also invited suppliers to join training workshops for NTN employees that were led by outside instructors.

Besides these examples of work-related information provision, we also took every opportunity possible for interaction with suppliers; for example, joining them in tree-planting activities at their sites in Japan.

Fair and Appropriate Business

Thorough Compliance with the Subcontract Act Self-Audits and Workshops at 17 Bases

In January 1997, NTN formulated the Self-Audit Manual for Subcontractors. NTN production bases conduct their own self-audits using this manual, and when necessary, NTN’s procurement division intervenes with periodic audits and guidance to ensure compliance with Japan’s Subcontract Act. Of NTN’s suppliers in Japan, 80% are subject to the Subcontract Act, so it is crucial that we ensure these suppliers are carrying out business dealings in a fair manner.

In the fiscal year ended March 31, 2014, self-audits were held at 17 bases in Japan (16 production bases, 1 research center). NTN’s procurement division intervened in all cases to ensure thoroughness of the audits. We will work to improve the compliance situation at bases that, for example, require a better understanding of the Subcontract Act or have failed to recognize its full importance.

We require all procurement staff to attend Subcontract Act workshops held by the Japan Fair Trade Commission as well as seminars held outside NTN. In addition, the procurement division held Subcontract Act training to give all factory staff a deeper understanding. In the fiscal year ended March 31, 2014, workshops were held at 17 bases. (See pages 34 to 38 for details on compliance education matters including the Subcontract Act.)

We respect diversity of employees and strive to build a safe and comfortable workplace.

Occupational Safety and Health

Building a Management System Based on OSHMS

We work to create safe work environments based on a “safety first” spirit that respects people. We have therefore created a safety and health management system based on the criteria of the Occupational Safety and Health Management System (OSHMS).

As of March 2014, a total of eight bases had been certified for OSHMS, and NTN KAMIINA CORP. began preparations for certification.

Occupational Safety and Health Based on 5 Themes

In the fiscal year ended March 31, 2014, we strove to improve occupational safety and health in five areas, with a special focus on eliminating workplace accidents at NTN subsidiaries. Unfortunately, there were 39 workplace accidents, four more than the previous year.

In the fiscal year ending March 31, 2015, we are striving to

step up occupational safety and health across the entire NTN Group. We will revise work manuals and have managers and supervisors conduct risk assessments at sites, and, for subsidiaries that request them, give on-site guidance and training sessions. Efforts will also continue in education related to occupational safety and health, and physical and mental health.

Building Systems that Support Mental Health Care

NTN holds mental health training sessions for managers and supervisors, while outside counselors offer counseling during regular medical check-ups.

Employees can also receive counseling through NTN’s in-house counseling service, called the “Oasis NTN” (held twice a month) and the “Mental and Physical Health Counseling Service” by phone or email.

Respecting Human Rights and Diversity

A Workplace Free of Discrimination

NTN Group strives to create a discrimination-free workplace where all human rights are respected.

At NTN sites and Group companies in Japan, we include human-rights education as part of training for new employees, supervisors, and managers. We place particular emphasis on measures against sexual harassment and power harassment, and we have ongoing education on these issues for new employees and newly appointed managers. We also participate in the activities of regional human rights organizations and take part in a variety of human rights exhibitions and seminars. We also have Helplines inside and outside the company that make it easy for employees and others to seek advice when they feel that someone’s human rights have been violated.

NTN Group companies overseas have also built systems that help them continue to respect human rights.

Promoting Diversity in the Workplace

Hiring Women, the Disabled, and Seniors

Women are making up an increasingly larger percentage of the university graduates hired by NTN. In the fiscal year ended March 31, 2014, women accounted for 16.9% of the NTN Group in Japan, up 2.1 points from the previous fiscal year. In April 2014, we launched the Diversity Team project, whose main goal is to give women a more active role. (See page 43 for details.)

We are also giving people with intellectual disabilities the chance to contribute to the company as much as anyone else. To this end we created “Dream Workshops” at IWATA WORKS, KUJAWA WORKS, and OKAYAMA WORKS, where 11 employees with intellectual disabilities work as of the fiscal year ended

Main Focuses and Activities in Fiscal Year Ended March 31, 2014	
1. Elimination of workplace accidents (thorough management of work conduct risks and skills)	
To improve hands-on safety education, more simulation devices were added at three works and newly installed at NTN HOUDATSU SHIMIZU CORP.	Head Office, subsidiaries
Safety supervisors at 4 NTN works and 3 subsidiaries conducted cross-inspections of occupational safety and health at each other’s sites and shared outstanding case studies.	Head Office, subsidiaries
Diagnoses were conducted at 8 of 17 subsidiaries. Based on the results, training was held twice at NTN MIE CORP.	Subsidiaries
Focused support was given to subsidiaries seen as operating at a relatively low level of safety (for 2 years).	Subsidiaries
2. Thorough education on safety and health	
Conducted training sessions related to laws and occupational safety and health.	Head Office
Provided occupational safety and health education to employees who are new to sites.	Head Office
Provided mental health education to managers and supervisors.	Head Office
Held back pain workshops; 45 participants.	Head Office
Risk assessment training was held, KUJAWA WORKS, and NTN MIE CORP.	Head Office, subsidiaries
3. Health promotion	
A public health nurse at the Head Office provided individual health guidance at all NTN Group sales bases (Head Office, branches, and sales offices).	Head Office, subsidiaries
4,325 employees underwent specific health checkups, and 402 received specific health guidance.	Head Office
4. Mental health activities	
Twice-monthly counseling service, Oasis NTN, was held.	Head Office
All employees underwent medical interviews to be checked for problems such as depression, panic disorder, and obsessive-compulsive disorder.	Head Office
Mental health checks were conducted on employees before being sent overseas.	Head Office
5. Raise occupational safety and health standard of NTN Group overall	
Focused on supporting NTN Group companies in Japan through measures mentioned above.	

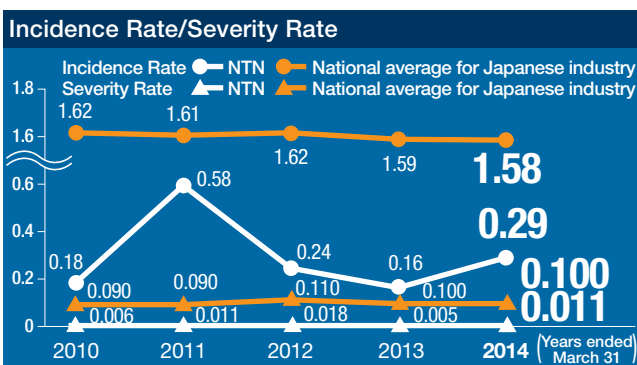



Training for new employees at a temple



Drawing done by children representing their favorite memories from their stay at Bear Kids Land daycare facility

March 31, 2014. In response to revisions to Japanese law in April 2013 raising the disabled persons employment rate for a company from 1.8% to 2.0%, we are working with special schools for the disabled, stepping up hiring over the Internet, and working to make our equipment and workplaces more disabled-friendly. As of March 2014, the entire Group employed 117 people (a 1.87% employment rate).

NTN Group in Japan has also striven to provide stable employment for seniors with a system under which retirees can be re-employed (system for re-employment of those in their early 60s). In the fiscal year ended March 31, 2014, there were 72 employees working under this system.

Helping Employees Continue Working While Raising Children

NTN Group strives to support employees in both their work and child-rearing.

In Japan, for example, there are numerous such programs, including the Mom-back system to rehire women who have temporarily retired to give birth or raise a child; Bear Kids Land, an in-company day-care center for employees; and the Child-raising Support Declaration system, under which employees write a child-raising plan and schedule that is shared with the entire workplace so that support is available. We also provide support beyond legal requirements with our system for reduced working hours for childcare, which now covers employees until their children have finished the second grade of elementary school.

Number of Employees Using Support Systems in Fiscal Year Ended March 31, 2014

Employees taking child-care leave	Employees using Bear Kids Land	Employees using Mom-back system
12 (including 2 men)	20	11

Human Resource Development and Evaluation

Global Human Resources Development

Of NTN's worldwide employees, 36% are in Japan and 64% are overseas, and our worldwide business expansion is set to continue. That's why we strive to develop the human resources who will run our production bases around the world.

We have a system under which Japanese NTN employees are sent to overseas bases for one year. We also have domestic and overseas training and scholarship programs for employees to acquire specialized skills and knowledge. NTN Group companies in Japan also host trainees from overseas companies on an ongoing basis.

In the fiscal year ended March 31, 2014, we hosted a total of 17 trainees from companies including Shanghai NTN Corp. and Nanjing NTN Corp. We also provided employees in Japan with internships and domestic study trips to boost their skills. Overseas NTN Group companies also each have its own training geared to its particular needs.

Promoting Self-Development and Higher Motivation

NTN Group does everything possible to boost employees' job motivation and provide opportunities for learning and development. For example, in the fiscal year ended March 31, 2012, NTN Group began QC activities in which employee teams work independently to boost product quality. The results of these efforts are presented at the annual Global QC Circle Convention.

In the fiscal year ended March 31, 2014, we sought to boost young employees' motivation through activities such as training at temples and a company volunteer effort in which young employees went to help out in areas stricken by the March 2011 earthquake and tsunami. (See page 49 for details.) Employees also strive to boost their foreign language skills through e-learning and correspondence courses.

Employment, Working Conditions, Employee Evaluation

NTN strives to hire and treat employees as well as the company's management situation allows. For example, we require that all employees join the NTN labor union so that they can have the right to organize.

In evaluating our employees, all are subject to a uniform evaluation standard that operates fairly regardless of employee gender.

Salary is composed of a base salary combining age consideration and job ability, as well as various allowances.

The job ability portion of salary is based on an employee evaluation undertaken by multiple managers, each with a unique perspective on the individual being evaluated.

Rewards for Employee Inventions

To reward our employees' inventions, we have established a Patent Management Rule and a Patent Reward Rule and we have clarified how patent rights are attributed and how the value of the award is calculated. Rewards are also made for foreign patents and for know-how and inventions considered to be trade secrets. There is no upper limit to actual awards. In the fiscal year ended March 31, 2014, we pursued an intellectual property strategy linked directly to business strategy and R&D strategy with the goal of boosting our competitiveness in key product areas. As a result, 380 employees (cumulative) were rewarded for obtaining rights for 160 patents, 43 more than the previous year.

We strive to contribute to society as we conduct ongoing activities that help local communities.

NTN Group Social Contribution Activities

Contributing to Communities as a Good Corporate Citizen

The NTN Group's CSR Policy states that we shall do all we can to interact with and contribute to local communities.

Based on the CSR Policy, business bases and Group companies around the world plan and implement a range of activities that include disaster recovery support, international exchange, internship hosting, participation in local events, and promotion of culture and sports.

Young Employees Assist in Post-Disaster Reconstruction Efforts (NTN Corporation)

In September 2013, 33 employees in their third year at NTN Corporation volunteered for support activities in areas stricken by the March 2011 earthquake and tsunami.

Realized with support from the NPO Ishinomaki Revival Support Network, this activity was aimed at having participants think about how to best cooperate with others and interpret their feelings, and to provide them with an opportunity to reevaluate themselves. Participants worked on reconstruction projects while seeing what has been accomplished so far and what still needs to be done.

After the three-day support activities, participants commented on how shocked they were at the extent of the damage and at the slow pace of reconstruction, as well as on how important an opportunity this was to understand other people's feelings.



Making a float to be used for oyster cultivation



Cleaning air conditioner filters at a temporary housing complex

Taking Part in Sports Events as Members of the Community (NTN-SNR, NTN NEI)

NTN bases around the world take part in various events held in their vicinity with the goal of promoting local education, art, and sports.

In the fiscal year ended March 31, 2014, NTN-SNR ROULEMENTS (NTN-SNR) sponsored the Lake Annecy Marathon in Annecy, France, presenting souvenirs to the runners and entering 12 of its own employees in the race.

NTN-SNR also sponsors other sports events in its community.

In India, a number of employees of NTN NEI Manufacturing India Private LTD. (NTN NEI) were on a cricket team taking part in a local cricket tournament. Their team was victorious and helped make the event a resounding success.



The Lake Annecy Marathon



Cricket tournament in the State of Haryana, India

Participation in Blood Donor Clinic (Shanghai NTN Corp., NTN-BOWER CORP., NTN NOTO CORP., others)

NTN Group companies in Japan and overseas take part in blood donor clinics sponsored by the Red Cross and other organizations.

In the fiscal year ended March 31, 2014, a municipal blood donor organization operated a blood donor clinic at Shanghai NTN Corp. (Shanghai NTN), with 105 NTN employees donating blood. Employees at NTN bases in Japan, the U.S.A., and other countries also took part in blood donor clinics in their areas.



Blood donor clinic at Shanghai NTN



Blood donor clinic at NTN-BOWER CORP.

Based on the NTN Group's Environmental Policy, we manage our environmental activities, including those aimed at external certification.

Environmental Management System

Management System Based on Our Group Environmental Policy

Building a Management System Based on NTN Environmental Policy

Based on the NTN Group's Environmental Policy, the purpose of which is to reduce environmental impact and ensure our company's continuous development, we have built an environmental management system centered around the Company-wide Environmental Management Committee. We also create and revise rules and manuals when necessary as part of ongoing improvement efforts.

ISO 14001 Certification at 24 Bases in Japan and 16 Overseas

NTN is obtaining ISO 14001 certification in Japan under multi-site certification so that it can build an environmental management system consistent over all bases.

In September 2013, NTN NOTO Corp. was certified, and as of the fiscal year ended March 31, 2014, 24 of our 25 bases had been certified. And 16 of 18 NTN bases outside Japan have been certified. NTN makes it a rule to have all new bases certified within three years of the startup of operations.

Below is the certification schedule starting in April 2014.

Operating sites expected to be ISO 14001 certified

Region	Operating site	Date of certification	
		Year	Month
Japan	NTN AKAIWA CORP.	2014	9
China	NTN-LYC (Luoyang) Bearing Corp.	2014	12
Brazil	NTN Driveshaft do Brasil	2015	11

ISO 14001 management system certificate and appendix



Operating Sites with ISO 14001 Certification

Region	Operating site		Date of certification		Registration	
	Company	Plant	Year	Month	Registration No.	Registration body
Japan	Multi-site certification		1999	11	JSAE176	JSA
	(Operating sites included) Head Office, KUWANA WORKS, IWATA WORKS, OKAYAMA WORKS, NAGANO WORKS, NTN KONGO CORP., NTN ENGINEERING PLASTICS CORP., NTN POWDER METAL CORP., NTN MIKUMO CORP., NTN CASTING CORP., NTN KINAN CORP., HIKARI SEIKI INDUSTRY CO., LTD., NTN MIE CORP., NTN OMAEZAKI CORP., NTN FUKUROI CORP., ADVANCED TECHNOLOGY R&D CENTER, NTN KAMIINA CORP., NTN BIZEN CORP., NTN HOUDATSU SHIMIZU CORP., NTN HAKUI CORP., NTN SHIKA CORP., NTN NOTO CORP.					
	NIPPON KAGAKU YAKIN CO., LTD.		2000	8	JQAEM0956	JQA
	NTN TADO CORP.		2005	3	JSAE1058	JSA
U.S.A.	AMERICAN NTN BEARING MFG. CORP.	Elgin Plant	2000	6	111994	LRQA
		Schiller Park Plant	2000	9	112115	LRQA
	NTN-BOWER CORP.	Macomb Plant	2000	6	111998	LRQA
		Hamilton Plant	2000	6	111999	LRQA
	NTN DRIVESHAFT, INC.		1999	12	A8478	UL
	NTN USA CORP. Head Office		2000	4	0112005	LRQA
Canada	NTN BEARING CORP. OF CANADA LTD.		1999	7	287	KPMG
	NTN Kugellagerfabrik (Deutschland) G.m.b.H		1999	6	201167-2	LRQA
	NTN TRANSMISSIONS EUROPE		2003	1	19479	AFAG
France	NTN-SNR ROULEMENTS*		2009	1	0448-4	UTAC
	NTN MANUFACTURING (THAILAND) CO., LTD.		2003	3	31634	TÜV
Thailand	Guangzhou NTN-Yulon Drivetrain Co., Ltd.		2005	4	104043247	TÜV
	Shanghai NTN Corp.		2005	7	CH05/0489	SGS
China	NTN NEI Manufacturing India Private LTD.		2011	6	104071903	TÜV

*Multi-site certification

Environmental Policy

Harmony with the global environment is our most important issue and we will continuously strive to contribute to the harmonious development of society and work to reduce the impact of our corporate activities on the environment.

1. Development and sales of environmentally-friendly products

- NTN will contribute to world-wide energy conservation by developing and providing eco-products using tribological technologies and high precision processing technologies.

2. Reduction of environmental impact

- NTN will work to prevent global warming by improving energy efficiency activities throughout the business process, from procurement of materials and parts, through to manufacture, distribution and sales.
- NTN will strive to reduce waste by paying heed to efficient use of raw materials, and thorough application of the 3Rs (reduce, reuse, recycle).
- NTN will avert environmental pollution by rigorous management of substances having an environmental impact that are used in products or processes, and by active substitution of chemical substances suspected of having harmful effects.

3. Observance of laws and regulations and implementation of thorough environmental management systems

- In addition to observing laws, regulations and ordinances, NTN will actively seek to comply with requests from regional communities and customers by imposing tighter self-determined standards and internal rules, and keeping to them.
- NTN will establish an environmental management organization and operational methods, and will conduct environmental audits to maintain and improve corporate environmental management systems. We will also advance communication with society at large by publishing information about our environmental initiatives.
- NTN will conduct environmental education. NTN will promote improved awareness of this Environmental Policy and environmental protection to all persons working on behalf of the NTN Group.

4. Activities to contribute to society and protect the natural environment

- By actively participating in regional social contribution activities and natural environmental protection activities, NTN will interact with the immediate community, aiming to develop together with the local region.

Environmental Impact of Business Activities

Reducing Environmental Impact in All Production Processes

The NTN Group strives to reduce environmental impact in all processes, from forging to assembly. To this end, we try to get an overall picture of the amount of raw materials, energy, and water we use (the input) and the products, CO₂, waste, and wastewater that are generated (the output).

and wastewater that are generated (the output).

In the fiscal year ended March 31, 2014, CO₂ emissions increased due to factors including an unusually hot summer. However, we managed to decrease landfill waste by about half. This was due to our recycling of incinerated ash, which was previously landfilled, into roadbed material and other useful material, and the recycling of sludge from grinding.

At operating site in Japan

Environmental Impact for Each Process

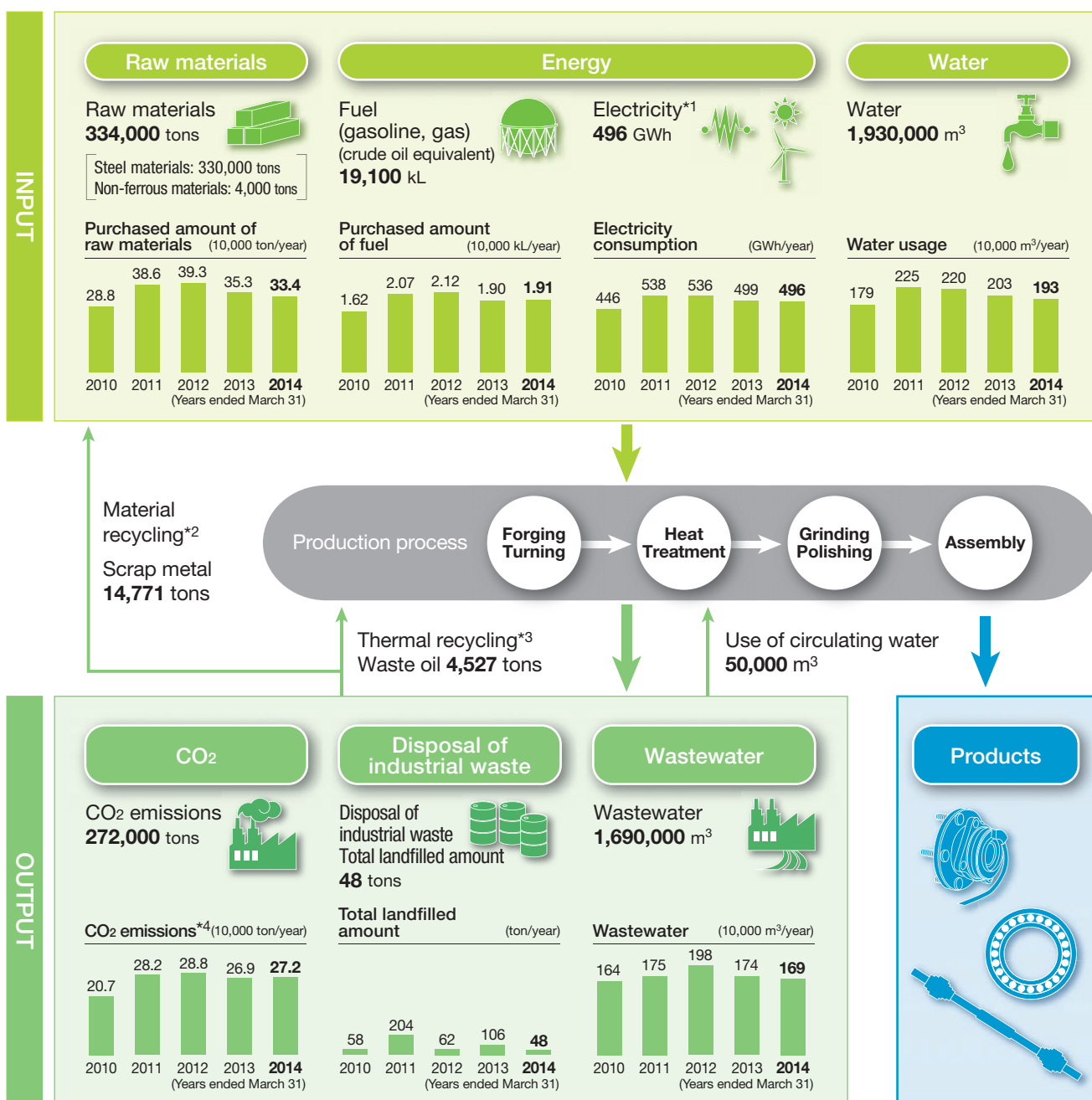

*1 Electricity: Include amount of renewable energy used *2 Material recycling: To recycle for use as a raw material *3 Thermal recycling: To recycle for use as fuel
*4 CO₂ emissions: The value calculated between the fiscal year ended March 31, 2010 and the fiscal year ended March 31, 2014, based on the fixity coefficient (0.381) introduced in the fiscal year ended March 31, 2013.



High-efficiency air conditioning at NTN POWDER METAL CORP.



EneMeter at the ADVANCED TECHNOLOGY R&D CENTER

Environmental Accounting

Large Investments in Research and Development

The NTN Group uses environmental accounting to quantitatively assess its environmental protection activities.

Environmental preservation costs in the fiscal year ended March 31, 2014 were approximately 4,726 million yen, up 19% from the previous fiscal year. This consisted of 1,182 million yen in environment-related equipment investment, up 20%, and related costs of 3,544 million yen, up 18%. Contributing to this overall increase was low environment-related equipment investment the previous year coupled with aggressive investment in areas such as environment-protection-related investment (EV-related business, for example) and renewable energy. There were also costs for items like energy-efficient equipment and waste recycling.

The economic benefit of environmental protection activities was 869 million yen, due partly to making use of waste products such as metal sludge. As for impact on environmental preservation, CO₂ emissions were 272,000 tons. Despite the effects of an unusually hot summer and a change in the make-up of our production items, we strove to reduce CO₂ emissions and were able to limit the CO₂ emissions increase over the previous year to just 3,000 tons. For example, we installed an EneMeter at the Advanced Technology R&D Center to show the amount of electricity being used. As well, at NTN KINAN CORP., we installed an air-handling unit, which allowed us to remove air conditioning units. (See page 56 for details.)

At operating site in Japan

Environmental Preservation Costs				(Millions of yen/year)	
Classification		Equipment investment		Amount	
		Costs	Details	Costs	Details
Work areas Internal costs	Pollution prevention costs	8	Environmental equipment (dust collectors, particulate smoke removal devices, and wastewater treatment equipment)	161	Inspection and management of environmental equipment (dust collectors and wastewater treatment equipment)
	Expenses to preserve the global environment	44	Energy-conserving equipment (upgrading of equipment including compressors, lighting, and air conditioning)	154	Costs of switching to energy-saving equipment
	Resource recycling expenses	1		566	Cost of recycling and waste reduction measures, cost of processing regular and industrial waste
Upstream / downstream costs		0		2	Costs of analysis related to green procurement
Costs of management activities		3		374	Labor costs related to the EMS and information disclosure (advertising and NTN reports) and the greening and beautification of company grounds
R&D costs		1,125	R&D equipment related to environmental preservation	2,267	R&D costs related to environmental preservation
Costs of social activities		0		15	Greening and beautification outside the company
Environmental remediation expenses		0		5	Cost of soil sampling
Total		1,182		3,544	Grand total
Reference: Total for fiscal year ended March 31, 2013		985		2,995	4,726
					3,980

Impact on Environmental Preservation		
Indicator	Fiscal year ended March 31, 2014	Fiscal year ended March 31, 2013
Total CO ₂ emissions	272,000 tons	269,000 tons
Reduction of waste	Recycle rate 99.8%	99.8%

Financial Effect of Environmental Preservation Activities			(Millions of yen/year)
Item	Amount	Details	
Global environment preservation expenses, effects	97	Energy-conserving effects, etc. of compressors and lighting	
Resource recycling expenses, effects	772	Profit from saleable materials such as metallic sludge	
Total	869		
Reference: Total for fiscal year ended March 31, 2013	683		

Environmental Targets and Results for the Fiscal Year Ended March 31, 2014

20 of 28 Targets Achieved

Every year, NTN sets and works towards the achievement of targets in line with four items of our Group Environmental Policy.

In the fiscal year ended March 31, 2014, areas of focus

included reducing global warming impact, stepping up the 3Rs (reduce, reuse, recycle), and managing and reducing environmentally hazardous substances. Although we achieved targets for CO₂ emissions overseas, we failed to do so for reducing the CO₂ emissions rate in Japan and overseas.

We were, however, able to achieve targets in Japan for raising the recycling rate and reducing water used per unit.

Company-Wide Environmental Targets and Results for the Fiscal Year Ended March 31, 2014

NTN Group Environmental Policy					
Environmental Purpose	Environmental Targets		Results	Evaluation	
1. Development and sales of environmentally-friendly products					
(1) Development of energy-efficient products	Develop environmentally friendly products to meet needs of expanding new energy and greater number of electric cars		R&D in progress in engineering and research divisions	☺	
	Formulate and implement assessment and judgment criteria for environmental efficiency in developing new products		Preparing to implement	☺	
2. Reduction of environmental impact					
(1) Prevention of global warming	Wherever possible, save energy and cut peak energy use		Underway at sites	☺	
	Make existing manufacturing equipment more energy efficient		Mainly young engineers working on this under guidance of Production Strategy & Control Dept.	☺	
	Publish and use case studies		Currently compiling case studies	☺	
	Reduce CO ₂ emissions	Domestic	252,000 tons/year or less	272,000 tons/year	☹
		Overseas	340,000 tons/year or less	308,000 tons/year	☺
	Reduction in CO ₂ emissions rate	Domestic	Achieve a 20.3% improvement in CO ₂ emissions rate over the fiscal year ended March 31, 1998 -20.3%	-16.6%	☹
Overseas		Achieve a 10% improvement in CO ₂ emissions rate over the fiscal year ended March 31, 2007 -10%	-8.1%	☹	
(2) Reduce, reuse, and recycle	Raise the recycling rate	Domestic	99.8% or more	99.8%	☺
		Overseas	98% or more	96.5%	☹
(3) Preserve resources	Reduction in waste per unit of production output	Domestic	Reduce waste generation rate by 1% over the fiscal year ended March 31, 2011 -1%	+1%	☹
	Reduction in paper purchased per unit of production output	Domestic	Increase by 5% paper consumption over the fiscal year ended March 31, 2011 +5%	+19%	☹
	Reduction in water used per unit of production output	Domestic	Reduce by 6% water usage rate over the fiscal year ended March 31, 2011 -6%	-7%	☺
(4) Management and reduction of environmentally hazardous substances	Reduction in use of Styrofoam	Domestic	Reduce Styrofoam usage by 99% over the fiscal year ended March 31, 2000 -99%	-99.5%	☺
	Begin manufacturing using phthalate esters substitutes		Switching to substitutes began on April 1	☺	
	Establish technology for using substitutes for BNST and dibutyltin		BNST: Currently switching from continuously demanded item Dibutyltin: Substitutes exist	☺	
	Reduce PRTR-designated substances	Domestic	Reduce N,N-Dicyclohexylamine by 85% over fiscal year ended March 31, 2011 -85%	-82%	☹
	3. Observance of laws and regulations and implementation of thorough environmental management systems				
(1) Compliance with environmental laws	Create measures to prevent leak accidents, carry out improved and full-scale emergency drills		Completed at all sites	☺	
	Continue strict management of poisonous materials		Strict management continuing	☺	
	Start soil purification at former site of TAKARAZUKA Works		Under discussion with local residents	☺	
(2) Improvement of environmental management systems	ISO 14000 certification	Certification at NTN NOTO CORP.		Certification complete	☺
		Prepare for certification at NTN AKAIWA CORP.		Currently preparing	☺
	ISO 50001 certification	Trial introduction of energy review and other methods to confirm effectiveness		Switching in order to comply with Law Concerning the Rational Use of Energy	—
	Promote green procurement	Certify the environmental management systems of at least 95% of key suppliers		95%	☺
		Thoroughly assess potential new suppliers on their green procurement paperwork		Underway as necessary	☺
Zero complaints of environmentally hazardous substances		No complaints	☺		
4. Activities to contribute to society and protect the natural environment					
(1) Protecting Biodiversity	NTN Kigyo no Mori and other greening and environmental protection activities		In progress in various regions	☺	

☺ Achieved ☹ Not achieved

Environmental Targets for the Fiscal Years Ending March 31, 2015

NTN Environmental Action Policy for the Fiscal Year Ending March 31, 2015

- | | |
|---|--|
| 1. Development and sales of environmentally-friendly products | (1) Development of energy-efficient products |
| 2. Reduction of environmental impact | (1) Prevention of global warming
(2) Reduce, reuse, and recycle
(3) Preserve resources
(4) Management and reduction of environmentally hazardous substances |
| 3. Observance of laws and regulations and implementation of thorough environmental management systems | (1) Compliance with environmental laws
(2) Improvement of environmental management systems |
| 4. Activities to contribute to society and protect the natural environment | (1) Protecting biodiversity |

Company-Wide Environmental Targets for the Fiscal Year Ending March 31, 2015 Items not labeled "Domestic" or "Overseas" are NTN targets.

NTN Group Environmental Policy			
Environmental Purpose	Environmental Targets		
1. Development and sales of environmentally-friendly products			
(1) Development of energy-efficient products	Develop environmentally friendly products to meet needs of expanding new energy and greater number of electric cars		
	Begin assessment of environmental efficiency in new product development		
2. Reduction of environmental impact			
(1) Prevention of global warming	Wherever possible, save energy and cut peak energy use		
	Improve energy efficiency of existing equipment by utilizing management standards		
	Reduce CO ₂ emissions rate in production restructuring		
	Reduce CO ₂ emissions	Domestic	268,000 tons/year or less
		Overseas	320,000 tons/year or less
Reduction in CO ₂ emissions rate	Domestic	Achieve a 17.8% improvement in CO ₂ emissions rate over the fiscal year ended March 31, 1998 -17.8%	
	Overseas	Achieve a 10% improvement in CO ₂ emissions rate over the fiscal year ended March 31, 2007 -10%	
(2) Reduce, reuse, and recycle	Raise the recycling rate	Domestic	99.8% or more
		Overseas	98% or more
Reduction in waste per unit of production output	Domestic	Reduce waste generation rate by 0.8% over the fiscal year ended March 31, 2011 -0.8%	
(3) Preserve resources	Reduction in paper purchased per unit of production output	Domestic	Increase by 10% paper consumption over the fiscal year ended March 31, 2011 +10%
	Reduction in water used per unit of production output	Domestic	Reduce by 10% water usage rate over the fiscal year ended March 31, 2011 -10%
	Reduction in use of Styrofoam	Domestic	Reduce Styrofoam usage by 99% over the fiscal year ended March 31, 2000 -99%
(4) Management and reduction of environmentally hazardous substances	Manufacturing using phthalate esters substitutes in progress		
	BNST replacement in progress		
	Reduce PRTR-designated substances	Domestic	Completely eliminate N,N-Dicyclohexylamine
3. Observance of laws and regulations and implementation of thorough environmental management systems			
(1) Compliance with environmental laws	Continue to create measures to prevent leak accidents and carry out improved and full-scale emergency drills		
	Continue strict management of poisonous materials		
	Start soil purification and process management at former site of TAKARAZUKA WORKS		
(2) Improvement of environmental management systems	ISO 14000 certification	Certification for NTN AKAIWA CORP. and NTN-LYC (Luoyang) Bearing Corp.	
	Energy management	Strengthen energy management system to comply with the Revised Rationalization in Energy Use Law	
	Certify the environmental management systems of at least 95% of key suppliers		
	Promote green procurement	Clarification of responsibilities for green procurement in each division	
Zero complaints of environmentally hazardous substances			
4. Activities to contribute to society and protect the natural environment			
(1) Protecting Biodiversity	NTN Kigyo no Mori and other greening and environmental protection activities		

Training related to Revised Rationalization in Energy Use Law



NTN's EV used as a pace car at an ekiden in Mie Prefecture

Environmental Audits

Two Types Internal Audits Conducted

The NTN Group in Japan has internal site audits (once a year), which are conducted by each site's internal auditors, and cross-audits (every three years), which are conducted between operating sites. Also part of improving the level of environmental management systems are external audits by ISO certification institutes.

In the fiscal year ended March 31, 2014, internal audits were held at all bases and cross-audits were held at eight bases. ISO audits were held at seven bases in July 2013, and since there were no violations of laws or internal NTN regulations, these sites kept their multi-site certification designation. Although there was one item cited, measures had already been put in place to rectify it in the fiscal year ended March 31, 2014. NTN FUKUROI CORP. underwent an inspection by the Agency for Natural Resources and Energy as a designated energy management factory. It was found to be conducting outstanding efforts in complying with relevant standards of the Law Concerning the Rational Use of Energy.

Number of Internal Environmental Auditors Reaches 278

The NTN Group in Japan held its first training session to increase the number of internal environmental auditors.

In the fiscal year ended March 31, 2014, internal environmental auditor training was held in November 2013 and led by a top instructor from L.M.J. Japan, an institute that trains ISO auditors. The training was attended by 23 members of 12 bases, including NTN AKAIWA CORP., which is aiming for ISO 14001 certification. Participants got an overview of ISO, acquired the skills needed by an internal environmental auditor, learned points to keep in mind in conducting audits, and used case studies to learn practical auditing skills. This latest training brought the number of NTN internal environmental auditors to 278.

Response to Laws

Training to Comply with Revised Rationalization in Energy Use Law

The NTN Group keeps abreast of the latest environmental laws and regulations and keeps relevant employees up to date with the necessary information.

In January 2014, we held training to prepare for the April 2014 enactment of the Revised Rationalization in Energy Use Law. People in charge of energy management and other related employees joined as an outside expert spoke about how to comply with the revised law.

Environmental Education

Education Geared to Workplace Needs

The NTN Group strives to raise environmental awareness by holding environmental education for all levels of employees at the head office, business sites, and group companies, gearing sessions to particular characteristics of each location.

TOPICS

Environmental Education for Suppliers (NTN ENGINEERING PLASTICS CORP.)

Reducing environmental impact requires not only the efforts of NTN but also the efforts of all those involved in our business.

In November 2013, we invited our suppliers to a quality conference, where we explained what both NTN and society as a whole are doing to protect the environment, and urged suppliers to cooperate in developing and providing products with low environmental impact.



Environmental Communication

Promoting NTN's EV Technologies

NTN takes part in environment- and technology-related trade fairs in order to promote its products and technologies that contribute to protecting the environment.

In the fiscal year ended March 31, 2014, a microcompact electric vehicle (EV) using NTN's In-wheel Motor System was unveiled at the "Mt. Fuji EV Festa." This is the first in-wheel motor vehicle in Japan to acquire registration of microcompact mobility*. NTN also cooperated in a demonstration project of this microcompact EV in France. The EV and its components were also shown at the "Shanghai Motor Show" and at the "Mie Environment Fair 2013" sponsored by the Mie prefectural government. In other promotional use of this EV, NTN provided it for use as a lead vehicle and publicity vehicle at marathons and ekidens held in Wakayama Prefecture and Mie Prefecture.

NTN once again joined the "Leading Industry Exhibition Mie" as last year, displaying bearings for wind turbines and the Condition Monitoring System (CMS) for wind turbines, and promoting environmental products and technologies for industrial machinery.

* Microcompact mobility: For vehicles made for one or two persons; managed by Japan's Ministry of Land, Infrastructure, Transport and Tourism.

We are Reducing CO₂ Emissions at All NTN Production Bases Around the World.

Reduction of CO₂ Emissions

CO₂ Reduction a Key Environmental Protection Theme

Since April 2013, the NTN Group has positioned the reduction of CO₂ emissions as a key environmental protection theme based on new environmental target. In the fiscal year ended March 31, 2013, we revised our calculation method for CO₂ emissions, using a fixity coefficient (0.381) instead of a variation coefficient for each power supplier. This has allowed us to more accurately compare how effective our activities are from year to year.

Efforts in Japan

CO₂ Emissions Up 1% Over the Fiscal Year Ended March 31, 2013

For the fiscal year ended March 31, 2014, we set targets of CO₂ emissions of 252,000 tons and CO₂ emissions rate of 0.69 t-CO₂ per million yen. However, despite efforts to save energy, including the installation of LED lighting, upgrading of equipment including high-efficiency air conditioning, and monitors showing the amount of electricity being used, we fell short of both targets, with CO₂ emissions of 272,000 tons and CO₂ emissions rate of 0.73 t-CO₂ per million yen. Main contributing factors were the unusually hot summer and a change in the make-up of our production items.

For the fiscal year ending March 31, 2015, we are working towards targets of CO₂ emissions of 268,000 tons and CO₂ emissions rate of 0.72 t-CO₂ per million yen.

Energy Savings and Equipment Investment at NTN Sites

In the fiscal year ended March 31, 2014, we launched a team dedicated to reducing energy consumption of production equipment. Composed of 48 young engineers from 10 NTN Group sites in Japan, the team's purpose is to reduce energy consumption while giving the engineers valuable experience, and it spent the past year improving the energy efficiency of NTN production equipment.

In February 2014, a meeting was held to share the results and progress of the team's efforts. Besides reports on the

Results of Efforts in the Fiscal Year Ended March 31, 2014 (NTN Group in Japan)

CO₂ emissions
272,000
tons/year

CO₂ emissions rate
0.73
t-CO₂ per million yen

LED floodlight at NTN NOTO CORP.

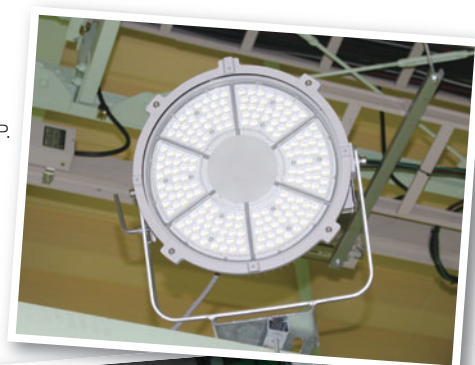

Air handling unit at NTN KINAN CORP.

implementation of energy-saving measures including insulation for machinery and stoppage of conveyor belts not being used, participants spoke about how their efforts gave them a better understanding of electricity use through actually measuring electricity and adjusting equipment and revising programs. Team members given certification with designations such as electricity management engineers and energy managers.

There were other efforts as well. Numerous sites installed LED lighting. NTN KINAN CORP. installed an air-handling unit and removed its air conditioning units. An air handling unit uses water to cool the air, which reduces electricity consumption.

CO₂ Emissions*¹ and CO₂ Emissions Rate*² (NTN Group in Japan)

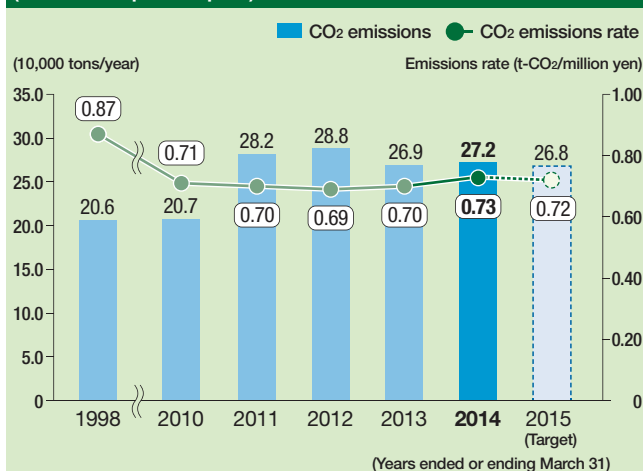

*1 CO₂ emissions: Based on fixity coefficient (0.381)

*2 CO₂ emissions rate: Per unit of production output



NTN-SNR's car-pooling website



NTN-SNR encourages employees to car-pool



Efforts Overseas

CO₂ Emission Reduction Targets Achieved

For the fiscal year ended March 31, 2014, we set targets of CO₂ emissions of 340,000 tons and CO₂ emissions rate of 1.11 t-CO₂ per million yen. We achieved the CO₂ emissions target with a figure of 308,000 tons, but failed to do so for CO₂ emissions rate, which was of 1.13 t-CO₂ per million yen. The main reason was a change in the make-up of production items at a number of sites.

The target for the fiscal year ending March 31, 2015 is total CO₂ emissions of 320,000 tons and CO₂ emissions rate of 1.11 t-CO₂ per million yen.

The company has also begun encouraging car-pooling for employees driving to work. The company started a dedicated website in February 2014 through which drivers and passengers can match their commuter routes for car-pooling. As of March 2014, 69 cars were registered and had driven a total of 950 kilometers, which has reduced the company's CO₂ emissions from commuter cars by 14 tons.

Results of Efforts in the Fiscal Year Ended March 31, 2014 (NTN Group Overseas)

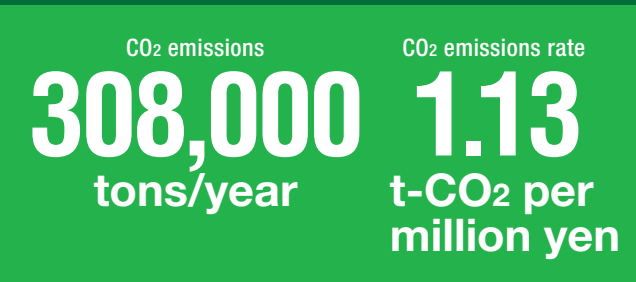

Reducing CO₂ Emissions During Distribution

Pursuing Modal Shifts

CO₂ Emissions Reduced by 1.7% Over the Fiscal Year Ended March 31, 2013

The NTN Group strives to reduce CO₂ emissions and costs through modal shifts: more environmentally friendly forms of transport.

In November 2012, we began switching deliveries between KUWANA WORKS and NTN NOTO CORP. from truck to rail. In the fiscal year ended March 31, 2014, this reduced CO₂ emissions by 42 tons and crude oil use by 15.7 kiloliters.

CO₂ Emissions*1 and CO₂ Emissions Rate*2 (NTN Group Overseas)

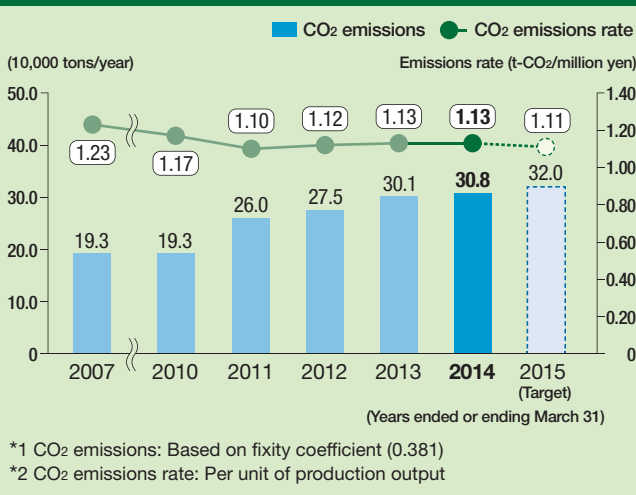

*1 CO₂ emissions: Based on fixity coefficient (0.381)
 *2 CO₂ emissions rate: Per unit of production output

Making Container Transport More Efficient

We are striving to make truck transport more efficient by reducing the cargo volume and shortening the delivery distances.

In February 2013, the outgoing port for products from Hakui County, Ishikawa Prefecture and bound for Germany was changed from Nagoya to Kanazawa. This shortened the distance trucks had to travel and as a result in the fiscal year ended March 31, 2014, we reduced CO₂ emissions by 23 tons and light diesel consumption by 8 kiloliters.

In September 2013, for shipments from Okayama to Kobe to France, we achieved savings by using the empty containers at the port that other companies had used to import goods.

In the fiscal year ended March 31, 2014, we shipped a total weight of 1,088 tons using 122 containers (20-foot size). We plan to expand this effort.



Shipping goods from Kanazawa port to Germany

Upgrading to Energy-Efficient Equipment to Reduce Electricity Consumption and CO₂ Emissions

NTN-SNR ROULEMENTS (NTN-SNR) formulated an eco-energy plan two years ago and has since then been systematically conducting energy-efficiency activities.

In the fiscal year ended March 31, 2014, the company converted its compressors and other equipment to energy-efficient models. This is expected to reduce annual CO₂ emissions by 28 tons.

We are Making Efficient Use of Raw Materials and Reducing Waste in All Production and Distribution Processes.

Device for recovering water-soluble coolant in France

Zero Emissions

Raising the Recycling Rate at Production Bases

The NTN Group defines zero emissions as landfill waste constituting 0.5% or less of total waste generated (a recycling rate of at least 99.5%) and we work towards this by raising the recycling rate.

Efforts in Japan

Reducing Waste and Increasing Recycling at NTN Bases

In the fiscal year ended March 31, 2014, the NTN Group in Japan strove to maintain a recycle rate of at least 99.8%.

At NTN MIE CORP., incinerated ash that was previously landfilled is now being melted and recycled as roadbed material and civil engineering raw material. This has reduced landfill waste by approximately 70%. NTN NOTO CORP. has been recycling sludge from grinding and as a result improved its recycling rate by 2.2 points.

These efforts allowed us to achieve our recycling ratio target, which we plan to maintain in the fiscal year ending March 31, 2015.



Incinerated ash is recycled into roadbed material like this



Efforts Overseas

Recovery and Reuse of Water-Soluble Coolant Begins in France

NTN TRANSMISSIONS EUROPE had previously been disposing of industrial waste consisting of metal chips generated in the lathing process and the water-soluble coolant (cutting fluid) mixed in with this. To reduce this waste and make effective use of material, the company installed a device that recovers the water-soluble coolant from the carts that this industrial waste mix is placed in.

This has allowed the company to reuse water-soluble coolant and as a whole consume 50% less of it.

Results of Efforts in the Fiscal Year Ended March 31, 2014 (NTN Group in Japan)

Recycling rate
99.8%

Recycling Rate and Waste Per Unit of Production Output (NTN Group in Japan)

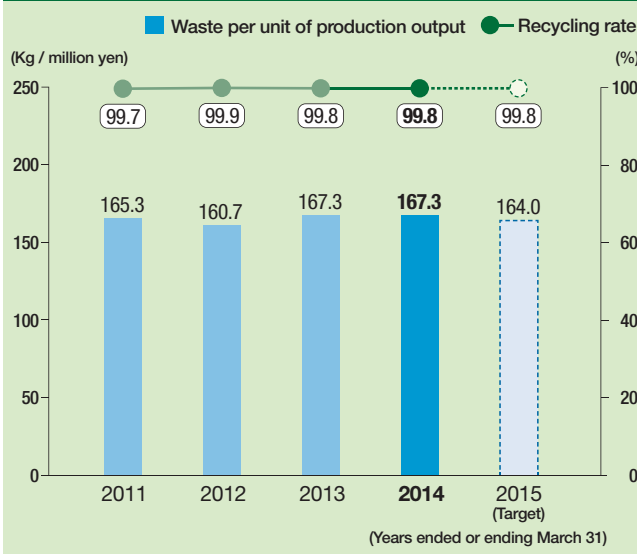

Reducing Waste During Distribution

Using Returnable Boxes

The NTN Group strives to reduce the amount of waste from packaging resulting from the shipping of raw materials and products.

In October 2013, we began using returnable plastic boxes as product packaging for customers in the Kanto region who we deliver products to on a regular basis. This has not only reduced the amount of cardboard used, but thanks to modifying the shapes of the boxes, we were able to eliminate the bands that are used to prevent product cases from being crushed during delivery.

Returnable plastic boxes used in the Kanto region



With lid



Without lid

We are Managing and Reducing Environmentally Hazardous Substances While Complying with Worldwide Laws and Regulations.

Management of Environmentally Hazardous and Harmful Substances

Response to Environmental Regulations

The NTN Group complies with chemical substance restrictions around the world by keeping a close watch on changing restrictions and constantly testing for what substances are contained in the raw materials, parts, and materials it procures. We strive to manage and reduce the amount of environmentally hazardous and harmful substances we use.

Meeting REACH and CLP Requirements Switch Begun from Rubber Containing Phthalate Esters

In Europe, in line with the REACH (Registration, Evaluation, Authorisation and Restriction of Chemicals) regulation and the CLP (Classification, Labeling, and Packaging) regulation, we check whether our products contain substances designated by these regulations and report to the relevant authorities and to our customers. We also develop technologies for using substitutes for the designated substances.

Under the REACH regulation, there are deadlines for switching to substitutes for each designated substance. The deadline for the elimination of phthalate esters, commonly used in rubber products, is February 2015. To meet this deadline, in the fiscal year ended March 31, 2014 we began procuring rubber items from our suppliers that do not contain phthalate esters.

Air Pollution Control Law Survey of Emissions from Heating Furnaces

In July 2013, KUWANA WORKS tested emissions at its heat-treatment plant in accordance with Japan's Air Pollution Control Law. The plant operates a heating furnace used for product heat treatment and other processes, and the furnace was tested for emission levels of sulfur oxide, dust, and nitrogen oxide. Tests confirmed that levels of all substances were within the limits of environmental laws and in-house standards.

Law Concerning Special Measures against PCB Waste 27 High-Voltage Capacitors Disposed of

In accordance with the Law Concerning Special Measures against PCB Waste, the NTN Group in Japan systematically disposes of PCB. In the fiscal year ended March 31, 2014, IWATA WORKS disposed of 27 high-voltage capacitors containing PCB.



Testing emissions at KUWANA WORKS

Management of Other Environmentally Hazardous Substances

Working towards Elimination of N,N-Dicyclohexylamine

The NTN Group in Japan continuously and voluntarily works to reduce the amount of chemicals it handles that are designated under the PRTR (Pollutant Release and Transfer Register) Law.

For the fiscal year ended March 31, 2014, we set a company-wide target of reducing N,N-Dicyclohexylamine, a PRTR designated substance contained in metal cutting and grinding fluids, by 85% against the fiscal year ended March 31, 2011.

As of April 2013, as a result of efforts to replace the N,N-Dicyclohexylamine used at NTN MIE CORP. and NTN HAKUI CORP., NTN MIE CORP. completely eliminated this substance and the overall amount used was reduced by 82% against the fiscal year ended March 31, 2011. Our target for the fiscal year ending March 31, 2015 is total elimination at all sites.

Reducing Risk of Oil Leaks

In August 2013, NTN KINAN CORP. installed more oil separators, which separate oil and water, at its No. 1 Plant. It also took measures to lower the risk of oil leaks; for example, to be prepared for a possible oil leak, it installed an oil retaining wall on its rainwater drainage channel.

Hazardous Substance Audits

The NTN Group in Japan conducts hazardous substance audits internally for the specific purpose of determining the state of environmentally hazardous substances. These audits determine if substances are being properly managed on a continuing basis. If problems are found, measures are formulated to solve them.

The hazardous substance auditors who conduct these audits take ongoing training. After training at NTN HOUDATSU SHIMIZU CORP. and IWATA WORKS, there were 142 auditors as of March 2014.

NTN Group companies participate whenever possible in local environmental protection activities and strive to preserve a range of ecosystems.



Planting trees at NTN Komorebi no Mori in Kuwana City



Forest management activity in Nagano Prefecture



NTN employees help the "Clean Beach Ishikawa"



Planting trees at a factory in India

Protecting Biodiversity

Preserving the Natural Environment and Repairing Ecosystems

The NTN Group works to preserve nature and protect biodiversity around its bases.

Continuing Progress at 6 NTN Kigyo no Mori Sites in Japan

Since 2002, the NTN Group in Japan has been using mountainous areas near its sites for employees, their families, and local citizens to work to repair forests under the NTN Kigyo no Mori initiative.

Total Area of Forests Cared For by NTN

43.9 hectares

NTN Kigyo no Mori Activities (Fiscal Year Ended March 31, 2014)

Activity	Overview	Activity start	Size (hectares)
"Mori-no-satooya" program (Adopt-a-Forest)	Employees team up with the municipality for forest conservation activities such as planting trees and clearing underbrush. (Komagane City, Nagano Prefecture)	since April 2006	21.9
"Nagomi-no mori" (Forest of Relaxation)	Employees conduct forest conservation activities such as planting trees and clearing underbrush. (Nishimuro County, Wakayama Prefecture)	since June 2007	1.0
"Shizuoka mirai-no mori supporter" system (Supporters of Shizuoka's future forest)	Besides forest conservation activities such as clearing underbrush, employees build and maintain a hiking trail and manage a forest that is home to many birds. (Iwata City, Shizuoka Prefecture)	since April 2008	15.0
"Kigyo tono kyodo no mori zukuri" agreement (Public corporate forest-planting)	Besides planting trees and conducting forest conservation activities, employees hold nature walks. (Mimasaka City, Okayama Prefecture)	since August 2008	1.0
"NTN Komorebi no Mori"	At Tadoyama, employees plant trees and forest thinning, build and maintain a hiking trail, and hold nature walks. (Kuwana City, Mie Prefecture)	since November 2010	4.5
"NTN Okukawachi Lakeside Forest"	Employees plant trees and forest thinning, at Takihata Dam. (Kawachinagano City, Osaka Prefecture)	since November 2012	0.5

NTN Kigyo no Mori Events Held Around Japan

In March 2014, a total of 56 participants took part in a tree-planting event at the NTN Komorebi no Mori in Kuwana City, Mie Prefecture. Participants were from NTN bases in the region including KUWANA WORKS, the ADVANCED TECHNOLOGY R&D CENTER, NTN ENGINEERING PLASTICS CORP., and NTN TADO CORP., as well as the local government. This was the seventh tree-planting event and was led by Mori no Kaze, a non-profit organization (NPO). The children in attendance received instruction on forests and the importance of biodiversity.

At the NTN Kigyo no Mori in Komagane City, Nagano Prefecture in May 2014, 34 employees and their family members took part in a forest management activity. In this year's edition, the eighth since starting in 2006, the Kamiina Forestry Union and the Komagane Municipal Agricultural Division led forest management activities and a lesson in growing shiitake mushrooms.

This activity was part of Nagano Prefecture's Forest Promotion Project, under which approximately 50 hectares of forest was managed over eight years. In March 2014, NTN received a certificate from the Nagano Prefectural government stating that its Kigyo no Mori absorbs approximately 150 tons of CO₂ per year. Over the next three years we plan to manage a further 21.9 hectares.

Volunteering for Environmental Protection Activities

NTN employees regularly take part in local environmental events. In the fiscal year ended March 31, 2014, employees from NTN HOUDATSU SHIMIZU CORP. and NTN SHIKA CORP. joined in the "Clean Beach Ishikawa" event to pick up litter along Chirihama Beach.

Planting Trees on the Factory Grounds in India

Every year since 2012 on June 5, Earth Day, NTN NEI Manufacturing India Private LTD. holds a commemorative tree-planting event.

In the fiscal year ended March 31, 2014, 40 employees from all divisions took part to plant a total of 50 trees of different species such as blackberry, Indian rosewood, and Gulmohar. Participants helped raise their own environmental awareness by chanting the company's environmental policy.

NTN Report 2014 Third-Party Opinion

This is my third time presenting a third-party opinion on the social and environmental aspects of the NTN Report. I would like to start by evaluating the progress NTN has made on the suggestions I have made in the past.

First, with violations of the Anti-Monopoly Act continuing to have a major effect on the company's performance, being thoroughly in compliance is at the top of NTN's to-do list. With regards to this, last year in this column I pointed out the need for NTN to raise compliance awareness among everyone from top management to all levels of employees; to strengthen the system of compliance conduct and improve compliance-related training of human resources in each of NTN's worldwide business regions; and to improve information disclosure. And I praise NTN for taking a major step towards solving these by creating a worldwide system to spearhead compliance efforts. In April 2014, NTN established the CSR Headquarters, which integrated the CSR Department, the Legal Department, and the Fair Trade Promoting Department; and it set up an internal control section in each of the Offices of General Managers. In carrying out ongoing efforts that make use of this new system, it is crucial that top management continue to demonstrate unflinching resolve and leadership. The outside directors and outside auditors play an important role. Also crucial is the Internal Audit Department, which assesses self-audits in each department and supervises the progress of improvement measures. I think that the Internal Audit Department's role and systems should be strengthened and it should work closely with the CSR Headquarters. In proceeding with its global efforts, I would like to see NTN draw a roadmap showing exactly how much it hopes to accomplish by when, and disclose information on the progress with this roadmap.

Second, last year I also pointed out the need for NTN to stipulate key targets for efforts on the social side. In response, the newly established CSR Headquarters setting of action themes to strengthen risk assessment, disseminate and implement compliance, practice fair trade, and contribute to society is a positive step. NTN also set target values for the number of female managers. Beyond this, I would like to see the company formulate a clear medium-term plan for CSR that covers all efforts on the social side, including labor, human rights, supply chain management, and community service. I am also concerned that the NTN Report only includes social activities in Japan. It's imperative that a company like NTN doing business around the world report on its global social activities. Also limited in scope to suppliers and domestic bases in Japan is information on supply chain management. In human rights as well, I would like to see reports on how overseas companies perceive human rights issues and what they are doing about it. In the environmental area, NTN has been steadily moving ahead; for example, it is building a group-wide environmental management system, reducing environmentally hazardous substances, and conducting environmental protection activities.

Third, as I said last year, I look forward to seeing what NTN will do in the way of establishing a dialogue with stakeholders. Unfortunately, I haven't seen any progress on this front. This is because the key action themes that NTN set this past year are, as far as I can see, those that the company sees as the most immediately pressing. In areas I mentioned above, such as human rights and supply chain management, I hope to see NTN engage with non-profit organizations and other groups that represent the company's stakeholders. And in the area of social contribution, I believe NTN can make even greater advances and respond to the expectations of society by clarifying its basic policies.



Sachiko Kishimoto

Executive Director
Center for Public Resources
Development

Biographical Information

Worked for a private think-tank before founding the Public Resources Foundation in 2000. Has worked in her current position since 2013. Areas of specialty include promoting the culture of donating, not-for-profit management, CSR assessment, and ways that corporations that contribute to society. Co-Chairperson of the CSR Review Forum-Japan. Officer for The Japan Association of Charitable Organizations. Guest lecturer in the graduate school of Rikkyo University.

Financial Review

Net Sales

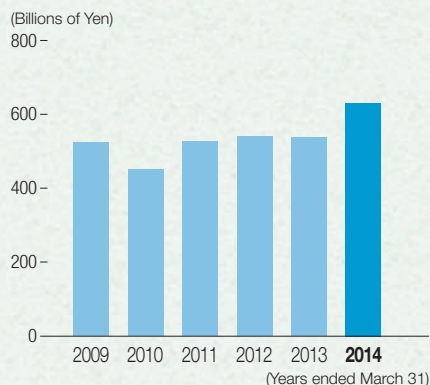

Net Sales by Business Segment / Business Sector

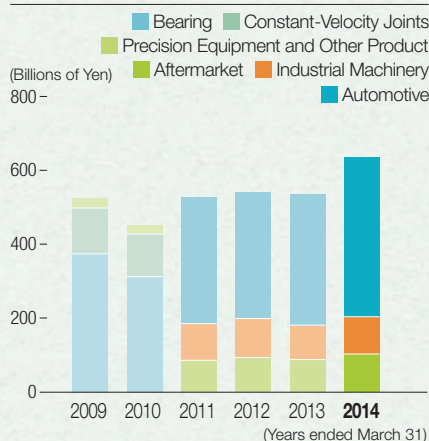

Note: Called "sales by business sector" starting in the fiscal year ended March 31, 2011

Net Sales by Region

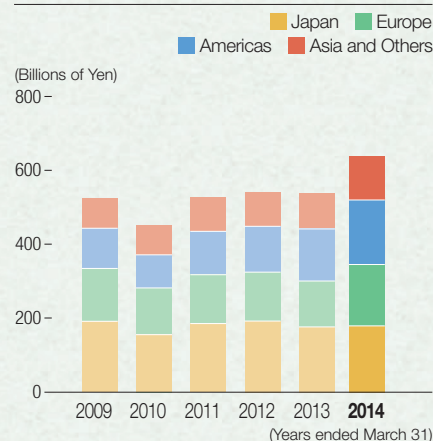

Scope of Consolidation

The scope of consolidation as of March 31, 2014 consisted of NTN Corporation and 65 consolidated subsidiaries (17 domestic and 48 overseas subsidiaries). A total of 9 affiliates (all overseas affiliates) were accounted for by the equity method. The following changes to the scope of consolidation and application of the equity method were made during the fiscal year under review.

◆ Consolidated Subsidiaries

(Four companies joining NTN Group)
 NTN MANUFACTURING DE MEXICO, S.A. DE C.V.
 Xiangyang NTN-Yulon Drivetrain Co., Ltd
 NTN Technical Service Corp.
 NTN LOGISTICS CO., LTD.
 (No decrease)

◆ Affiliates

(No change in number)

Summary of the Fiscal Year Ended March 31, 2014

In the fiscal year ended March 31, 2014, Japan's economy enjoyed moderate recovery thanks to factors including a correction of the high yen. Overseas, the U.S. economy continued its moderate recovery and Europe made a move in the same direction. Although China steadied off, other newly emerging countries saw slow economic growth.

Against this background, we have been implementing numerous measures with the aim of reforming business structure to generate profit under our Revival 2014 medium-term management plan, which we launched in April 2013.

- ◇ Net sales: 639.0 billion yen, a year-on-year increase of 99.4 billion yen (18.4%)
- ◇ Operating income: 33 billion yen (operating margin of 5.2%)
- ◇ Interest-bearing debt: 381.8 billion yen, an increase of 21 billion yen from March 31, 2013
- ◇ Capital expenditures: 33.2 billion yen, a year-on-year decrease of 15.8 billion (32.2%)
- ◇ Dividend: 2.0 yen (interim: 0 yen; year-end: 2.0 yen)

Net Sales and Earnings

Net sales and operating income both increased. Targets were achieved thanks to factors including increased customer demand and sales, and exchange-rate effects.

● Sales Performance

Consolidated net sales for the fiscal year ended March 31, 2014 were 638,971 million yen, an increase of 99,376 million yen (18.4%) year-on-year. Overseas sales totaled 459,889 million yen, an increase of 97,766 million yen (27.0%) year-on-year. Overseas sales accounted for 72.0% of net sales overall (Americas 27.3%, Europe 26.0%, Asia and others 18.6%), an increase of 4.9 percentage points from the previous fiscal year.

Net Sales and Earning by Business Sector

In the aftermarket, net sales were 103,845 million yen on increased customer demand in the automotive repair sector and exchange-rate effects. Operating income was 17,725 million yen.

The industrial machinery market had net sales of 101,181 million yen thanks to increased demand and exchange-rate effects. Operating income was 3,279 million yen due to a reduction of personnel costs and other fixed costs and exchange-rate effects.

In the automotive market, increased customer demand and exchange-rate effects resulted in net sales of 433,945 million yen. Operating income was 11,999 million yen due to factors including the effects of increased sales, decreased proportional costs, and the dissolution of temporal expenses incurred in the previous year because of an increased burden on production lines resulting from higher sales in the Americas.

Net Sales and Earning by Region

In Japan, aftermarket sales were down due to a drop in the aftermarket for industrial machinery. In industrial machinery as well, a drop in customer demand in China and other Asian countries resulted in lower sales in construction machinery and other sectors. In the automotive market, despite a drop following the end of the Japanese government's eco-car subsidy, sales were up overall thanks to factors including increased customer demand. The result was net sales of 179,082 million yen, up 0.9% over the previous fiscal year.

In Europe, sales were up in the aftermarket thanks to a recovery in customer demand in the automotive repair sector. Industrial machinery was little changed from the previous year, but in the automotive market, sales were up overall thanks to factors including increased customer demand. The result was net sales of 166,280 million yen (up 33.3%), helped partly by exchange-rate effects.

In the Americas, sales were up in the aftermarket thanks to a recovery in customer demand in the automotive repair sector. Industrial machinery saw a drop, particularly in sectors such as

Financial Review

Operating Income / Operating Margin

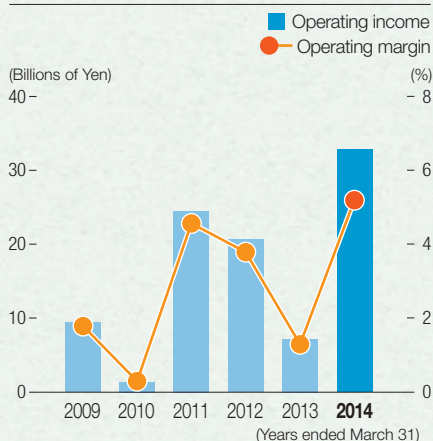

Net Income (Loss) / Ratio of Net Income (Loss) to Sales

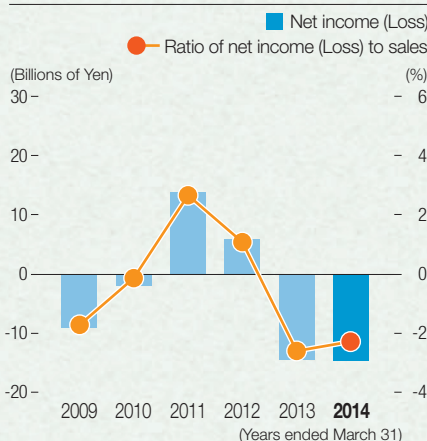

Capital Expenditures and Depreciation



construction machinery. In the automotive market, however, sales were up overall thanks to factors including increased customer demand. The result was net sales of 174,566 million yen (up 23.3%), helped partly by exchange-rate effects.

In Asia and other regions, aftermarket sales were down on decreases in industrial machinery repair products. In the industrial machinery market, sales were up in China on the strength of increased customer demand for wind turbine products but were down in other parts of Asia as customer demand decreased. In the automotive market, sales were down due to slower customer demand in Asian countries, although China saw a sales increase thanks to a recovery in business to Japanese manufacturers in that country and mass production of new orders. The result was net sales of 119,043 million yen (an increase of 24.3%), helped partly by exchange-rate effects.

● Cost of Sales and Selling, General and Administrative (SG&A) Expenses

The cost of sales was 525,935 million yen, down 3.3 percentage points and representing 82.3% of consolidated net sales. This was mainly due to decreased proportional costs.

Selling, general and administrative (SG&A) expenses were 80,032 million yen, representing 12.5% of consolidated net sales and 0.5 percentage points down.

● Earnings

Factors contributing to increased earnings included a decrease in fixed costs such as labor, favorable effects of exchange-rates, decreased proportional costs, and the dissolution of temporal expenses incurred in because of an increased burden on production lines resulting from higher sales in the Americas. As a result, the operating income for the term was 33,004 million yen, up 25,726 million yen over the previous fiscal year.

Other expenses amounted to a net expense of 35,455 million yen. Major contributing factors were income totaling 2,906 million yen, including a gain on securities contributed to employees' retirement benefit trust of 1,272 million yen, and expenses of 38,361 million yen, including losses related to the Anti-Monopoly Act of 27,024 million yen, impairment losses of 2,013 million yen, provision of reserve for losses on support of affiliates of 1,600 million yen, and business restructuring expense of 1,421 million yen.

As a result, the loss before income taxes was 2,451 million yen, an improvement from the 13,898 million yen loss of the previous fiscal year. The net loss per share was 27.54 yen for the year under review.

Although we have not yet decided on the dividend for the full fiscal year, we plan to resume the dividend (after foregoing it last year) in view of overall factors such as performance trends and the management environment, with an intended dividend of 2 yen per share.

■ R&D and Capital Expenditures

Increase in R&D Costs, Decrease in Capital Expenditures

● R&D Costs

R&D costs for the fiscal year under review were 17,821 million yen, up 1,647 million yen and representing 2.8% of consolidated net sales.

In the industrial machinery applications, NTN is positioning as key business sectors wind turbine, a form of new energy with promising global growth, and the sectors of rolling stock, aircraft, machine tools, and construction machinery, which all require state-of-the-art bearing technology. We are working to reduce environmental impact by developing more compact, lighter weight products with long life and low-torque, and by developing new products that meet customer needs for precision and speed, while at the same time focusing on basic technologies that will make us more competitive, and adding value by modularizing products such as sensors.

In the automotive market, besides boosting productivity in bearings and constant-velocity joints, we are beginning mass-production and market introduction of module products such as Ball Screw Drive Module for Electric Hydraulic Brake (which dramatically improve the efficiency of hybrid cars) and the Mechanical Clutch Unit (MCU) for Next-generation Steering, as well as preparing to expand the market for these products.

● Capital Expenditures

For NTN Corporation and its consolidated subsidiaries, the main focus of capital expenditures was on increasing production capacity, labor savings, and rationalization, maintaining and upgrading existing facilities, improving safety, and conducting R&D for new products.

In Japan, capital expenditures were 8,757 million yen, with projects including the expansion of plant buildings and constant-velocity joint production equipment at NTN FUKUROI CORP.

In the Americas, capital expenditures were 9,469 million yen, with projects including the expansion of plant buildings and the expansion of bearing production equipment at NTN-BOWER CORP., and the expansion of bearing production equipment at AMERICAN NTN BEARING MFG. CORP.

In Europe, capital expenditures were 7,121 million yen, with

Inventories / Inventory Turnover Ratio

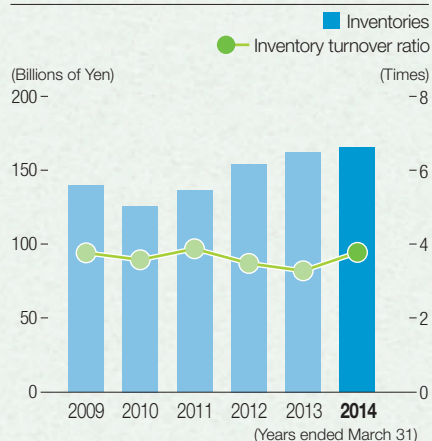

Interest-Bearing Debt

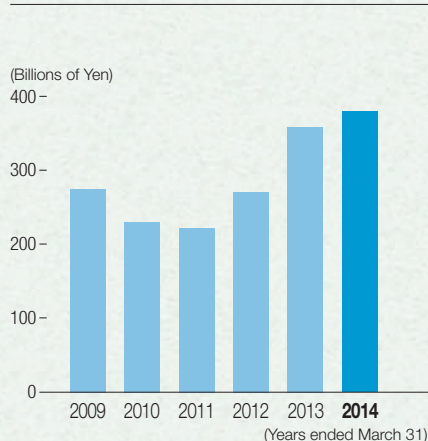

projects including the expansion of plant buildings at and the expansion of bearing production equipment at NTN-SNR ROULEMENTS, and the expansion of constant-velocity joint production equipment at NTN TRANSMISSIONS EUROPE.

In Asia and other areas, capital expenditures were 7,818 million yen. Projects included the expansion of bearing production equipment at Shanghai NTN Corp., the expansion of constant-velocity joint production equipment at Guangzhou NTN-Yulon Drivetrain Co., Ltd., and the expansion of bearing production equipment at NTN MANUFACTURING (THAILAND) CO.,LTD. After adjusting for 4 million yen in equipment transfers between segments, total capital expenditures for the fiscal year under review were 33,162 million yen.

All expenditures were funded from internal funds and short-term loans. Depreciation for the fiscal year under review amounted to 39,315 million yen (up 4,474 million yen from the previous fiscal year).

Financial Position and Cash Flows

Interest-Bearing Debt Increased by 21.0 Billion Yen. Free Cash Flow was 34.9 Billion yen

Total current assets at the fiscal year-end amounted to 467,748 million yen, an increase of 66,427 million yen, or 16.6%, from the end of the previous fiscal year. This was the result of an increase in cash and cash equivalents of 43,571 million yen, an increase in accounts receivable of 14,979 million yen, and an increase in inventory of 3,197 million yen. Property, plant, and equipment were 309,391 million yen, up 11,238 million yen (3.8%) over the previous fiscal year-end. This came mainly from an increase of 49,439 million in machinery, equipment and other vehicles. As a result, total assets were 848,037 million yen, up 79,575 million yen (10.4%) over the end of the previous fiscal year.

Current liabilities were 315,218 million yen, about the same as the previous year. Long-term liabilities were up 78,093 million yen (32.4%) over the end of the previous fiscal year to 319,450 million yen. This was mainly due to an increase in long-term loans and lease obligations of 61,456 million yen. As a result, total liabilities were 634,668 million yen, up 77,949 million yen (14.0%) over the end of the previous fiscal year.

Total net assets were 213,369 million yen, increased 1,626 million yen (0.8%) over the end of the previous fiscal year. This was mainly due to an increase in currency translation adjustments of 16,400 million yen and a decrease in retained earnings of 13,884 million yen.

The shareholders' equity ratio was 23.5%, down 2.5 percentage points. Total net assets per share, based on the number of shares

outstanding over the end of the previous fiscal year, were 374.68 yen per share (a decrease of 1.16 yen per share over the end of the previous fiscal year). Interest-bearing debt amounted to 381,767 million yen, an increase of 20,967 million yen (5.8%) from the end of the previous fiscal year. Factoring in the 14,427 million yen increase from currency effects, the actual increase was 6,540 million yen. The ratio of interest-bearing debt to total assets was 45.0% (down 2.0 percentage points).

Net working capital was 152,530 million yen, an increase of 66,570 million yen from the end of the previous fiscal year. The current ratio was 148.4% (up of 21.1 percentage point over the end of the previous fiscal year).

The inventory turnover ratio was 3.8 times (0.5 times up over the end of the previous fiscal year), while the turnover ratio of total assets was 0.8 times (up 0.1 times).

Net cash provided by operating activities was 69,058 million yen, an increase of 48,553 million yen, or 236.8%, over the end of the previous fiscal year. This mainly reflected inflows in the form of depreciation of 39,315 million yen, an increase of 27,024 million yen in accrued liability related to losses related to the Anti-Monopoly Act an increase in trade payables of 14,804 million yen, and a decrease in inventory of 9,105 million yen; offset against outlays of payments related to the Anti-Monopoly Act of 7,231 million yen and an increase in trade receivables of 7,197 million yen.

Net cash used in investing activities was 34,131 million yen (down 22,473 million yen, or 39.7%, over the previous fiscal year). This was due mainly to outlays of 33,351 million yen through the purchases of property, plant, and equipment.

Net cash provided by financing activities was 6,596 million yen, down 62,990 million yen (90.5%) over the previous fiscal year. This mainly reflected an inflow from long-term loans of 83,694 million yen, set against a payment of 65,710 million yen for long-term loans and a net decrease in short-term loans of 11,594 million yen.

Factoring in the 1,515 million yen increase due to the effect of exchange-rate changes, along with an increase of 533 million yen in cash and cash equivalents from newly consolidated subsidiaries, cash and cash equivalents at the end of the fiscal year were 129,671 million yen, up 43,571 million yen (50.6%) over the end of the previous fiscal year.

Free cash flow, the difference between net cash provided by operating activities and net cash used in investing activities, amounted to 34,927 million yen.

The proportion of net cash provided by operating activities to net sales was 10.8%.

Main Financial Indexes: 11-Year Summary

NTN Corporation and consolidated subsidiaries Years ended March 31

	2004	2005	2006	2007	2008
FOR THE YEAR DATA					
Net sales (Millions of yen)	357,394	388,349	434,837	483,818	533,985
Operating income (Millions of yen)	24,709	33,201	37,645	46,793	49,612
Operating margin (%)	6.9	8.5	8.7	9.7	9.3
Income (loss) before income taxes (Millions of yen)	18,181	26,586	30,370	45,170	44,313
Net income (loss) (Millions of yen)	11,032	16,740	19,550	27,014	27,431
Capital expenditures (Millions of yen)	38,092	49,670	49,284	59,347	59,504
Depreciation (Millions of yen)	23,979	24,870	28,586	32,693	39,547
R&D costs (Millions of yen)	13,543	14,952	14,771	14,221	15,006
YEAR-END DATA					
Total assets (Millions of yen)	460,341	516,578	561,494	611,944	629,464
Net assets/Shareholders' equity (Millions of yen)	142,487	157,952	183,247	215,815	216,401
Inventories (Millions of yen)	83,565	93,167	107,047	107,131	109,969
Interest-bearing debt (Millions of yen)	164,090	176,185	183,198	197,911	212,874
Number of employees	11,885	12,788	14,631	17,306	18,960
PER SHARE DATA					
Net assets (Yen)	308.27	341.93	396.73	445.61	445.98
Net income (loss):					
- Basic (Yen)	23.54	35.83	41.94	58.34	58.43
- Diluted (Yen)	21.87	32.94	38.55	53.74	54.59
Cash dividends (Yen)	5.50	8.50	11.00	16.00	19.00
OTHER INFORMATION					
Inventory Turnover Ratio (Times)	4.3	4.2	4.1	4.5	4.9
Net D/E ratio	0.86	0.79	0.80	0.79	0.86
Net income (loss)/Average total assets (ROA) ... (%)	2.4	3.4	3.6	4.6	4.4
Net income (loss)/ Average shareholders' equity (ROE) (%)	8.0	11.1	11.5	13.8	13.1
NTN-ROI	6.1	7.7	7.7	8.6	8.6
Shareholders' equity ratio (%)	31.0	30.6	32.6	34.2	33.3

Note 1: U.S. dollar amounts have been converted from yen, for convenience only, using the approximate exchange rate on March 31, 2014, which was U.S.\$1 = ¥102.92.

Thousands of U.S. dollars
(except per share amounts)

2009	2010	2011	2012	2013	2014	2014
527,100	452,746	530,056	543,468	539,595	638,971	\$6,208,424
9,479	1,399	24,560	20,724	7,278	33,004	320,676
1.8	0.3	4.6	3.8	1.3	5.2	5.2
(10,104)	(1,838)	22,855	16,357	(13,898)	(2,451)	(23,815)
(8,985)	(2,015)	14,399	5,993	(14,196)	(14,648)	(142,324)
49,594	21,504	29,700	54,440	48,979	33,162	322,211
45,759	40,702	35,936	34,175	34,841	39,315	381,996
17,402	14,687	15,697	17,157	16,174	17,821	173,154
627,613	618,802	632,001	693,258	768,462	848,037	8,239,769
192,223	214,551	210,353	212,126	211,743	213,369	2,073,154
140,466	126,663	136,985	155,107	163,287	166,484	1,617,606
275,996	231,638	223,284	271,978	360,802	381,767	3,709,357
20,679	17,959	19,172	20,789	21,398	22,156	22,156
376.77	374.19	376.05	370.19	375.84	374.68	3.64
(19.14)	(4.00)	27.08	11.27	(26.69)	(27.54)	0.27
–	–	–	–	–	–	–
13.00	8.00	10.00	10.00	0	2.00	0.02
3.8	3.6	3.9	3.5	3.3	3.8	
1.38	1.00	0.92	1.11	1.37	1.27	
(1.3)	(0.3)	2.3	0.9	(1.9)	(1.8)	
(4.3)	(1.1)	7.2	3.0	(7.2)	(7.3)	
1.5	0.2	4.2	3.4	1.1	4.6	
28.2	32.2	31.6	28.4	26.0	23.5	

Risk Factors

Business results and the financial position of the NTN Group are subject to the following risks. It should be noted that the forward-looking statements contained in the following reflect judgments of the NTN Group as of the submission date of our securities report (June 26, 2014).

1) Economy

The NTN Group operates global production and sales networks, and supplies customers in various industrial sectors. Business results and the financial position of the NTN Group operations may be affected by the economic conditions in specific countries and business conditions in industries to which our customers belong.

2) Foreign Exchange Fluctuations

Overseas sales of the NTN Group account for over 50% of consolidated sales. This percentage is expected to increase further due to continued acceleration in the global business development of the NTN Group.

Overseas subsidiaries' foreign currency-denominated business results and financial positions are converted to yen for the preparation of consolidated financial statements. Moreover, many export transactions with overseas customers of the Company are conducted in foreign currencies. Although the NTN Group hedges risks through forward foreign exchange contracts and expansion of local procurement, effects of exchange rate fluctuations on business results and financial positions cannot be fully eliminated.

3) Declines in Market Prices

The competitive environment surrounding production and sales activities of the NTN Group is becoming harsher worldwide. As products from China and Eastern Europe are gaining ground, bearings have been affected by falling market prices. At the same time, against a backdrop of global price competition, calls for price reductions are mounting in the automotive industry, which accounts for over half of the NTN Group sales. Although the NTN Group works continuously to reduce costs while developing new products of high quality and high added value, business results and the NTN Group's financial position may be affected by downward pressure on market prices.

4) Rise in Raw Materials Prices

The NTN Group procures a wide range of raw materials from outside sources. To deal with cost increases, especially of steel materials, which pose a high weighting in materials costs, measures have been taken such as mark-ups on selling prices to reflect higher materials cost. In addition, the Group is targeting cost reductions through enhanced production yields and VA/VE methods. Nevertheless, business results and the NTN Group's financial position may be affected by stronger than expected increases in raw materials costs.

5) Disasters and Accidents

Production plants and facilities of the NTN Group and its transaction counterparts are exposed to the risk of damage from natural disasters such as earthquakes, floods, and fires. Although the NTN Group has put into place crisis management systems and stands ready to engage in measures to contain damage as much as possible, risks cannot be completely eliminated. Business performance and the financial status of the NTN Group may be affected by a natural disaster or by accidents.

6) Dependence on Specific Industries

The NTN Group's Bearings Division derives approximately half of its sales revenues from the automotive industry, which also accounts for more than half of sales of components that the Constant-velocity Joints Division produces for automotive power transmission to the drive axle. Dependence on the automotive industry is therefore high. Although the NTN Group works to increase sales of bearings and precision equipment products to the industrial machinery sector and implements policies to achieve a balanced sales structure, a rapid shift in demand in the automotive industry could potentially affect the NTN Group's business results and financial position.

7) Product Defects

To ensure product quality, the NTN Group works to satisfy customers' requirements concerning product functions and specifications, and strives to provide appropriate quality and product safety by enforcing quality assurance globally. However, a substantial product defect leading to a serious accident, claim for damages, or product recall could entail huge product warranty costs and potentially affect business performance and the financial position of the NTN Group. Although the NTN Group has taken out global product liability insurance, complete coverage for loss is not possible.

8) Intellectual Property

The NTN Group generates a wealth of innovative technologies and know-how in the process of new product development, representing valuable intellectual property for which the NTN Group files patent applications to protect its rights. However, business performance and the financial position of the NTN Group may be affected if a legal challenge is initiated against its intellectual property or if its intellectual property is infringed by a third party.

9) Global Operations

The NTN Group develops its business operations worldwide with overseas sales exceeding 50% of consolidated sales. Overseas business development is associated with the following risks:

- a. Risks from unforeseen change in tax systems of or between individual countries
- b. Risks from unforeseen change in laws of individual countries
- c. Difficulty in hiring and retaining appropriate staff
- d. Evolving technology levels and unstable labor relations in emerging economies
- e. Political instability in emerging economies

10) Statutory Regulations

The NTN Group is subject to the various laws and regulations (tax laws, environmental laws, occupational safety and health laws, economic statutes such as antimonopoly laws and anti-dumping laws, trade and exchange laws, and securities trading regulations) of the countries and regions in which it does business.

The NTN Group strives to abide by these laws and regulations and conduct fair business activities. However, if the NTN Group is ever be subject to litigation or involved in legal proceedings because of a violation of a law or regulation, and if the decision of such litigation or legal proceedings goes against the Group, this may have an affect on the business performance or the financial state of the Group. As well, if these laws or regulations change, or if new unforeseen laws or regulations are enacted, these also may have an affect on the business performance or the financial state of the Group.

Consolidated Balance Sheets

March 31, 2014 and 2013

	Millions of yen		Thousands of U.S. dollars (Note 1)
	2014	2013	2014
Assets			
Current assets:			
Cash and cash equivalents (Note 14)	¥ 129,671	¥ 86,100	\$ 1,259,920
Short-term investments (Note 14)	2,076	692	20,171
Trade receivables (Note 14):			
Notes	12,357	10,590	120,064
Accounts	123,001	108,022	1,195,113
Allowance for doubtful accounts	(895)	(937)	(8,696)
	134,463	117,675	1,306,481
Inventories (Note 5)	166,484	163,287	1,617,606
Deferred income taxes (Note 23)	7,952	7,377	77,264
Other current assets (Note 14)	27,102	26,190	263,331
Total current assets	467,748	401,321	4,544,773
Property, plant and equipment, at cost (Note 6):			
Land (Note 2(g))	32,632	32,157	317,062
Buildings and structures (Note 2(g))	190,395	173,323	1,849,932
Machinery, equipment and vehicles (Note 2(g))	746,301	696,862	7,251,273
Construction in progress	19,914	27,961	193,490
	989,242	930,303	9,611,757
Less accumulated depreciation	(679,851)	(632,150)	(6,605,626)
Property, plant and equipment, net (Note 25)	309,391	298,153	3,006,131
Investments and other assets:			
Investment securities (Notes 7 and 14)	30,413	27,601	295,501
Investments in unconsolidated subsidiaries and affiliates (Note 14)	15,540	13,690	150,991
Goodwill	266	272	2,585
Deferred income taxes (Note 23)	16,978	20,904	164,963
Other assets	7,701	6,521	74,825
Total investments and other assets	70,898	68,988	688,865
Total assets (Note 25)	¥ 848,037	¥ 768,462	\$ 8,239,769

See accompanying notes to the consolidated financial statements.

Consolidated Balance Sheets

March 31, 2014 and 2013

	Millions of yen		Thousands of U.S. dollars (Note 1)
	2014	2013	2014
Liabilities and net assets			
Current liabilities:			
Short-term bank loans (Notes 8 and 14)	¥ 100,756	¥ 105,706	\$ 978,974
Current portion of long-term debt and lease obligations (Notes 8 and 14)	29,237	64,961	284,075
Trade payables (Note 14):			
Notes	14,693	11,677	142,761
Accounts	91,717	76,782	891,148
	106,410	88,459	1,033,909
Accrued income taxes (Notes 14 and 23)	3,424	1,485	33,269
Deferred income taxes (Note 23)	–	74	–
Provision for loss on support to a related company (Note 18)	1,602	–	15,565
Provision for surcharge payments under the Anti-Monopoly Act (Note 21)	35	7,231	340
Provision for employees' early retirement incentive plans (Note 20)	–	5,923	–
Other current liabilities	73,754	41,523	716,615
Total current liabilities (Note 25)	315,218	315,362	3,062,747
Long-term liabilities:			
Long-term debt and lease obligations (Notes 8 and 14)	253,192	191,736	2,460,086
Accrued retirement benefits for employees (Note 9)	–	37,880	–
Liability for retirement benefits (Note 9)	54,248	–	527,089
Provision for product defect compensation	932	1,164	9,056
Deferred income taxes (Note 23)	3,479	3,174	33,803
Other long-term liabilities	7,599	7,403	73,834
Total long-term liabilities (Note 25)	319,450	241,357	3,103,868
Contingent liabilities (Note 11)			
Net assets:			
Shareholders' equity (Note 10):			
Common stock:			
Authorized — 1,800,000,000 shares			
Issued — 532,463,527 shares in 2014 and 2013	54,347	54,347	528,051
Capital surplus	67,370	67,370	654,586
Retained earnings	82,856	96,740	805,052
Treasury stock, at cost:			
619,746 shares in 2014 and 576,643 shares in 2013	(534)	(517)	(5,188)
Total shareholders' equity	204,039	217,940	1,982,501
Accumulated other comprehensive income (loss):			
Net unrealized holding gain on securities (Note 7)	8,073	5,211	78,440
Translation adjustments	(1,728)	(18,128)	(16,790)
Retirement benefits liability adjustments	(11,111)	(5,119)	(107,958)
Total accumulated other comprehensive loss, net	(4,766)	(18,036)	(46,308)
Minority interests	14,096	11,839	136,961
Total net assets	213,369	211,743	2,073,154
Total liabilities and net assets	¥ 848,037	¥ 768,462	\$ 8,239,769

See accompanying notes to the consolidated financial statements.

Consolidated Statements of Operations

Years ended March 31, 2014 and 2013

	Millions of yen		Thousands of U.S. dollars (Note 1)
	2014	2013	2014
Net sales (Note 25)	¥ 638,971	¥ 539,595	\$ 6,208,424
Cost of sales (Note 16)	525,935	462,106	5,110,134
Gross profit	113,036	77,489	1,098,290
Selling, general and administrative expenses (Note 16)	80,032	70,211	777,614
Operating income (Note 25)	33,004	7,278	320,676
Other income (expenses):			
Interest and dividend income	928	820	9,017
Interest expense	(4,822)	(4,069)	(46,852)
Equity in earnings of affiliates	706	553	6,860
Gain on contribution of securities to employee's retirement benefit trust (Note 7)	1,272	-	12,359
Gain on bargain purchase of a subsidiary's shares (Note 25)	-	1,929	-
Gain on sales of investment securities (Note 7)	-	1,593	-
Loss on surcharge payments under the Anti-Monopoly Act (Note 17)	(27,024)	-	(262,573)
Loss on impairment of fixed assets (Note 6)	(2,013)	(2,693)	(19,559)
Provision for loss on support to a related company (Note 18)	(1,600)	-	(15,546)
Reorganization expenses (Note 19)	(1,421)	(3,027)	(13,807)
Restructuring costs (Note 20)	(301)	(6,365)	(2,925)
Provision for surcharge payments under the Anti-Monopoly Act (Note 21)	(35)	(7,231)	(340)
Loss on valuation of investment securities	-	(491)	-
Casualty losses	-	(126)	-
Other, net	(1,145)	(2,069)	(11,125)
	(35,455)	(21,176)	(344,491)
Loss before income taxes and minority interests	(2,451)	(13,898)	(23,815)
Income taxes (Note 23):			
Current	6,744	2,936	65,527
Deferred	4,887	(3,116)	47,483
	11,631	(180)	113,010
Loss before minority interests	(14,082)	(13,718)	(136,825)
Minority interests	(566)	(478)	(5,499)
Net loss	¥ (14,648)	¥ (14,196)	\$ (142,324)

See accompanying notes to the consolidated financial statements.

Consolidated Statements of Comprehensive Income

Years ended March 31, 2014 and 2013

	Millions of yen		Thousands of U.S. dollars (Note 1)
	2014	2013	2014
Loss before minority interests	¥ (14,082)	¥ (13,718)	\$ (136,825)
Other comprehensive income (loss) (Note 22):			
Net unrealized holding gain on securities (Note 7)	2,863	1,815	27,818
Translation adjustments	15,378	19,502	149,417
Retirement benefit liability adjustments	1,821	(1,092)	17,694
Share of other comprehensive income of affiliates accounted for by the equity method	1,980	1,581	19,238
Other comprehensive income, net	22,042	21,806	214,167
Comprehensive income	¥ 7,960	¥ 8,088	\$ 77,342
Total comprehensive income attributable to:			
Shareholders of NTN Corporation	¥ 6,226	¥ 5,662	\$ 60,494
Minority interests	¥ 1,734	¥ 2,426	\$ 16,848

See accompanying notes to the consolidated financial statements.

Consolidated Statements of Changes in Net Assets

Years ended March 31, 2014 and 2013

Millions of yen										
	Number of shares in issue	Common stock	Capital surplus	Retained earnings	Treasury stock, at cost	Net unrealized holding gain on securities	Translation adjustments	Retirement benefit liability adjustments	Minority interests	Total net assets
Balance at April 1, 2012	532,463,527	¥ 54,347	¥ 67,370	¥ 113,595	¥ (514)	¥ 3,396	¥ (37,263)	¥ (4,027)	¥ 15,222	¥ 212,126
Cash dividends paid	—	—	—	(2,659)	—	—	—	—	—	(2,659)
Net loss	—	—	—	(14,196)	—	—	—	—	—	(14,196)
Purchases of treasury stock	—	—	—	—	(4)	—	—	—	—	(4)
Sales of treasury stock	—	—	—	—	1	—	—	—	—	1
Other changes	—	—	—	—	—	1,815	19,135	(1,092)	(3,383)	16,475
Balance at April 1, 2013	532,463,527	¥ 54,347	¥ 67,370	¥ 96,740	¥ (517)	¥ 5,211	¥ (18,128)	¥ (5,119)	¥ 11,839	¥ 211,743
Net loss	—	—	—	(14,648)	—	—	—	—	—	(14,648)
Net effect of change in scope of consolidation	—	—	—	764	—	—	—	—	—	764
Purchases of treasury stock	—	—	—	—	(18)	—	—	—	—	(18)
Sales of treasury stock	—	—	—	—	1	—	—	—	—	1
Other changes	—	—	—	—	—	2,862	16,400	(5,992)	2,257	15,527
Balance at March 31, 2014	532,463,527	¥ 54,347	¥ 67,370	¥ 82,856	¥ (534)	¥ 8,073	¥ (1,728)	¥ (11,111)	¥ 14,096	¥ 213,369

Thousands of U.S. dollars (Note 1)										
	Common stock	Capital surplus	Retained earnings	Treasury stock, at cost	Net unrealized holding gain on securities	Translation adjustments	Retirement benefit liability adjustments	Minority interests	Total net assets	
Balance at April 1, 2013	\$ 528,051	\$ 654,586	\$ 939,953	\$ (5,023)	\$ 50,632	\$ (176,137)	\$ (49,738)	\$ 115,031	\$ 2,057,355	
Net loss	—	—	(142,324)	—	—	—	—	—	(142,324)	
Net effect of change in scope of consolidation	—	—	7,423	—	—	—	—	—	7,423	
Purchases of treasury stock	—	—	—	(175)	—	—	—	—	(175)	
Sales of treasury stock	—	—	—	10	—	—	—	—	10	
Other changes	—	—	—	—	27,808	159,347	(58,220)	21,930	150,865	
Balance at March 31, 2014	\$ 528,051	\$ 654,586	\$ 805,052	\$ (5,188)	\$ 78,440	\$ (16,790)	\$ (107,958)	\$ 136,961	\$ 2,073,154	

See accompanying notes to the consolidated financial statements.

Consolidated Statements of Cash Flows

Years ended March 31, 2014 and 2013

	Millions of yen		Thousands of U.S. dollars (Note 1)
	2014	2013	2014
Cash flows from operating activities:			
Loss before income taxes and minority interests	¥ (2,451)	¥ (13,898)	\$ (23,815)
Adjustments for:			
Depreciation and amortization	39,315	34,841	381,996
Loss on impairment of fixed assets (Note 6)	2,197	2,838	21,347
Amortization of goodwill	134	128	1,302
Gain on bargain purchase of a subsidiary's share	–	(1,929)	–
(Decrease) increase in provision for surcharge payments under the Anti-Monopoly Act	(7,196)	7,231	(69,918)
(Decrease) increase in provision for employees' early retirement incentive plans	(5,860)	5,911	(56,937)
Increase in provision for loss on support to a related company	1,559	–	15,148
(Decrease) increase in allowance for doubtful accounts	(122)	126	(1,185)
Increase (decrease) in allowance for directors' and corporate auditors' bonuses	12	(75)	117
Increase in accrued retirement benefits for employees	–	2,278	–
(Decrease) increase in provision for product defect compensation	(255)	352	(2,478)
Increase in liability for retirement benefits	9,100	–	88,418
Increase in account payable for Anti-Monopoly Act	27,024	–	262,573
Increase in other current liabilities for reorganization expenses	1,138	2,600	11,057
Decrease in other current and long-term liabilities resulting from amendment of pension plans	(999)	(1,205)	(9,707)
Severance payments under early retirement incentive plans	10,698	–	103,945
Surcharge payment under Anti-Monopoly Act	7,231	–	70,258
Interest and dividend income	(928)	(820)	(9,017)
Interest expense	4,822	4,069	46,852
Translation adjustments and foreign exchange (gain) loss, net	(1,420)	632	(13,797)
Equity in earnings of affiliates	(706)	(553)	(6,860)
Loss on sales of fixed assets, net	–	25	–
Gain on sales of investment securities, net	–	(1,589)	–
Loss on valuation of investment securities	–	491	–
Gain on contribution of securities to employee's retirement benefit trust	(1,272)	–	(12,359)
Contribution of securities to retirement benefit trust	1,864	–	18,111
(Increase) decrease in trade receivables	(7,197)	11,953	(69,928)
Decrease in inventories	9,105	4,457	88,467
Increase (decrease) in trade payables	14,804	(27,967)	143,840
Other	(4,039)	(3,947)	(39,245)
Subtotal	96,558	25,949	938,185
Interest and dividend income received	1,576	1,453	15,312
Interest paid	(4,912)	(3,973)	(47,726)
Severance payments under early retirement incentive plans	(10,698)	–	(103,945)
Payment for loss of Anti-Monopoly Act	(7,231)	–	(70,258)
Income taxes paid	(6,235)	(2,924)	(60,581)
Net cash provided by operating activities	¥ 69,058	¥ 20,505	\$ 670,987
Cash flows from investing activities:			
(Increase) decrease in short-term investments	(323)	1,150	(3,138)
Purchases of property, plant and equipment	(33,351)	(55,244)	(324,048)
Purchases of other assets	(1,843)	(1,536)	(17,907)
Proceeds from sales of property, plant and equipment	–	935	–
Purchases of investment securities	–	(893)	–
Proceeds from upfront portion for sales of property, plant and equipment	1,251	–	12,155
Proceeds from sales of investment securities	–	1,702	–
Purchases of investments in subsidiaries	(37)	(3,927)	(360)
Decrease in short-term loans receivable	–	1,026	–
Other	172	183	1,671
Net cash used in investing activities	(34,131)	(56,604)	(331,627)
Cash flows from financing activities:			
Decrease in short-term bank loans, net	(11,594)	(3,013)	(112,651)
Proceeds from long-term debt	83,694	89,248	813,195
Repayment of long-term debt, including current portion	(65,710)	(13,471)	(638,457)
Proceeds from issuance of common stock to minority shareholders of consolidated subsidiaries	801	230	7,783
Cash dividends paid	–	(2,659)	–
Repayment of lease obligations	(277)	(249)	(2,691)
Other	(318)	(500)	(3,090)
Net cash provided by financing activities	6,596	69,586	64,089
Effect of exchange rate changes on cash and cash equivalents	1,515	(208)	14,720
Net increase in cash and cash equivalents	43,038	33,279	418,169
Cash and cash equivalents at beginning of the year	86,100	52,606	836,572
Increase in cash and cash equivalents resulting from inclusion of subsidiaries in consolidation	533	215	5,179
Cash and cash equivalents at end of the year	¥ 129,671	¥ 86,100	\$ 1,259,920

See accompanying notes to the consolidated financial statements.

Notes to Consolidated Financial Statements

March 31, 2014

1. Basis of Preparation

The accompanying consolidated financial statements of NTN Corporation (the "Company") and consolidated subsidiaries are prepared on the basis of accounting principles generally accepted in Japan, which are different in certain respects as to the application and disclosure requirements of International Financial Reporting Standards, and are compiled from the consolidated financial statements prepared by the Company as required by the Financial Instruments and Exchange Act of Japan.

In preparing the accompanying consolidated financial statements, certain reclassifications have been made to the consolidated financial statements issued domestically in order to present them in a format which is more familiar to readers outside Japan. In addition, certain notes included herein are not required under accounting principles generally accepted in Japan but are presented as additional information.

The translation of yen amounts into U.S. dollar amounts is included solely for the convenience of readers outside Japan and has been made at ¥102.92 = U.S.\$1.00, the exchange rate prevailing on March 31, 2014. This translation should not be construed as a representation that yen can be converted into U.S. dollars at the above or any other rate.

2. Summary of Significant Accounting Policies

(a) Principles of consolidation

The accompanying consolidated financial statements include the accounts of the Company and the significant companies which it controls directly or indirectly. Companies over which the Company exercises significant influence in terms of their operating and financial policies have been included in the accompanying consolidated financial statements on an equity basis.

The financial statements of certain consolidated subsidiaries whose fiscal year end is December 31 have been included in consolidation on the basis of a full fiscal year closing on March 31 for consolidation purposes.

(b) Foreign currency translation

Monetary assets and liabilities denominated in foreign currencies are translated into yen at the rates of exchange in effect at the balance sheet date. Revenues and expenses are translated at the rates of exchange prevailing when the transactions were made.

Assets and liabilities of overseas consolidated subsidiaries are translated into yen at the exchange rates in effect at the respective balance sheet dates, except for the components of net assets excluding minority interests which are translated at the respective historical rates.

Revenue and expenses are translated at the average rates of exchange for the respective years. Differences arising from translation are reflected in "Translation adjustments" and "Minority interests" in the accompanying consolidated balance sheets and statements of changes in net assets.

(c) Cash and cash equivalents

Cash and cash equivalents consist of cash on hand, deposits with banks withdrawable on demand, and short-term investments which are readily convertible to cash subject to an insignificant risk of any change in their value and which were purchased with an original maturity of three months or less.

(d) Allowance for doubtful accounts

The allowance for doubtful accounts is computed based on the actual historical percentage of bad debts and an estimate of uncollectible amounts determined after an analysis of specific individual receivables.

(e) Short-term investments and investment securities

The accounting standard for financial instruments requires that securities be classified into three categories: trading, held-to-maturity or other securities. Trading securities are carried at fair value and held-to-maturity debt securities are carried at amortized cost. Marketable securities classified as other securities are carried at fair value with any changes in unrealized holding gain or loss, net of the applicable income taxes, included directly in net assets. Cost of securities sold is determined by the moving average method. Non-marketable securities classified as other securities are carried at cost based on the moving average method.

(f) Inventories

Inventories are principally stated at lower of cost, determined by the average method, or net selling value.

(g) Property, plant and equipment

Property, plant and equipment are stated at cost. Depreciation is computed at rates based on the estimated useful lives of the respective

assets by the declining-balance method, except for the buildings and assets of foreign consolidated subsidiaries to which the straight-line method is principally applied.

The principal estimated useful lives are as follows:

Buildings and structures	10 to 50 years
Machinery, equipment and vehicles	5 to 12 years

Contributions granted by national and municipal governments are deducted directly from the acquisition costs of the related fixed assets as stipulated in the Corporation Tax Law of Japan. The property, plant and equipment accounts on the consolidated balance sheets at March 31, 2014 and 2013 were reduced by the following amounts:

	Millions of yen		Thousands of U.S. dollars
	2014	2013	2014
Land	¥ 799	¥ 799	\$ 7,763
Buildings and structures	529	468	5,140
Machinery, equipment and vehicles	420	504	4,081

(h) Provision for loss on support to a related company

Provision for loss on support to a related company is provided for the possible loss on support provided to a related company due to the subsidiary's financial condition and other factors.

(i) Provision for surcharge payments under the Anti-Monopoly Act

Provision for surcharge payments under the Anti-Monopoly Act is provided for the expected corresponding payments.

(j) Liability for retirement benefits

Liability for retirement benefits has been provided principally at an amount calculated based on the retirement benefit obligation after the fair value of the pension plan assets are deducted. The estimated benefit is attributed to each period by the straight-line method over the estimated years of service of the eligible employees.

Past service cost is amortized in the year in which the gain or loss is recognized primarily by the straight-line method over a period of principally 15 years, which is within the estimated average remaining years of service of the eligible employees.

Net unrecognized actuarial gain or loss is amortized commencing in the year following the year in which the gain or loss was recognized primarily by the straight-line method over a period of principally 15 years, which is within the estimated average remaining years of service of the eligible employees.

(k) Provision for product defect compensation

Provision for product defect compensation is provided at an estimated amount in order to cover the anticipated compensation.

(l) Leases

For lease transactions involving the transfer of ownership, the leased assets are depreciated by the same methods used for owned fixed assets.

For lease transactions not involving the transfer of ownership, leased assets are depreciated over the lease period using the straight-line method with a nil residual value.

The Company and its domestic consolidated subsidiaries continue to account for finance lease transactions not involving the transfer of ownership that commenced prior to April 1, 2008 as operating leases.

(m) Goodwill

Goodwill is being amortized on the straight-line method over the estimated period of the economic benefits, with the exception of immaterial amounts, which are charged to income as incurred.

(n) Research and development costs and computer software

Research and development costs are charged to income as incurred.

Expenditures relating to computer software developed for internal use are charged to income when incurred, except if the software is expected to contribute to the generation of income or to future cost savings. Such expenditures are capitalized as assets and are amortized by the straight-line method over their respective estimated useful lives, generally a 5-year period.

(o) Deferred income taxes

Deferred income taxes are provided for temporary differences between the balances of assets and liabilities reported for financial reporting purposes and the corresponding balances for tax reporting purposes.

(p) Derivative financial instruments and hedging activities

All derivatives are stated at fair value with any changes in fair value included in profit or loss in the corresponding period, except for derivatives meeting the criteria for deferral hedge accounting under which realized gain or loss, net of the applicable income taxes, is deferred as a component of net assets. Receivables and payables hedged by forward foreign exchange contracts meeting certain conditions are translated at the corresponding foreign exchange contract rates (the "allocation method"). Interest-rate swap transactions meeting certain conditions for special treatment is accounted for as if the interest rates applied to the interest-rate swap had originally applied to the underlying debt (the "special treatment"). Cross currency swap meeting the conditions of both the allocation method and the special treatment are accounted for by translating the applicable interest rates the underlying foreign currency debt at the corresponding contract rates.

(q) Distribution of retained earnings

Under the Corporation Law of Japan and the Company's Articles of Incorporation, the distribution of retained earnings with respect to a given financial period is made by resolution of the shareholders at a general meeting held subsequent to the close of the financial period. The distribution of retained earnings with respect to the interim financial period is made by resolution of the Board of Directors. The accounts for the period do not reflect such distributions.

(r) Consolidated taxation system

The Company and certain domestic consolidated subsidiaries adopted the consolidated taxation system, which allows companies to file tax returns based on the combined profits or losses of the parent company and its wholly owned domestic subsidiaries.

3. Accounting Change

Accounting Standards for Retirement Benefits

Effective March 31, 2014, the Company and its domestic consolidated subsidiaries adopted "Accounting Standard for Retirement Benefits" (Accounting Standards Board of Japan ("ASBJ") Statement No.26 issued on May 17, 2012) and "Guidance on Accounting Standard for Retirement Benefits" (ASBJ Guidance No.25 issued on May 17, 2012), except provisions set forth in paragraph 35 of ASBJ Statement No.26 and paragraph 67 of ASBJ Guidance No.25.

In accordance with the adoption, the retirement benefit obligations after the fair value of the pension plan assets are deducted, and actuarial gains and losses and past service costs that have yet to be recognized in profit or loss are recorded as "Liability for retirement benefits".

The adoption of these standards follows transitional provisions set forth in paragraph 37 of the ASBJ Statement No.26. The effect of this change is included in accumulated other comprehensive income as "Retirement benefit liability adjustments".

As a result of this change "Liability for retirement benefits" was recorded in the amount of ¥54,248 million (\$527,089 thousand), other comprehensive income decreased by ¥7,604 million (\$73,883 thousand) and net assets per share decreased by ¥14.30 (\$0.14) as of March 31, 2014 from the corresponding amounts that would have been recorded under the previous method.

4. Standards Issued but Not Yet Effective

Accounting Standards for Retirement Benefits

On May 17, 2012, the Accounting Standards Board of Japan ("ASBJ") issued ASBJ Statement No.26, "Accounting Standard for Retirement Benefits" and ASBJ Guidance No.25, "Guidance on Accounting Standard for Retirement Benefits," which replaced the "Accounting Standard for Retirement Benefits" issued by the Business Accounting Council in 1998 with an effective date of April 1, 2000 and the other related practical guidance, being followed by partial amendments from time to time through 2009.

In accordance with the revision of this accounting standard, actuarial gains and losses and past service costs that have yet to be recognized in profit or loss shall be recognized within net assets after adjusting for tax effects, and the deficit or surplus shall be recognized as a liability or asset. Actuarial gains and losses and past service cost that arose in the current period and have yet to be recognized in profit or loss shall

be included in other comprehensive income and actuarial gains and losses and past service cost that were recognized in other comprehensive income in prior periods and then recognized in profit or loss in the current period shall be treated as reclassification adjustments. In addition, the new accounting standard allows a choice for the method of attributing expected benefits to periods between either the straight-line basis or the plan's benefit formula basis. In addition, the method used to determine the discount rate was revised.

The Company has adopted the revised accounting standard effective March 31, 2014 as mentioned in "3. Accounting Change." However, the amendment of the calculation method for the present value of defined obligations and current service costs will be adopted effective the beginning of the year ending March 31, 2015.

The effect of the change in the calculation method is estimated to decrease liability for retirement benefits and deferred income taxes by ¥3,557 million (\$34,561 thousand), ¥1,245 million (\$12,097 thousand), respectively, and to increase retained earnings at April 1, 2014 by ¥2,312 million (\$22,464 thousand). The effect of the change on the consolidated statement of operations for the year ending March 31, 2015 is expected to be immaterial.

5. Inventories

Inventories at March 31, 2014 and 2013 consisted of the following:

	Millions of yen		Thousands of U.S. dollars
	2014	2013	2014
Finished goods	¥ 90,541	¥ 92,771	\$ 879,722
Work in process	45,097	41,996	438,175
Raw materials and supplies	30,846	28,520	299,709
	¥ 166,484	¥ 163,287	\$ 1,617,606

Notes to Consolidated Financial Statements

March 31, 2014

6. Impairment of Fixed Assets

The Company and its consolidated subsidiaries group fixed assets used for manufacturing by management segment into minimum units which generate identifiable cash flows (e.g., a factory). They also group fixed assets used at the head office or used for sales activities as shared assets.

The Company and its consolidated subsidiaries wrote down the following assets to their respective net recoverable values because the Company and its consolidated subsidiaries do not expect any future use for them and do not expect them to be recoverable. Consequently, the Company and its consolidated subsidiaries recorded related losses on impairment of fixed assets of ¥2,013 million (\$19,559 thousand) and ¥2,693 million in the accompanying consolidated statements of operations for the years ended March 31, 2014 and 2013 respectively:

Location	Usage	Classification	Millions of yen		Thousands of U.S. dollars
			2014	2013	2014
Japan	Production equipment	Buildings and structures	¥ –	¥ 192	\$ –
		Machinery and equipment	167	269	1,623
		Construction in progress	453	334	4,401
		Other	–	20	–
	Employee recreational facilities	Buildings and structures	52	202	505
		Land	15	122	146
Other		0	1	0	
Americas	Production equipment	Machinery and equipment	1,040	8	10,105
		Construction in progress	185	183	1,798
		Other	101	–	981
	Production equipment and other	Machinery and equipment	–	235	–
Europe	Production equipment and other	Construction in progress	–	220	–
		Other	–	215	–
		Machinery and equipment	–	648	–
Asia and other areas	Production equipment	Construction in progress	–	39	–
		Other	–	5	–
			¥ 2,013	¥ 2,693	\$ 19,559

The recoverable value of the fixed assets presented in the above table has been measured primarily at net realizable value based on appraisals conducted by real estate appraisers or value in use. If a fixed asset cannot be sold or diverted to other usage, such asset is valued at nil.

The Company recorded reorganization expenses of ¥1,421 million (\$13,807 thousand), which included loss on impairment of fixed assets in the amount of ¥184 million (\$1,788 thousand) for the year ended March 31, 2014. The aggregate amount of ¥2,197 million (\$21,347 thousand) of loss on impairment of fixed assets included ¥2,013 million (\$19,559 thousand) as shown in the above table and the ¥184 million (\$1,788 thousand), which was included in the reorganization expenses mentioned above, was presented as a component of cash flows from operating activities in the consolidated statement of cash flows for the year ended March 31, 2014.

The Company recorded reorganization expenses of ¥3,027 million, which included loss on impairment of fixed assets in the amount of ¥145 million for the year ended March 31, 2013. The aggregate amount of ¥2,838 million of loss on impairment of fixed assets included ¥2,693 million as shown in the above table and the ¥145 million, which was included in the reorganization expenses mentioned above, was presented as a component of cash flows from operating activities in the consolidated statement of cash flows for the year ended March 31, 2013.

7. Securities

(a) Information regarding marketable securities classified as other securities at March 31, 2014 and 2013 is summarized as follows:

	Millions of yen					
	2014			2013		
	Carrying value	Acquisition costs	Unrealized gain (loss)	Carrying value	Acquisition costs	Unrealized gain (loss)
Securities whose carrying value exceeds their acquisition costs:						
Equity securities	¥ 26,129	¥ 13,673	¥ 12,456	¥ 19,880	¥ 11,213	¥ 8,667
Securities whose carrying value does not exceed their acquisition costs:						
Equity securities	2,779	3,124	(345)	5,398	6,176	(778)
Other	35,000	35,000	–	34,000	34,000	–
Subtotal	37,779	38,124	(345)	39,398	40,176	(778)
Total	¥ 63,908	¥ 51,797	¥ 12,111	¥ 59,278	¥ 51,389	¥ 7,889

	Thousands of U.S. dollars		
	2014		
	Carrying value	Acquisition costs	Unrealized gain (loss)
Securities whose carrying value exceeds their acquisition costs:			
Equity securities	\$ 253,877	\$ 132,851	\$ 121,026
Securities whose carrying value does not exceed their acquisition costs:			
Equity securities	27,001	30,353	(3,352)
Other	340,070	340,070	–
Subtotal	367,071	370,423	(3,352)
Total	\$ 620,948	\$ 503,274	\$ 117,674

Impairment losses are recorded for securities whose fair value has declined by 50% or more, or whose fair value has declined by 30% or more, but less than 50%, if the decline is deemed to be irrecoverable.

The Company has recognized impairment loss on valuation of investment securities of ¥490 million for the year ended March 31, 2013.

(b) Sales and aggregate gain on investment securities are summarized as follows:

	Millions of yen
	2013
Sales	¥ 1,692
Aggregate gain	1,593

The Company contributed certain available-for-sale securities with a fair value of ¥1,864 million (\$1,811 thousand) to the employee retirement benefit trust for the Company's contributory pension plan, and recognized gain of ¥1,272 million (\$12,359 thousand) for the year ended March 31, 2014.

8. Short-Term Bank Loans, Long-Term Debt and Lease Obligations

Short-term bank loans principally represent short-term notes with average annual interest rates of 0.78% and 0.76% at March 31, 2014 and 2013, respectively.

Long-term debt and lease obligations at March 31, 2014 and 2013 consisted of the following:

	Millions of yen		Thousands of U.S. dollars
	2014	2013	2014
Loans from banks and other financial institutions, due through 2023, at an average annual interest rate of 1.3%	¥ 281,011	¥ 245,096	\$ 2,730,383
1.66% unsecured bonds due 2013	-	10,000	-
Lease obligations due through 2027	1,418	1,601	13,778
	282,429	256,697	2,744,161
Less current portion	(29,237)	(64,961)	(284,075)
	¥ 253,192	¥ 191,736	\$ 2,460,086

The aggregate annual maturities of long-term debt and lease obligations subsequent to March 31, 2014 are summarized as follows:

Year ending March 31,	Millions of yen	Thousands of U.S. dollars
2015	¥ 29,237	\$ 284,075
2016	40,890	397,299
2017	69,410	674,407
2018	72,046	700,020
2019	39,609	384,852
2020 and thereafter	31,237	303,508
	¥ 282,429	\$ 2,744,161

9. Retirement Benefits

1. Outline of retirement benefits for employees

The Company and certain domestic consolidated subsidiaries have defined benefit pension plans (i.e., corporate pension fund plans and lump-sum payment plans), covering substantially all employees who are entitled to lump-sum or annuity payments, the amounts of which are determined by reference to their basic rates of pay, length of service, and the conditions under which termination occurs. They also have defined contribution pension plans and advance payment plans. Certain overseas consolidated subsidiaries also have defined benefit pension plans and/or defined contribution pension plans.

2. Defined benefit pension plans for the year ended March 31, 2014

(1) The change in retirement benefit obligation is outlined as follows:

	Millions of yen	Thousands of U.S. dollars
	2014	2014
Retirement benefit obligation at April 1, 2013	¥ 110,526	\$ 1,073,902
Service cost	3,311	32,171
Interest cost	2,282	22,173
Actuarial loss	(658)	(6,393)
Benefits paid	(13,204)	(128,294)
Other	3,996	38,825
Retirement benefit obligation at March 31, 2014	¥ 106,253	\$ 1,032,384

*Certain domestic consolidated subsidiaries calculate the liability for retirement benefits based on the simplified method.

Notes to Consolidated Financial Statements

March 31, 2014

(2) The change in plan assets at fair value is outlined as follows:

	Millions of yen	Thousands of U.S. dollars
	2014	2014
Plan assets at fair value at April 1, 2013	¥ 56,541	\$ 549,368
Expected return on plan assets	1,769	17,188
Actuarial gain	3,096	30,082
Contributions by the employer	4,111	39,944
Benefits paid	(16,221)	(157,608)
Other	2,709	26,321
Plan assets at fair value at March 31, 2014	¥ 52,005	\$ 505,295

(3) The balance of retirement benefit obligation and plan assets at fair value, liabilities and assets recognized in consolidated balance sheet are outlined as follows:

	Millions of yen	Thousands of U.S. dollars
	2014	2014
Funded retirement benefit obligation	¥ 98,539	\$ 957,433
Plan assets at fair value	(52,005)	(505,295)
	46,534	452,138
Unfunded retirement benefit obligation	7,714	74,951
Net amount of liabilities and assets recognized in the consolidated balance sheet	54,248	527,089
Liability for retirement benefits	54,248	527,089
Net amount of liabilities and assets recognized in the consolidated balance sheet	¥ 54,248	\$ 527,089

(4) The components of retirement benefit expenses are outlined as follows:

	Millions of yen	Thousands of U.S. dollars
	2014	2014
Service cost	¥ 3,311	\$ 32,171
Interest cost	2,282	22,173
Expected return on plan assets	(1,769)	(17,188)
Amortization:		
Actuarial loss	2,566	24,931
Past service cost	(184)	(1,788)
Retirement benefit expenses	¥ 6,206	\$ 60,299

(5) The amount of actuarial loss and past service cost recognized in other comprehensive income for the year before the deduction of the tax benefit is outlined as follows:

	Millions of yen	Thousands of U.S. dollars
	2014	2014
Actuarial loss	¥ 2,068	\$ 20,093
Past service cost	8	78
Total	¥ 2,076	\$ 20,171

(6) The balance of unrecognized actuarial loss and past service cost recognized in accumulated other comprehensive income before deduction of tax benefit is outlined as follows:

	Millions of yen	Thousands of U.S. dollars
	2014	2014
Unrecognized actuarial loss	¥ (17,084)	\$ (165,993)
Unrecognized past service cost	55	534
Total	¥ (17,029)	\$ (165,459)

(7) The plan assets by major category consist of the follows:

	2014
Equities	51.3%
Bonds	24.4
General accounts at life insurance companies	18.7
Other	5.6
Total	100.0%

The expected long-term rate of return on plan assets is determined as a result of consideration of both the portfolio allocation at present and in the future, and long-term expected rate of return from multiple plan assets.

(8) The assumptions used in accounting for the defined benefit plans are as follows:

	2014
Discount rate	Principally 1.5%
Expected long-term rate of return on plan assets	Principally 2.5%

3. Defined contribution pension plans for the year ended March 31, 2014

	Millions of yen	Thousands of U.S. dollars
	2014	2014
Contributions to defined contribution pension plans	¥ 1,290	\$ 12,534

4. Accrued retirement benefits for employees for the year ended March 31, 2013

The following table sets forth the funded and accrued status and the amounts recognized in the accompanying consolidated balance sheet at March 31, 2013 for the Company's and consolidated subsidiaries' defined benefit pension plans:

	Millions of yen
	2013
Retirement benefit obligation	¥ (110,526)
Plan assets at fair value	56,541
Unfunded retirement benefit obligation	(53,985)
Unrecognized actuarial loss	16,036
Unrecognized past service cost	103
Net retirement benefit obligation	(37,846)
Prepaid pension cost	34
Accrued retirement benefits for employees	¥ (37,880)

The components of retirement benefit expenses are outlined as follows:

	Millions of yen
	2013
Service cost	¥ 3,781
Interest cost	2,762
Expected return on plan assets	(1,496)
Amortization:	
Actuarial loss	2,208
Past service cost	(150)
Retirement benefit expenses	7,105
Contributions to defined contribution pension plans	1,203
Retirement benefit expenses	¥ 8,308

The assumptions used in accounting for the defined benefit plans are as follows:

	2013
Discount rate (*)	Principally 1.5%
Expected rate of return on plan assets	Principally 2.5%

*As a result of a review of discount rates by reference to bond market rates, the Company and its consolidated subsidiaries changed the discount rate as of March 31, 2013 to principally 1.5% from principally 2.6% as of April 1, 2012.

10. Shareholders' Equity

(a) The Corporation Law of Japan (the "Law") provides that an amount equal to 10% of the amount to be disbursed as distributions of capital surplus (other than the capital reserve) and retained earnings (other than the legal reserve) be transferred to the capital reserve and the legal reserve, respectively, until the sum of the capital reserve and the legal reserve equals 25% of the capital stock account. Such distributions can be made at any time by resolution of the shareholders or by the Board of Directors if certain conditions are met.

Retained earnings include the legal reserve provided in accordance with the provisions of the Law. The legal reserve of the Company included in retained earnings amounted to ¥8,639 million (\$83,939 thousand) at March 31, 2014 and 2013.

(b) Movements in shares issued and treasury stock during the years ended March 31, 2014 and 2013 are summarized as follows:

	Number of shares			
	2014			
	April 1, 2013	Increase	Decrease	March 31, 2014
Shares issued:Common stock	532,463,527	-	-	532,463,527
Treasury stock:Common stock	576,643	44,948	1,845	619,746
	2013			
	April 1, 2012	Increase	Decrease	March 31, 2013
Shares issued:Common stock	532,463,527	-	-	532,463,527
Treasury stock:Common stock	566,982	19,171	9,510	576,643

The increases in treasury stock were due to purchases of shares of less than one voting unit and the decreases in treasury stock were due to sales of shares at requests of shareholders owning less than one voting unit for the years ended March 31, 2014 and 2013.

Notes to Consolidated Financial Statements

March 31, 2014

11. Contingent Liabilities

Arbitration for claim of damages

NTN-SNR ROULEMENTS (hereinafter referred as NTN-SNR), a consolidated subsidiary, has been involved in arbitration proceedings since November 2012. One automotive customer submitted a claim to arbitration and requested the payment in the amount of \$57,774 thousand (¥5,946 million) for damages due to allegedly defective products provided by NTN-SNR.

With subsequent arbitration proceedings, the claim for damages has increased to \$62,864 thousand (¥6,470 million) related to these products. NTN-SNR continues to present counterarguments against this claim appropriately.

Depending on the results of the arbitration, the results of operations of the Company and its consolidated subsidiaries could be affected. However, it is currently difficult to make reasonable estimates of the future possible effects on the results of operations and financial position of the Company and its consolidated subsidiaries.

12. Finance Lease Transactions That Do Not Transfer Ownership

Lessees' accounting

The following *pro forma* amounts represent the acquisition costs, accumulated depreciation and net book value of property leased to the Company and its consolidated subsidiaries at March 31, 2014 and 2013, which would have been reflected in the accompanying consolidated balance sheets if finance leases other than those which transfer the ownership of the leased property to the Company and its consolidated subsidiaries (which are currently accounted for as operating leases) had been capitalized:

	Millions of yen					
	2014			2013		
	Acquisition costs	Accumulated depreciation	Net book value	Acquisition costs	Accumulated depreciation	Net book value
Buildings and structures	¥ 1,412	¥ 1,195	¥ 217	¥ 1,411	¥ 1,138	¥ 273
Machinery, equipment and vehicles	4	4	0	10	9	1
Other assets	12	11	1	16	13	3
	¥ 1,428	¥ 1,210	¥ 218	¥ 1,437	¥ 1,160	¥ 277

	Thousands of U.S. dollars		
	2014		
	Acquisition costs	Accumulated depreciation	Net book value
Buildings and structures	\$ 13,719	\$ 11,611	\$ 2,108
Machinery, equipment and vehicles	39	39	0
Other assets	117	107	10
	\$ 13,875	\$ 11,757	\$ 2,118

Lease payments relating to finance leases accounted for as operating leases in the accompanying consolidated financial statements amounted to ¥59 million (\$573 thousand) and ¥65 million for the years ended March 31, 2014 and 2013, respectively. Depreciation of the leased assets computed by the straight-line method over the respective lease terms with a nil residual value amounted to ¥59 million (\$573 thousand) and ¥65 million for the years ended March 31, 2014 and 2013, respectively.

Future minimum lease payments subsequent to March 31, 2014 for finance leases accounted for as operating leases are summarized as follows:

Year ending March 31,	Millions of yen	Thousands of U.S. dollars
2015	¥ 58	\$ 563
2016 and thereafter	160	1,555
Total	¥ 218	\$ 2,118

The acquisition costs and future minimum lease payments under finance leases presented in the above tables include the imputed interest expense. No loss on impairment was allocated to any leased assets for the years ended March 31, 2014 and 2013.

13. Operating Leases

Future minimum lease payments subsequent to March 31, 2014 for non-cancelable operating leases were as follows:

Year ending March 31,	Millions of yen	Thousands of U.S. dollars
2015	¥ 790	\$ 7,676
2016 and thereafter	4,074	39,584
Total	¥ 4,864	\$ 47,260

14. Financial Instruments – Fair Value

Overview

(a) Policy for financial instruments

The Company and its subsidiaries (collectively, the “Group”) raise necessary funds in accordance with management plans mainly by bank borrowings in support of operations related to the manufacture and sales of bearings, constant-velocity joints (CVJs) and precision equipments. The Group utilizes bank borrowings for short-term operating funds, and bank borrowings for long-term capital investments and finances. Temporary surplus funds are managed by low-risk financial assets. The Group utilizes derivatives to avoid or mitigate risks as described in the later part of this note and does not hold them for speculative purposes.

(b) Types of financial instruments and related risks

Trade receivables, notes and accounts receivable, are exposed to credit risk of customers. In addition, as a result of the business of the Group, which operates globally, foreign currency trade receivables are exposed to currency rate fluctuation risk, which is mitigated by utilizing forward foreign currency exchange contracts. Securities are mainly composed of stocks of the companies with which the Group has business relationships and they are exposed to fluctuation risk of market prices.

Trade payables, notes and accounts payable, are due within one year. Certain trade payables resulting from the import of raw materials are denominated in foreign currencies. These are exposed to fluctuation risk of foreign currencies. However, the risk is mitigated because the trade payables, notes and accounts payable denominated in foreign currencies are within the range of accounts receivable denominated in the same currencies.

Loans are mainly utilized for business operations of the Group. Short-term loans are mainly utilized for financing of operating activities. Long-term loans are mainly utilized for capital investments and financing. These have maturity dates of less than 10 years, at the longest, subsequent to March 31, 2014. Certain loans are exposed to fluctuation risk of interest rates and fluctuation risk of exchange rates and this risk is hedged by derivative transactions of interest rate swap agreements and cross currency swap agreements.

The Group has a policy to utilize derivative transactions involving forward foreign currency exchange contracts, currency option agreements, currency swap agreements, interest rate swap agreements and interest rate option agreements for the purpose of avoiding future fluctuation risk of foreign currencies trade receivables and payables and mitigating future fluctuation risk of interest rate of loans and corporate bonds. The Group utilized forward foreign currency exchange contracts, interest rate swap agreements and cross currency swap agreements for the year ended March 31, 2014. Refer to “(p) Derivative financial instruments and hedging activities” in Note 2. “Summary of Significant Accounting Policies.”

(c) Risk management for financial instruments

(i) Monitoring of credit risk (the risk that customers or counterparties may default)

In accordance with internal rules and manual, the credit management section periodically monitors financial conditions of major customers, manages collection due dates and balances of each customer and tries to identify credit risk of customers with worsening financial conditions at the early stage and mitigate the risk. Credit risk of securities is quite

low because the Group utilizes certificate of deposits with high credit ratings, up to a limited amount, which is approved by the Company. The Group believes credit risk of derivative transactions is almost nil because counterparties are financial institutions with high credit ratings.

(ii) Monitoring of market risks (the risks arising from fluctuations in foreign currency exchange rates, interest rates and others)

The Group mainly utilizes forward foreign currency exchange contracts for hedging of fluctuation risk which is identified by each currency. Depending on the market conditions of foreign currencies, the Group utilizes forward foreign currency exchange contracts for forecasted export transactions with a maximum period of 6 months.

The Group utilizes interest rate swap agreements and cross currency swap agreements to mitigate fluctuation risk of interest rates and fluctuation risk of loans principal due to floating exchange rates.

The Group continuously reviews securities holdings by monitoring periodically the market value and financial condition of securities’ issuers (companies with business relationships with the Group) and by evaluating those relationships.

The Group has established policies which include maximum upper limits and reporting obligations for derivative transactions and comply fully with these guidelines. Derivative transactions are entered into by the Company’s Accounting Department and certain consolidated subsidiaries. The Company carries out mutual supervision and monitoring of the derivative transactions in accordance with management policies and its consolidated subsidiaries apply the same approach. Each derivative transaction of the Company is reported to the responsible director when entered into. The consolidated subsidiaries are required to report the status of their derivatives transactions to the Company on a monthly basis and are also required to consult with the Company when they enter into derivative transactions other than forward foreign currency exchange contracts.

(iii) Monitoring of liquidity risk (the risk that the Group may not be able to meet its obligations on scheduled due dates)

The Group manages liquidity risk with the responsible section preparing and updating cash flow plans and keeping necessary funds based on reports of each section.

Syndicated loans have certain financial covenants that represent a liquidity risk from an early repayment request by financial institutions.

(iv) Supplementary explanation of the fair value of financial instruments
The fair value of financial instruments is based on their quoted market price, if available. When there is no quoted market price available, fair value is reasonably estimated. Since various assumptions and factors are reflected in estimating the fair value, different assumptions and factors could result in different fair value. In addition, the notional amounts of derivatives in Note 15 “Derivative Financial Instruments and Hedging Activities” are not necessarily indicative of the actual market risk involved in the derivative transactions.

Fair Value of Financial Instruments

The carrying value of financial instruments on the consolidated balance sheets, fair value and the difference as of March 31, 2014 and 2013, are shown in the following table. The table does not include financial instruments for which it is extremely difficult to determine the fair value. (Please refer to Note 2 below).

	Millions of yen					
	2014			2013		
	Carrying value	Fair value	Difference	Carrying value	Fair value	Difference
(1) Cash and cash equivalents	¥ 129,671	¥ 129,671	¥ –	¥ 86,100	¥ 86,100	¥ –
(2) Short-term investments	1,076	1,076	–	692	692	–
(3) Trade receivables	135,358	135,358	–	118,612	118,612	–
(4) Investment securities	28,908	28,913	5	25,278	25,282	4
(5) Short-term loans receivable included in other current assets	29	29	–	310	310	–
Total assets	¥ 295,042	¥ 295,047	¥5	¥ 230,992	¥ 230,996	¥ 4
(6) Short-term bank loans	100,756	100,756	–	105,706	105,706	–
(7) Current portion of long-term debt	28,992	28,992	–	64,715	64,745	30
(8) Trade payables	106,410	106,410	–	88,459	88,459	–
(9) Accrued income taxes	3,424	3,424	–	1,485	1,485	–
(10) Long-term debt	252,019	251,787	(232)	190,381	192,191	1,810
Total liabilities	¥ 491,601	¥ 491,369	¥ (232)	¥ 450,746	¥ 452,586	¥ 1,840
Derivative transactions (*)	¥ (30)	¥ (30)	¥ –	¥ (1,449)	¥ (1,449)	¥ –

Notes to Consolidated Financial Statements

March 31, 2014

Thousands of U.S. dollars			
2014			
	Carrying value	Fair value	Difference
(1) Cash and cash equivalents	\$ 1,259,920	\$ 1,259,920	\$ –
(2) Short-term investments	10,455	10,455	–
(3) Trade receivables	1,315,177	1,315,177	–
(4) Investment securities	280,878	280,927	49
(5) Short-term loans receivable included in other current assets	282	282	–
Total assets	\$ 2,866,712	\$ 2,866,761	\$49
(6) Short-term bank loans	978,974	978,974	–
(7) Current portion of long-term debt	281,694	281,694	–
(8) Trade payables	1,033,910	1,033,910	–
(9) Accrued income taxes	33,269	33,269	–
(10) Long-term debt	2,448,688	2,446,434	(2,254)
Total liabilities	\$ 4,776,535	\$ 4,774,281	\$ (2,254)
Derivative transactions (*)	\$ (291)	\$ (291)	\$ –

* Assets and liabilities arising from derivative transactions are shown at net value with the amount in parentheses representing net liability position.

Note 1: Methods to determine the fair value of financial instruments and other matters related to securities and derivative transactions

(1) Cash and cash equivalents, (2) Short-term investments, (3) Trade receivables and (5) Short-term loans receivable included in other current assets

Since these items are settled in a short time period, their carrying value approximates fair value.

(4) Investment securities

The fair value of equity securities is based on quoted market prices.

(6) Short-term bank loans, (8) Trade payables and (9) Accrued income taxes

Since these items are settled in a short time period, their carrying value approximates fair value.

(7) Current portion of long-term debt and (10) Long-term debt

Long-term debt is composed of corporate bonds and long-term loans. The fair market value of corporate bonds is based on quoted market prices. The fair value of long-term debt is based on the present value of the total of principal and interest discounted by the interest rate to be applied assuming new loans under the similar conditions to existing loans are made.

Certain long-term loans with floating interest rates were hedged by interest rate swap agreements and accounted for as loans with fixed interest rates. The fair value of those long-term loans is based on the present value of the total of principals, interest payments and net cash flows of the swap agreements discounted by the interest rates to be applied assuming new loans under similar conditions are made.

Derivative Transactions

Please refer to Note 15 “Derivative Financial Instruments and Hedging Activities” section of these Notes to Consolidated Financial Statements.

Note 2: Financial instruments for which it is extremely difficult to determine the fair value were as follows:

	Millions of yen		Thousands of U.S. dollars
	2014	2013	2014
Unlisted stocks			
Stocks of subsidiaries and affiliates	¥ 15,540	¥ 13,690	\$ 150,991
Other	287	285	2,789
Unlisted foreign bonds	1,218	1,038	11,834
Unlisted domestic bonds	1,000	1,000	9,716
Total	¥ 18,045	¥ 16,013	\$ 175,330

Because no quoted market price is available and it is extremely difficult to determine the fair value, the above financial instruments are not included in the preceding table.

Note 3: Redemption schedule for cash and cash equivalents, receivables and marketable securities with maturities at March 31, 2014 and 2013 is as follows:

	Millions of yen			
	2014			
	Within one year	More than one year and within five years	More than five years and within ten years	More than ten years
Cash and cash equivalents	¥ 129,671	¥ –	¥ –	¥ –
Short-term investments	2,076	–	–	–
Trade receivables	135,358	–	–	–
Short-term loans receivable included in other current assets	29	–	–	–
Total	¥ 267,134	¥ –	¥ –	¥ –
	Millions of yen			
	2013			
	Within one year	More than one year and within five years	More than five years and within ten years	More than ten years
Cash and cash equivalents	¥ 86,100	¥ –	¥ –	¥ –
Short-term investments	692	–	–	–
Trade receivables	118,612	–	–	–
Short-term loans receivable included in other current assets	310	–	–	–
Total	¥ 205,714	¥ –	¥ –	¥ –

Thousands of U.S. dollars

	2014			
	Within one year	More than one year and within five years	More than five years and within ten years	More than ten years
Cash and cash equivalents	\$ 1,259,920	\$ -	\$ -	\$ -
Short-term investments	20,171	-	-	-
Trade receivables	1,315,177	-	-	-
Short-term loans receivable included in other current assets	282	-	-	-
Total	\$ 2,595,550	\$ -	\$ -	\$ -

Note 4: The redemption schedule for long-term debt is disclosed in Note 8 "Short-Term Bank Loans, Long-Term Debt and Lease Obligations" section of these Notes to Consolidated Financial Statements.

15. Derivative Financial Instruments and Hedging Activities

(a) Derivative transactions to which hedge accounting is not applied

The estimated fair value of the derivatives positions outstanding which do not qualify for deferral hedge accounting at March 31, 2014 and 2013 is summarized as follows:

Currency-related transactions

Classification	Transaction	Millions of yen		
		Notional amount	Fair value	Valuation gain (loss)
	Forward foreign currency exchange contracts			
	Selling:			
	U.S. Dollars	¥ 4,464	¥ 5	¥ 5
	Euro	6,402	(38)	(38)
	Thai Baht	466	1	1
Over-the-counter transactions	Canadian Dollars	74	0	0
	British Pounds	120	0	0
	Buying:			
	U.S. Dollars	16	0	0
	Euro	281	2	2
	Total	¥ 11,823	¥ (30)	¥ (30)

Classification	Transaction	Millions of yen		
		Notional amount	Fair value	Valuation (loss)
	Forward foreign currency exchange contracts			
	Selling:			
	U.S. Dollars	¥ 14,846	¥ (1,072)	¥ (1,072)
	Euro	7,460	(228)	(228)
Over-the-counter transactions	Thai Baht	1,706	(129)	(129)
	Canadian Dollars	285	(5)	(5)
	British Pounds	197	0	0
	Buying:			
	Yen	608	(15)	(15)
	Total	¥ 25,102	¥ (1,449)	¥ (1,449)

Classification	Transaction	Thousands of U.S. dollars		
		Notional amount	Fair value	Valuation gain (loss)
	Forward foreign currency exchange contracts			
	Selling:			
	U.S. Dollars	\$ 43,374	\$ 49	\$ 49
	Euro	62,204	(369)	(369)
Over-the-counter transactions	Thai Baht	4,528	10	10
	Canadian Dollars	719	0	0
	British Pounds	1,166	0	0
	Buying:			
	U.S. Dollars	155	0	0
	Euro	2,730	19	19
	Total	\$ 114,876	\$ (291)	\$ (291)

The fair value of forward foreign currency exchange contracts are computed using prices provided by counterparty financial institutions. There are no contracts to be settled after one year.

Notes to Consolidated Financial Statements

March 31, 2014

(b) Derivative transactions to which hedge accounting is applied

The estimated fair value of the derivatives positions outstanding which qualify for deferral hedge accounting at March 31, 2014 and 2013 is summarized as follows.

Interest-rate related transactions

		Millions of yen		
		2014		
		Contractual value		
Method of hedge accounting	Transaction	Notional amount	More than one year	Fair value
Swap rates applied to underlying long-term debt	Interest rate swaps Receive / floating and pay / fixed	¥ 27,000	¥ 27,000	(*)

		Millions of yen		
		2013		
		Contractual value		
Method of hedge accounting	Transaction	Notional amount	More than one year	Fair value
Swap rates applied to underlying long-term debt	Interest rate swaps Receive / floating and pay / fixed	¥ 37,000	¥ 19,000	(*)

		Thousands of U.S. dollars		
		2014		
		Contractual value		
Method of hedge accounting	Transaction	Notional amount	More than one year	Fair value
Swap rates applied to underlying long-term debt	Interest rate swaps Receive / floating and pay / fixed	\$ 262,340	\$ 262,340	(*)

* Because interest rate swap agreements are accounted for applying swap rates to underlying long-term debt, their fair value is included in that of long-term debt disclosed in Note 14.

Interest-rate and currency related transactions

		Millions of yen		
		2014		
		Contractual value		
Method of hedge accounting	Transaction	Notional amount	More than one year	Fair value
Swap rates and currency applied to underlying long-term debt	Cross currency swaps Receive / floating US\$ and pay / fixed yen	¥ 1,500	¥ 1,500	(*)

		Thousands of U.S. dollars		
		2014		
		Contractual value		
Method of hedge accounting	Transaction	Notional amount	More than one year	Fair value
Swap rates and currency applied to underlying long-term debt	Cross currency swaps Receive / floating US\$ and pay / fixed yen	\$ 14,574	\$ 14,574	(*)

* Because interest rate swap agreements and cross currency swap agreements are accounted for applying swap rates to underlying long-term debt, their fair value is included in that of long-term debt disclosed in Note 14.

16. Research and Development Costs

Research and development costs included in cost of sales and selling, general and administrative expenses totalled ¥17,821 million (\$173,154 thousand) and ¥16,174 million for the years ended March 31, 2014 and 2013, respectively.

17. Loss on Surcharge Payments under Anti-Monopoly Act

The Company and certain consolidated subsidiaries in Europe received a notice from European Commission regarding the imposition of surcharges due to violations of EU Competition Law related to the automotive bearings business in Europe. Based on the notice from the European Commission, loss on surcharge payments under the Anti-Monopoly Act in the amount of €201,354 thousand or ¥27,024 million (\$262,573 thousand), at the average exchange rate for the year ended March 31, 2014, was recorded. This decision was made through the settlement process with the European Commission based on relevant laws.

18. Provision for Loss on Support to a Related Company

The Company's related company in the Americas received a payment notice in connection with claims involving inappropriate import procedures in prior years. As a result, the liabilities of this related company were in excess of assets. Provision for loss on support to a related company in the amount of ¥1,600 million (\$15,546 thousand) was recorded for the year ended March 31, 2014.

19. Reorganization Expenses

Reorganization expenses for the years ended March 31, 2014 and 2013 consisted of the following:

	Millions of yen		Thousands of U.S. dollars
	2014	2013	2014
Restructuring in the production system in its consolidated subsidiaries	¥ 1,421	¥ –	\$ 13,807
Expenses for soil improvement work for TAKARAZUKA Works	–	2,600	–
Others	–	427	–
	¥ 1,421	¥ 3,027	\$ 13,807

* Loss on impairment of fixed assets in the amount of ¥184 million (\$1,788 thousand) and ¥145 million for the years ended March 31, 2014 and 2013 were included above respectively.

20. Restructuring Costs

Restructuring costs for the years ended March 31, 2014 and 2013 consisted of the following:

	Millions of yen		Thousands of U.S. dollars
	2014	2013	2014
Expense for employees' early retirement incentive plans	¥ 301	¥ –	\$ 2,925
Provision for employees' early retirement incentive plans	–	5,911	–
Loss on valuation of assets due to the partial discontinuation of operations for precision equipment	–	356	–
Others	–	98	–
	¥ 301	¥ 6,365	\$ 2,925

21. Provision for Surcharge Payments under Anti-Monopoly Act

The Company and its consolidated subsidiary in Singapore have been under investigation by the Competition Commission Singapore over suspicions of violations of Singaporean Competition Law in connection with the bearings business involving Singaporean customers. With the progress of the investigations, the Company estimated the amount of loss expected in the future, and recorded a provision for surcharge payments under the Anti-Monopoly Act in the amount ¥35 million (\$340 thousand) for the year ended March 31, 2014.

Based on an order from the Japan Fair Trade Commission (the "JFTC"), the Company recorded a provision for surcharge payments under the Anti-Monopoly Act in the amount of ¥7,231 million for the year ended March 31, 2013.

22. Other Comprehensive Income (Loss)

The following table presents the analysis of other comprehensive income (loss) for the years ended March 31, 2014 and 2013.

	Millions of yen		Thousands of U.S. dollars
	2014	2013	2014
Net unrealized holding gain (loss) on securities:			
Amount arising during the year	¥ 5,676	¥ 2,304	\$ 55,150
Reclassification adjustments for (gains) losses included in net loss	(1,272)	488	(12,359)
Before tax effect	4,404	2,792	42,791
Tax effect	(1,541)	(977)	(14,973)
Total	2,863	1,815	27,818
Translation adjustments:			
Amount arising during the year	15,378	19,484	149,417
Reclassification adjustments for losses included in net loss	–	18	–
Before tax effect	15,378	19,502	149,417
Tax effect	–	–	–
Total	15,378	19,502	149,417
Retirement benefit liability adjustments:			
Amount arising during the year	2,296	(2,018)	22,309
Reclassification adjustments for losses included in net loss	718	603	6,976
Before tax effect	3,014	(1,415)	29,285
Tax effect	(1,193)	323	(11,591)
Total	1,821	(1,092)	17,694
Share of other comprehensive income of affiliates accounted for by the equity method:			
Amount arising during the year	1,980	1,581	19,238
Other comprehensive income, net	¥ 22,042	¥ 21,806	\$ 214,167

Notes to Consolidated Financial Statements

March 31, 2014

23. Income Taxes

Income taxes applicable to the Company and its domestic subsidiaries comprise corporate tax, inhabitants' taxes and enterprise tax which, in the aggregate, resulted in statutory tax rates of 37.4% for the years ended March 31, 2014 and 2013. Overseas subsidiaries are subject to the income taxes of the respective countries in which they operate.

The details of the differences between the statutory tax rate and effective tax rates for the years ended March 31, 2014 and 2013 are omitted because the Company and its consolidated subsidiaries recorded a loss before income taxes and minority interests for the year.

The tax effects of temporary differences which gave rise to significant portions of the deferred tax assets and liabilities at March 31, 2014 and 2013 are presented below:

	Millions of yen		Thousands of U.S. dollars
	2014	2013	2014
Deferred tax assets:			
Liability for retirement benefits	¥ 20,147	¥ –	\$ 195,754
Inventories	1,787	611	17,363
Tax loss carryforwards	14,567	21,359	141,537
Accrued expenses	3,044	2,036	29,576
Provision for employees' early retirement incentive plans	–	2,179	–
Accrued retirement benefits for employees	–	14,840	–
Other	8,688	8,221	84,416
Gross deferred tax assets	48,233	49,246	468,646
Less: valuation allowance	(5,011)	(4,565)	(48,689)
Total deferred tax assets	43,222	44,681	419,957
Deferred tax liabilities:			
Depreciation and amortization	(14,558)	(13,827)	(141,450)
Unrealized holding gain on securities	(4,347)	(2,806)	(42,237)
Reserve for deferred gain on property included in retained earnings	(550)	(561)	(5,344)
Retained earnings of overseas consolidated subsidiaries	(138)	(147)	(1,341)
Other	(2,178)	(2,307)	(21,161)
Total deferred tax liabilities	(21,771)	(19,648)	(211,533)
Net deferred tax assets	¥ 21,451	¥ 25,033	\$ 208,424

The "Act for Partial Amendment of the Income Tax Act, etc." (Act No. 10 of 2014) was promulgated on March 31, 2014 and, as a result, the Company is no longer subject to the Special Reconstruction Corporation Tax effective for years beginning on or after April 1, 2014.

In line with these revisions, the Company changed the statutory tax rate to calculate deferred tax assets and liabilities from 37.4% to 35.0% for temporary differences expected to be realized after April 1, 2014.

As a result of this change, net deferred tax assets (after netting deferred tax liabilities) decreased by ¥203 million (\$1,972 thousand), and income taxes – deferred increased by ¥203 million (\$1,972 thousand) as of and for the year ended March 31, 2014, respectively.

24. Amounts per Share

Amounts per share at March 31, 2014 and 2013 and for the years then ended were as follows:

	Yen		U.S. dollars
	2014	2013	2014
Net assets	¥ 374.68	¥ 375.84	\$ 3.64
Net loss:			
Basic	(27.54)	(26.69)	(0.27)
Cash dividends	2.00	–	0.02

Amounts per share of net assets are computed based on the number of shares of common stock outstanding at the year end.

Basic net loss per share is computed based on the net loss attributable to shareholders of common stock and the weighted-average number of shares of common stock outstanding during the year. Diluted net income per share has not been presented because there were no potentially dilutive shares of common stock for the years ended March 31, 2014 and 2013, and the Company and consolidated subsidiaries recorded net loss for the years ended March 31, 2014 and 2013.

Cash dividends per share represent the cash dividends proposed by the Board of Directors as applicable to the respective years together with the interim cash dividends paid.

25. Segment Information

1. Outline of reporting segments

The Group's reporting segments are divisions of the Group for which separate financial information is available, and whose operating results are reviewed regularly by the highest management decision-making body (the Board of Directors meeting of the Company) in order to allocate management resources and assess performance of operations.

The Group's main business lines consist of the manufacture and sales of bearings, CVJs and precision equipments for the aftermarket, general industrial machinery market, and automotive market. Business activities in Japan are controlled by the Company (the Head Office), and overseas business activities are controlled by the General Manager responsible in each region. Business entities in each region prepare their own plans and strategies to conduct business activities while analyzing profitability and the investment efficiency of operations.

Accordingly, the Group has four reporting segments based on geographic business segmentation controlled by the Head Office or the General Managers: Japan, the Americas, Europe, and Asia and other areas. Each reporting segment engages in the manufacture and sale of bearings, CVJs, and precision equipment and other products.

2. Calculation methods used for net sales, income or loss, assets, liabilities and other items on each reporting segment

The accounting policies of the segments are substantially the same as those described in the significant accounting policies in Note 2. Inter-segment sales and transfer are recorded at the same prices used in transactions with third parties.

3. Information as to net sales, income or loss, assets, liabilities, and other items for each reporting segment for the years ended March 31, 2014 and 2013.

Reportable segment information for the years ended March 31, 2014 and 2013 are summarized as follows:

	Millions of yen						
	2014						
	Reporting segments					Adjustments	Consolidated
Japan	Americas	Europe	Asia and other areas	Total			
Sales, income and assets or liabilities by reporting segments:							
Net sales:							
Sales to third parties	¥ 190,819	¥ 167,899	¥ 175,423	¥ 104,830	¥ 638,971	¥ –	¥ 638,971
Inter-segment sales and transfers	132,763	3,944	6,927	8,977	152,611	(152,611)	–
Total	323,582	171,843	182,350	113,807	791,582	(152,611)	638,971
Segment income	¥ 25,594	¥ 2,645	¥ 2,139	¥ 4,405	¥ 34,783	¥ (1,779)	¥ 33,004
Segment assets	¥ 487,759	¥ 164,059	¥ 171,366	¥ 145,870	¥ 969,054	¥ (121,017)	¥ 848,037
Segment liabilities	¥ 385,748	¥ 124,918	¥ 125,812	¥ 54,989	¥ 691,467	¥ (56,799)	¥ 634,668
Other items:							
Depreciation and amortization	¥ 17,013	¥ 9,338	¥ 7,141	¥ 5,823	¥ 39,315	¥ –	¥ 39,315
Capital expenditures	¥ 9,684	¥ 9,648	¥ 7,303	¥ 8,375	¥ 35,010	¥ (5)	¥ 35,005

	Millions of yen						
	2013						
	Reporting segments					Adjustments	Consolidated
Japan	Americas	Europe	Asia and other areas	Total			
Sales, income and assets or liabilities by reporting segments:							
Net sales:							
Sales to third parties	¥ 193,491	¥ 135,385	¥ 132,177	¥ 78,542	¥ 539,595	¥ –	¥ 539,595
Inter-segment sales and transfers	122,442	3,093	4,367	7,220	137,122	(137,122)	–
Total	315,933	138,478	136,544	85,762	676,717	(137,122)	539,595
Segment income (loss)	¥ 9,837	¥ (3,218)	¥ (214)	¥ 714	¥ 7,119	¥ 159	¥ 7,278
Segment assets	¥ 472,374	¥ 151,710	¥ 133,042	¥ 131,394	¥ 888,520	¥ (120,058)	¥ 768,462
Segment liabilities	¥ 359,873	¥ 116,160	¥ 78,327	¥ 51,840	¥ 606,200	¥ (49,481)	¥ 556,719
Other items:							
Depreciation and amortization	¥ 18,789	¥ 7,094	¥ 5,325	¥ 3,633	¥ 34,841	¥ –	¥ 34,841
Capital expenditures	¥ 13,689	¥ 14,665	¥ 7,245	¥ 15,019	¥ 50,618	¥ (103)	¥ 50,515

	Thousands of U.S. dollars						
	2014						
	Reporting segments					Adjustments	Consolidated
Japan	Americas	Europe	Asia and other areas	Total			
Sales, income and assets or liabilities by reporting segments:							
Net sales:							
Sales to third parties	\$ 1,854,052	\$ 1,631,354	\$ 1,704,460	\$ 1,018,558	\$ 6,208,424	\$ –	\$ 6,208,424
Inter-segment sales and transfers	1,289,963	38,321	67,305	87,223	1,482,812	(1,482,812)	–
Total	3,144,015	1,669,675	1,771,765	1,105,781	7,691,236	(1,482,812)	6,208,424
Segment income	\$ 248,679	\$ 25,700	\$ 20,783	\$ 42,800	\$ 337,962	\$ (17,286)	\$ 320,676
Segment assets	\$ 4,739,205	\$ 1,594,044	\$ 1,665,041	\$ 1,417,314	\$ 9,415,604	\$ (1,175,835)	\$ 8,239,769
Segment liabilities	\$ 3,748,037	\$ 1,213,739	\$ 1,222,425	\$ 534,289	\$ 6,718,490	\$ (551,875)	\$ 6,166,615
Other items:							
Depreciation and amortization	\$ 165,303	\$ 90,731	\$ 69,384	\$ 56,578	\$ 381,996	\$ –	\$ 381,996
Capital expenditures	\$ 94,092	\$ 93,743	\$ 70,958	\$ 81,374	\$ 340,167	\$ (48)	\$ 340,119

The total amount of segment income is adjusted to operating income of the consolidated statements of operations.

Other than those corresponding to segment assets, adjustments relate to the elimination of inter-segment transactions. The adjustments for segment assets consist of inter-segment elimination of ¥222,460 million (\$2,161,484 thousand) and ¥193,691 million and the corporate assets of the group of ¥101,443 million (\$985,649 thousand) and ¥73,633 million for the years ended March 31, 2014 and 2013, respectively. The corporate assets are investments held by the Company, mainly cash and cash equivalents and investment securities.

Notes to Consolidated Financial Statements

March 31, 2014

4. Related information

(1) Sales by products and service

Sales by products and service classified by the similarity of the market for the years ended March 31, 2014 and 2013 are summarized as follows:

	Millions of yen			
	2014			
	Aftermarket	Industrial machinery	Automotive	Total
Sale to third parties	¥ 103,845	¥ 101,181	¥ 433,945	¥ 638,971

	Millions of yen			
	2013			
	Aftermarket	Industrial machinery	Automotive	Total
Sale to third parties	¥ 89,222	¥ 93,746	¥ 356,627	¥ 539,595

	Thousands of U.S. dollars			
	2014			
	Aftermarket	Industrial machinery	Automotive	Total
Sale to third parties	\$ 1,008,988	\$ 983,103	\$ 4,216,333	\$ 6,208,424

(2) Regional information

(a) Sales

Sales categorized by country and region based on locations of customers within the group for the years ended March 31, 2014 and 2013 are summarized as follows:

	Millions of yen				
	2014				
	Japan	Americas	Europe	Asia and other areas	Total
	¥ 179,082	¥ 174,566	¥ 166,280	¥ 119,043	¥ 638,971

	Millions of yen				
	2013				
	Japan	Americas	Europe	Asia and other areas	Total
	¥ 177,472	¥ 141,571	¥ 124,752	¥ 95,800	¥ 539,595

	Thousands of U.S. dollars				
	2014				
	Japan	Americas	Europe	Asia and other areas	Total
	\$ 1,740,012	\$ 1,696,133	\$ 1,615,624	\$ 1,156,655	\$ 6,208,424

"Americas" includes the U.S.A., Canada and Central and South America. Europe includes Germany, France, the U.K. and others. Asia and other areas include China, Thailand, India and others. The sales of the "Americas" segment above contain the sales to customers in U.S.A. of ¥149,677 million (\$1,454,304 thousand) and ¥122,435 million for the years ended March 31, 2014 and 2013, respectively.

(b) Property, plant and equipment

Property, plant and equipment categorized by country and region within the group at March 31, 2014 and 2013 are summarized as follows:

	Millions of yen				
	2014				
	Japan	Americas	Europe	Asia and other areas	Total
	¥ 117,027	¥ 79,148	¥ 52,286	¥ 60,930	¥ 309,391

	Millions of yen				
	2013				
	Japan	Americas	Europe	Asia and other areas	Total
	¥ 124,887	¥ 73,254	¥ 45,349	¥ 54,663	¥ 298,153

	Thousands of U.S. dollars				
	2014				
	Japan	Americas	Europe	Asia and other areas	Total
	\$ 1,137,068	\$ 769,024	\$ 508,026	\$ 592,013	\$ 3,006,131

1. Property, plant and equipment in "Americas" in the amount of ¥72,557 million (\$704,984 thousand) and ¥66,841 million is located in the U.S.A at March 31, 2014 and 2013, respectively.

2. Property, plant and equipment in "Europe" in the amount of ¥40,043 million (\$389,069 thousand) and ¥35,364 million is located in France at March 31, 2014 and 2013, respectively.

3. Property, plant and equipment in "Asia and other areas" in the amount of ¥46,812 million (\$454,839 thousand) and ¥40,719 million is located in China at March 31, 2014 and 2013, respectively.

5. Loss on impairment of fixed assets

Loss on impairment of fixed assets by reporting segment is summarized as follows:

Millions of yen				
2014				
Japan	Americas	Europe	Asia and other areas	Total
¥ 688	¥ 1,325	¥ 184	¥ –	¥ 2,197

Millions of yen				
2013				
Japan	Americas	Europe	Asia and other areas	Total
¥ 1,285	¥ 191	¥ 670	¥ 692	¥ 2,838

Thousands of U.S. dollars				
2014				
Japan	Americas	Europe	Asia and other areas	Total
\$ 6,685	\$ 12,874	\$ 1,788	\$ –	\$ 21,347

6. Significant gain on bargain purchase

The Company increased its ownership in NTN-SNR ROULEMENTS, a consolidated subsidiary, to 100% by acquiring an additional 17.7% ownership interest on March 27, 2013. This resulted in gain on bargain purchase in the amount of ¥1,929 million recorded in the "Japan" segment.

26. Sales of Fixed Assets

The Company approved a resolution on the sale of the site of the Takarazuka Works to Takarazuka City and a third party at the Board of Directors' meeting held on October 22, 2013. However, subsequently, the Company approved a resolution on the suspension of the sale of the site to the third party at the Board of Directors' meeting held on November 27, 2013.

The Company then negotiated with a new party to sell the property and agreed on the sales conditions. On December 26, 2013, the Company approved a resolution on the sale of the site to the new party at the Board of Directors' meeting. The details of the sale are as follows:

(1) Reason for sale

For more effective utilization of assets and an enhancement of asset efficiency, the Company had planned to sell the site of the Takarazuka Works after soil improvement. Then, the Company negotiated with purchasers and reached an agreement on the sales conditions.

(2) Details of Asset

Location and details	Gain on sale (*)	Current status
1-1 Toyo-cho, Takarazuka city, Hyogo Prefecture 86,800.02 square meters	Approximately, ¥6,700 million (\$65,099 thousand)	Unused site of former Takarazuka Works

Under the confidentiality obligation required by agreement with the purchaser, the Company cannot disclose the sale price and book value of the site.

(*) Gain on sale represents an approximate amount of proceeds on sales less estimated costs and expenses of the transaction.

(3) Information about purchasers

The purchasers are Takarazuka City and a general business entity operating in Japan. Under the confidentiality obligation required by the agreement with the purchaser, the Company cannot disclose the name of this general business entity. There are no capital, personal, or business relationships between the Company and the general business entity.

(4) Future forecast

Upon the sale of the fixed asset, the Company expects to record a gain on sales of fixed assets in the amount of ¥6,700 million (\$65,099 thousand). However, this was not included in the Company's consolidated statement of operations for the year ended March 31, 2014 and it will be recorded during the year ending March 31, 2017 because the asset is scheduled to be transferred in April 2016.



Ernst & Young ShinNihon LLC

Independent Auditor's Report

The Board of Directors
NTN Corporation

We have audited the accompanying consolidated financial statements of NTN Corporation and its consolidated subsidiaries, which comprise the consolidated balance sheet as at March 31, 2014, and the consolidated statements of operations, comprehensive income, changes in net assets, and cash flows for the year then ended and a summary of significant accounting policies and other explanatory information, all expressed in Japanese yen.

Management's Responsibility for the Consolidated Financial Statements

Management is responsible for the preparation and fair presentation of these consolidated financial statements in accordance with accounting principles generally accepted in Japan, and for designing and operating such internal control as management determines is necessary to enable the preparation and fair presentation of the consolidated financial statements that are free from material misstatement, whether due to fraud or error.

Auditor's Responsibility

Our responsibility is to express an opinion on these consolidated financial statements based on our audit. We conducted our audit in accordance with auditing standards generally accepted in Japan. Those standards require that we plan and perform the audit to obtain reasonable assurance about whether the consolidated financial statements are free from material misstatement.

An audit involves performing procedures to obtain audit evidence about the amounts and disclosures in the consolidated financial statements. The procedures selected depend on the auditor's judgment, including the assessment of the risks of material misstatement of the consolidated financial statements, whether due to fraud or error. The purpose of an audit of the consolidated financial statements is not to express an opinion on the effectiveness of the entity's internal control, but in making these risk assessments the auditor considers internal controls relevant to the entity's preparation and fair presentation of the consolidated financial statements in order to design audit procedures that are appropriate in the circumstances. An audit also includes evaluating the appropriateness of accounting policies used and the reasonableness of accounting estimates made by management, as well as evaluating the overall presentation of the consolidated financial statements.

We believe that the audit evidence we have obtained is sufficient and appropriate to provide a basis for our audit opinion.

Opinion

In our opinion, the consolidated financial statements referred to above present fairly, in all material respects, the consolidated financial position of NTN Corporation and its consolidated subsidiaries as at March 31, 2014, and their consolidated financial performance and cash flows for the year then ended in conformity with accounting principles generally accepted in Japan.

Convenience Translation

We have reviewed the translation of these consolidated financial statements into U.S. dollars, presented for the convenience of readers, and, in our opinion, the accompanying consolidated financial statements have been properly translated on the basis described in Note 1.

June 26, 2014
Osaka, Japan

Ernst & Young Shin Nihon LLC

Investor Information

As of March 31, 2014

Head Office

NTN Corporation
3-17, 1-chome, Kyomachibori, Nishi-ku,
Osaka 550-0003, Japan

Investor Relations

Corporate Communications Dept.
Phone: +81-6-6449-3528
Fax: +81-6-6443-3226
E-mail: irmanager@ntn.co.jp

NTN on the Internet

NTN's Website offers a variety of corporate and product information, including the latest annual report and financial results.
<http://www.ntn.co.jp>

Common Stock (As of March 31, 2014)

Authorized 1,800,000,000 shares
Issued and outstanding
532,463,527 shares

Number of Shareholders

(As of March 31, 2014)
27,768

Transfer Agent for Common Stock

Mitsubishi UFJ Trust Banking Corporation
4-5, 1-chome, Marunouchi,
Chiyoda-ku,
Tokyo 100-8212, Japan

Stock Exchange Listings

First Section of Tokyo Stock Exchange (#6472)

Independent Accountants

Ernst & Young ShinNihon LLC

General Meeting of Shareholders

The General Meeting of Shareholders was held on June 25, 2014 in Osaka

Stock Price Range in the Fiscal Year Ended March 31, 2014

High: ¥537
Low: ¥218

Shareholders by Category

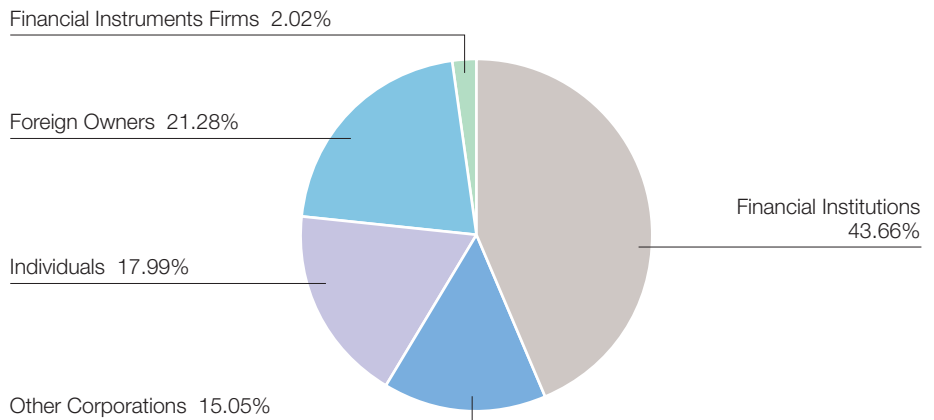

Tokyo Stock Price Range

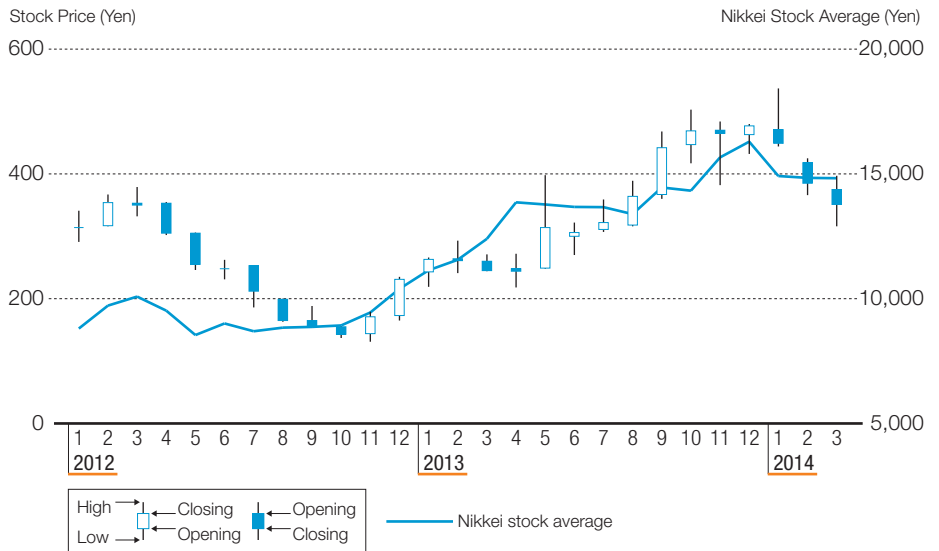

Monthly Volume Traded (Million Shares)

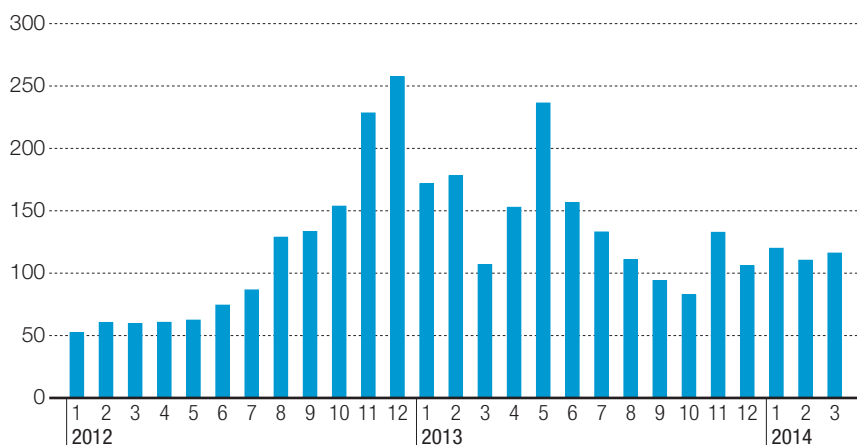

Global Network

As of March 31, 2014

Consolidated Subsidiaries	Paid-in Capital	Holding as percentage (%)
Consolidated Subsidiaries		
1 NTN BEARING SERVICE CORPORATION	¥480,000,000	100
2 NTN KONGO CORP.	¥1,000,000,000	100
3 NTN ENGINEERING PLASTICS CORP.	¥100,000,000	100
4 NTN POWDER METAL CORP.	¥400,000,000	100
5 NTN MIKUMO COMPANY LTD.	¥450,000,000	100
6 NTN CASTING CORP.	¥450,000,000	100
7 NTN KINAN CORP.	¥450,000,000	100
8 NTN MIE CORP.	¥3,000,000,000	100
9 NTN OMAEZAKI CORP.	¥266,000,000	97.4
10 NTN KAMIINA CORP.	¥725,000,000	80
11 NTN FUKUROI CORP.	¥1,500,000,000	100
12 NTN HOUDATSU SHIMIZU CORP.	¥1,250,000,000	100
13 NTN AKAIWA CORP.	¥1,250,000,000	100
14 NTN NOTO CORP.	¥1,000,000,000	100
15 NIPPON KAGAKU YAKIN CO., LTD.	¥100,000,000	98.1
16 NTN Technical Service Corp.	¥200,000,000	100
17 NTN LOGISTICS CO.,LTD.	¥10,000,000	100 (100)
18 NTN USA CORP.	US. \$131,120,000	100
19 NTN BEARING CORP. OF AMERICA	US. \$24,700,000	100 (100)
20 NTN DRIVESHAFT,INC.	US. \$54,580,000	100 (100)

Consolidated Subsidiaries	Paid-in Capital	Holding as percentage (%)
21 AMERICAN NTN BEARING MFG.CORP.	US. \$24,330,000	100 (100)
22 NTN-BOWER CORP.	US. \$67,000,000	100 (100)
23 NTK PRECISION AXLE CORP.	US. \$15,000,000	60 (60)
24 NTA PRECISION AXLE CORP.	US. \$20,000,000	62.5 (62.5)
25 NTN BEARING CORP. OF CANADA LTD.	CAN. \$20,100,000	100
26 NTN-SUDAMERICANA, S.A.	US. \$700,000	100
27 NTN Driveshaft do Brasil	BRL 79,479,763	100 (13.37)
28 NTN MANUFACTURING DE MEXICO,S.A.DE C.V.	Mex. \$ 66,105,190	100 (5)
29 NTN Waelzlager (Europa) GmbH	EURO 14,500,000	100
30 NTN Kugellagerfabrik (Deutschland) G.m.b.H	EURO 18,500,000	100
31 NTE Gardelegen G.m.b.H.	EURO 1,500,000	100
32 NTN Antriebstechnik GmbH	EURO 50,000	75
33 NTN BEARINGS (UK) LTD.	STG. £2,600,000	100 (0.04)
34 NTN TRANSMISSIONS EUROPE	EURO 76,531,592	100
35 NTN TRANSMISSIONS EUROPE CREZANCY	EURO 9,000,000	100 (100)
36 NTN MANİSA OTOMOTİV LİMİTED ŞİRKETİ	TRY 12,000,000	100 (1)

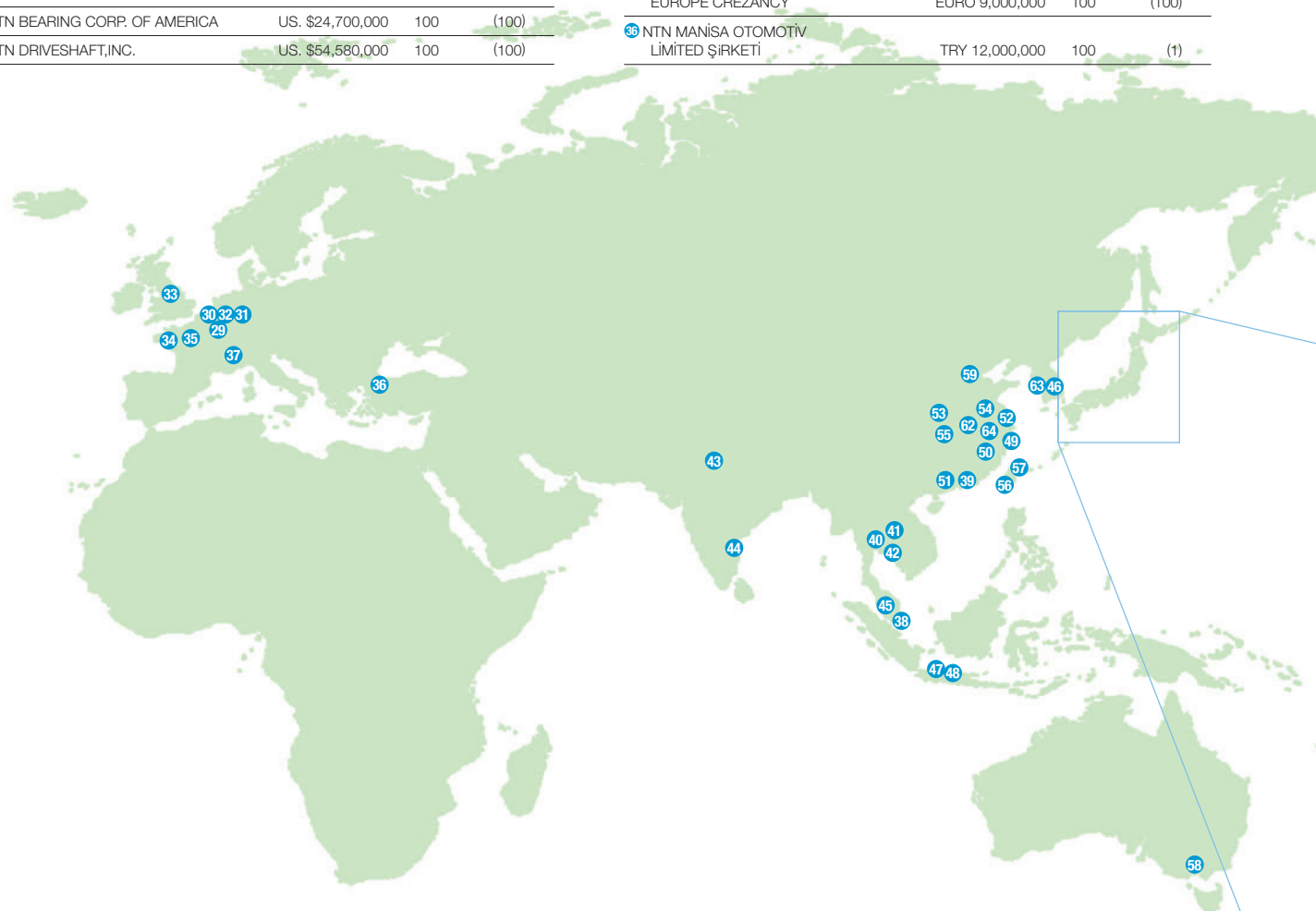

Consolidated Subsidiaries	Paid-in Capital	Holding as percentage (%)	
37 NTN-SNR ROULEMENTS	EURO11,359,542	100	
38 NTN BEARING-SINGAPORE (PTE) LTD.	S. \$36,000,000	100	(0.969)
39 NTN CHINA LTD.	HK. \$2,500,000	100	
40 NTN BEARING-THAILAND CO.,LTD.	BAHT780,000,000	100	(99.999)
41 NTN MANUFACTURING (THAILAND) CO.,LTD.	BAHT1,311,000,000	100	(99.999)
42 NTPT CO.,LTD.	BAHT 600,000,000	75	(0.02)
43 NTN NEI Manufacturing India Private LTD.	INR 3,238,000,000	96.14	(0.002)
44 NTN BEARING INDIA PRIVATE LTD.	INR 300,000,000	100	(0.1)
45 NTN BEARING-MALAYSIA SDN.BHD.	M. \$10,000,000	60	(60)
46 NTN KOREA CO.,LTD.	WON500,000,000	100	
47 PT. NTN BEARING INDONESIA	US. \$7,300,000	100	(100)
48 PT. NTN MANUFACTURING INDONESIA	US. \$17,250,000	100	(0.006)
49 NTN (CHINA) Investment Corp.	US. \$224,160,000	100	
50 Shanghai NTN Corp.	US. \$166,500,000	95	(15.72)
51 Guangzhou NTN-Yulon Drivetrain Co., Ltd.	US. \$12,500,000	60	(12)

Consolidated Subsidiaries	Paid-in Capital	Holding as percentage (%)	
52 NTN-RAB (Changzhou) Corp.	US. \$28,440,000	100	
53 NTN-LYC (Luoyang) Bearing Corp.	US. \$73,800,000	50	(50)
54 Nanjing NTN Corp.	US. \$160,000,000	100	(85)
55 Xiangyang NTN-Yulon Drivetrain Co., Ltd.	US. \$13,600,000	60	(60)

Affiliated Companies Accounted for by the Equity Method

56 TUNG PEI INDUSTRIAL CO., LTD.	NT. \$1,257,232,620	27.35	
57 TAIWAY Industry CO.,LTD.	NT. \$160,000,000	36.25	
58 UNIDRIVE PTY LTD.	A. \$5,000,000	40	
59 Beijing NTN-Seohan Driveshaft Co., Ltd.	US. \$6,000,000	40	(6.67)
60 ASAHII FORGE OF AMERICA CORP.	US. \$7,100,000	28.2	(28.2)
61 Seohan-NTN Driveshaft USA CORP.	US. \$6,000,000	49	
62 Nanjing Puzhen NTN Railway Bearing Co.,Ltd.	US. \$6,600,000	40	(40)
63 Seohan-NTN Bearing CO.,LTD.	WON 71,200,000,000	49	
64 NTN-DONGPAI (Shanghai) Bearing Sales Corp.	US. \$1,460,000	25	(25)

1. Of the above consolidated subsidiaries, NTN USA CORP., NTN DRIVESHAFT, INC., NTN-BOWER CORP., NTN TRANSMISSIONS EUROPE, NTN NEI Manufacturing India Private LTD., NTN (CHINA) Investment Corp., Nanjing NTN Corp., Shanghai NTN Corp. and NTN-LYC (Luoyang) Bearing Corp. are specified subsidiaries.
2. Figures in curved brackets under "Holding as percentage" indicate the percentage of indirectly owned holdings, and are included in the total holding.

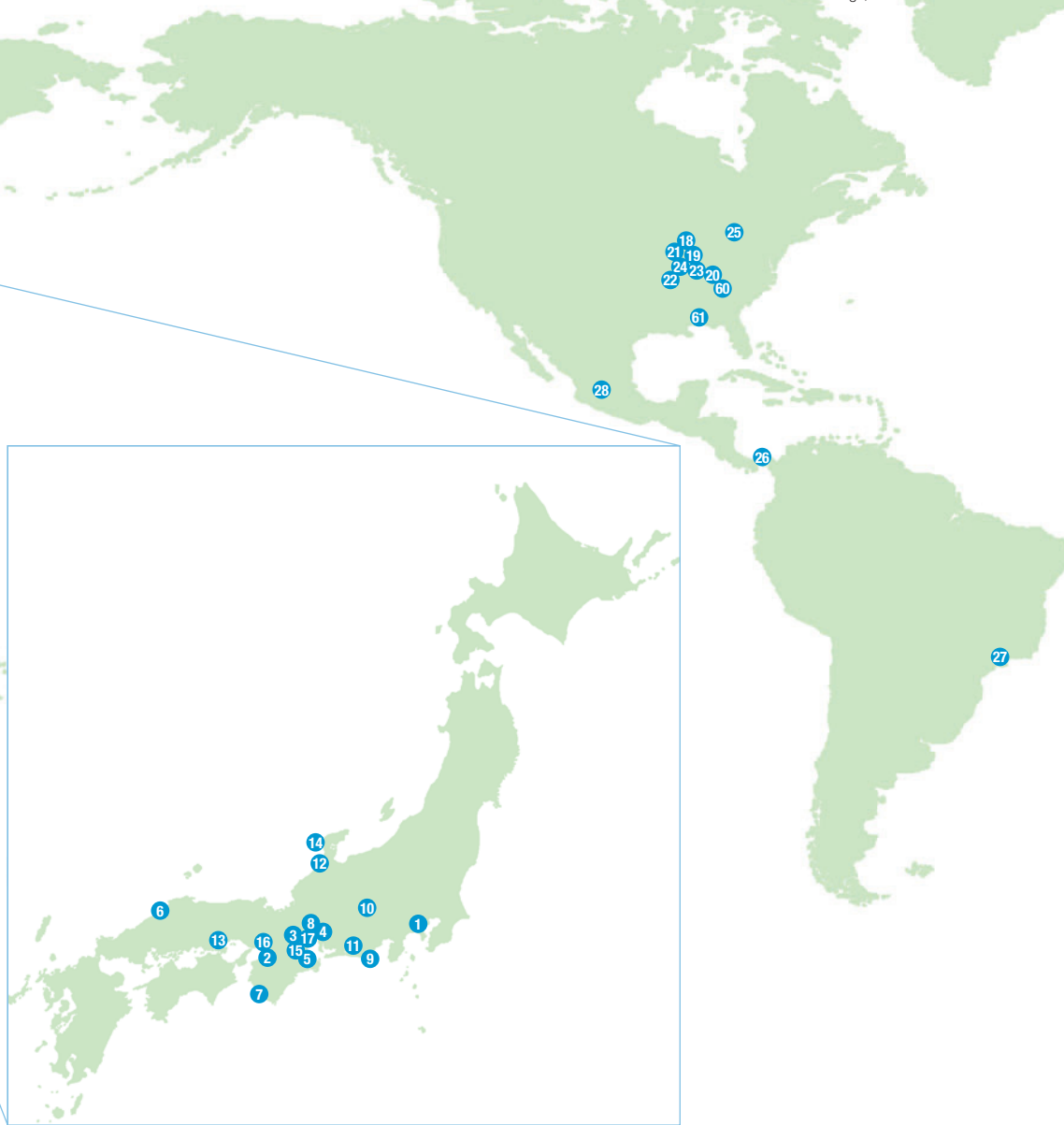

For New Technology Network

NTN®

NTN Corporation

3-17, 1-chome, Kyomachibori,
Nishi-ku, Osaka 550-0003, Japan
<http://www.ntn.co.jp>



This report was printed with an environment-friendly printing method using vegetable inks. Vegetable inks have excellent biodegradability, and printed matter printed with vegetable inks is easy to recycle.